

Netz- und Anlagenschutzrelais

RE - NA003-M64

Art. Nr.: 270010xG



BENUTZER HANDBUCH

für SW: 02.13.02g
02.14.02g

Änderungen und Irrtümer vorbehalten



**KLIMANEUTRALES
PRODUKT**
certified by Fokus Zukunft

Inhalt

1	Sicherheit und Symbole	7
1.1	Bestimmungsgemäße Verwendung.....	7
1.2	Sicherheitshinweise	7
1.3	Elektrofachkraft	8
2	Montage und Anschluss	8
2.1	Abmessungen und Bedienelemente.....	8
2.2	Vorsicherung der Versorgungsspannung	8
2.3	Klemmenbelegung.....	9
2.4	Montage auf Hutschiene gemäß EN 60715	9
2.5	Anschlussbild 1 (allgemein, ohne FRT-Maßnahmen)	10
2.6	Anschlussbild 2 (allgemein, mit FRT-Maßnahmen)	11
2.7	Anschlussbild 3 (CEI 0-21).....	12
2.8	Anschlussbild 4 (C10/11).....	13
3	Funktion	14
3.1	Features.....	14
3.2	Inbetriebnahme	14
3.3	Funktionsbeschreibung	14
3.4	Schutzfunktionen / Komparatoren	16
3.4.1	Spannungsüberwachung	16
3.4.2	Frequenzüberwachung	17
3.4.3	Phasensprungüberwachung.....	17
3.5	Inselnetzerkennung	18
3.5.1	Inselnetzerkennung mittels Spannungsmessung.....	18
3.5.2	Inselnetzerkennung mittels RoCoF.....	18
3.5.3	Inselnetzerkennung mittels Vektorsprung.....	18
3.6	Testfunktion	18
3.7	Digitale Eingänge	18
3.8	Ausgangsrelais R1, R2 und R3	19
3.9	Fehler (Error).....	20
3.9.1	Messwertfehler.....	20
3.9.2	Systemfehler.....	20
3.9.3	Fehlerspeicher (LOG).....	20
3.10	Neuheiten länderspezifische Parametersätze.....	21
3.10.1	VDE-AR-N 4105:2018.....	21
3.10.2	C10/11:2021	22
3.10.3	EN50549-1/2:2019 (Voreinstellungen Niederlande)	23
3.10.4	OPEN_SETUP	23
4	Bedienung und Inbetriebnahme	24
	Erste Inbetriebnahme.....	24

4.1	Menüführung	24
4.1.1	Ebene 0	24
4.1.2	Ebene 1	24
4.1.3	Ebene 2	25
4.1.4	Ebene 3	25
4.1.5	Ebene 4	25
4.1.6	Ebene 5	26
4.2	Menüstruktur	27
4.3	Plombierung.....	28
4.4	Fallbeispiele.....	28
4.4.1	Einsatz von Spannungswandlern in Mittelspannungsnetzen	28
4.4.2	FRT (Fault Ride Through) Fähigkeit von Stromerzeugungsanlagen:.....	29
4.4.3	Selbsthalteschaltung für Fernabschaltung mit manueller Freigabe	31
4.4.4	Anschluß eines Rundsteuerempfängers für Leistungsreduktion 0%.....	31
4.5	Versorgungskreis	32
4.6	Messkreis	32
4.7	Messbereiche	33
4.8	Digitale Eingänge	33
4.9	Ausgangskreis	33
4.10	Genauigkeit	33
4.11	Isolationsdaten	34
4.12	Umgebungsbedingungen.....	34
4.13	Elektrischer Anschluss	34
4.14	Plombier Draht	34
4.15	Schutzart	34
5	Settings der implementierten Parametersätze	35
5.1.1	Connection Modes	35
5.1.2	Einheiten	35
5.1.3	Funktionale Sicherheit.....	35
5.1.4	Operational Mode	35
5.1.5	Schwellen	35
5.1.6	Zeiten	36
5.1.7	Hilfskontakt.....	36
5.1.8	Ranges.....	36
6	Sicherheitskonzept	37
7	Glossar	39
8	Verfügbare Normen und Standards	40
9	Übersicht der implementierten Parametersätze	44
9.1	OVE TOR R25 NS SYNC (Typ A/B Niederspng. für synchrone Stromerzeugungsanlagen)	44
9.2	OVE TOR R25 NS ASYNC (Typ A/B Niederspng. für nicht syncr. Stromerzeugungsanlagen)	44
9.3	OVE TOR R25 MS SYNC (Typ A/B Mittelspng. für synchrone Stromerzeugungsanlagen)	44

9.4	OVE TOR R25 MS ASYNC (Typ A/B Mittelspng. für nicht synchr. Stromerzeugungsanlagen)	45
9.5	OOE TOR R25 NS SYNC (Typ A/B Niederspng. für synchrone Stromerzeugungsanlagen)	45
9.6	OOE TOR R25 NS ASYNC (Typ A/B Niederspng. für nicht synchr. Stromerzeugungsanlagen)	45
9.7	OOE TOR R25 MS SYNC (Typ A/B Mittelspng. für synchrone Stromerzeugungsanlagen)	46
9.8	OOE TOR R25 MS ASYNC (Typ A/B Mittelspng. für nicht synchr. Stromerzeugungsanlagen)	46
9.9	W TOR R25 NS SYNC (Typ A/B Niederspng. für synchrone Stromerzeugungsanlagen)	46
9.10	W TOR R25 NS ASYNC (Typ A/B Niederspng. für nicht synchr. Stromerzeugungsanlagen).....	47
9.11	W TOR R25 MS SYNC (Typ A/B Mittelspng. für synchrone Stromerzeugungsanlagen).....	47
9.12	W TOR R25 MS ASYNC (Typ A/B Mittelspng. für nicht synchr. Stromerzeugungsanlagen).....	47
9.13	TIROL TOR NS SYNC (Typ A/B Niederspng. für synchrone Stromerzeugungsanlagen)	48
9.14	TIROL TOR NS ASYNC (Typ A/B Niederspng. für nicht synchr. Stromerzeugungsanlagen)	48
9.15	TIROL TOR MS SYNC (Typ A/B Mittelspng. für synchrone Stromerzeugungsanlagen)	48
9.16	TIROL TOR MS ASYNC (Typ A/B Mittelspng. für nicht synchr. Stromerzeugungsanlagen)	48
9.17	VDE-AR-N 4105:2018-11 (Pn ≤ 50 kW).....	49
9.18	VDE-AR-N 4105:2018-11 (Pn > 50 kW).....	49
9.19	VDE-AR-N 4105:2018-11 (Umrichter)	49
9.20	VDE-AR-N 4110:2018-11 (geprüft nach TR3, Bewertungsbericht TR8)	50
9.21	CEI 0-21:2019	50
9.22	G99/1/3 LV:2018 (Niederspannung).....	50
9.23	G99/1/3 HV:2018 (Mittel/Hochspannung).....	51
9.24	G98/1/2:2018 (Niederspannung).....	51
9.25	C10-11:2021 LV-IP (Interface Protection / Niederspannung)	51
9.26	C10-11:2019 LV-ASS (Automatic Separation System / Niederspannung).....	52
9.27	C10-11:2021 HV-IP (Interface Protection / Hochspannung).....	52
9.28	C10-11:2019 HV-ASS (Automatic Separation System / Hochspannung).....	52
9.29	NA/EEA- CH 2014 Typ A <1MW (Niederspannung)	53
9.30	NA/EEA-NE7 - CH 2020 Typ A 800W bis 250kW (Niederspannung)	53
9.31	NA/EEA-NE7 - CH 2020 Typ B 250kW bis 36MW (Niederspannung)	53
9.32	EN 50549-1:2019 LV (Niederlande)	54
9.33	EN 50549-2:2019 HV (Niederlande).....	54
9.34	EN 50438:2013 (DK)	55
9.35	VDE 0126-1-1:2013 (ERDF-NOI-RES_13E Frankreich).....	55
9.36	AB AS 4777.2:2020	55
9.37	C AS 4777.2:2020	56
9.38	NZS 4777.2:2020	56
9.39	NRS 097-2-1:2017.....	57
9.40	OPEN SETUP.....	57
9.41	EN 50438:2013	58
9.42	E 8001/8101 (Vorgänger von OVE TOR R25)	58
9.43	VDE 0124-100:2013 (Vorgänger von VDE-AR-N 4105:2018-11).....	58
9.44	TR3 Rev23:2013 (Vorgänger von VDE-AR-N 4110:2018-11).....	58

9.45	AS/NZS 4777.2:2015 (Niederspannung).....	59
9.46	G59/3/3:2015 LV (Niederspannung – Vorgänger von G99/1/3 LV:2018)	59
9.47	G59/3/3:2015 MV (Mittelspannung Vorgänger von G99/1/3 HV:2018).....	59
9.48	G83/2:2012 (Niederspannung Vorgänger von G98/1/2:2018)	60
9.49	C10-11:2012 LV (Niederspannung Vorgänger von C10-11:2019).....	60
9.50	C10-11:2012 MV (Mittelspannung Vorgänger von C10-11:2019).....	60
9.51	C10-11:2019 LV-IP (Interface Protection / Niederspannung Vorgänger von C10-11:2021)	61
9.52	C10-11:2019 HV-IP (Interface Protection / Hochspannung Vorgänger von C10-11:2021)).....	61
10	ANHANG (Parameter der implementierten Standards im Detail).....	62
10.1	ÖVE TOR R25 NS SYNC [ID 802] Typ A/B low voltage synchr. generators	62
10.2	ÖVE TOR R25 NS ASYNC [ID 803] Typ A/B low voltage asynchr. generators	65
10.3	ÖVE TOR R25 MS SYNC [ID 852] Typ A/B medium voltage synchr. generators.....	68
10.4	ÖVE TOR R25 MS ASYNC [ID 853] Typ A/B medium voltage asynchr. generators	70
10.5	Oberösterreich OOE TOR R25 NS SYNC [ID 822] Typ A/B low voltage synchr. generators	72
10.6	Oberösterreich OOE TOR R25 NS ASYNC [ID 823] Typ A/B low voltage asynchr. generators	74
10.7	Oberösterreich OOE TOR R25 MS SYNC [ID 872] Typ A/B medium voltage synchr. generators.....	76
10.8	Oberösterreich OOE TOR R25 MS ASYNC [ID 873] Typ A/B med. voltage asynchr. generators	79
10.9	Wien TOR R25 NS SYNC [ID 832] Typ A/B low voltage synchr. generators.....	82
10.10	Wien TOR R25 NS ASYNC [ID 833] Typ A/B low voltage asynchr. generators.....	85
10.11	Wien TOR R25 MS SYNC [ID 882] Typ A/B medium voltage synchr. generators.....	88
10.12	Wien TOR R25 MS ASYNC [ID 883] Typ A/B medium voltage asynchr. generators	90
10.13	TIROL TOR NS SYNC [ID 812] Typ A/B low voltage synchr. generators	92
10.14	TIROL TOR NS ASYNC [ID 813] Typ A/B low voltage asynchr. generators.....	95
10.15	TIROL TOR MS SYNC [ID 862] Typ A/B medium voltage synchr. generators	98
10.16	TIROL TOR MS ASYNC [ID 863] Typ A/B medium voltage asynchr. generators	100
10.17	VDE-AR-N 4105:2018 ≤50kW [ID 311]	102
10.18	VDE-AR-N 4105:2018 >50kW [ID 312]	105
10.19	VDE-AR-N 4105:2018 Umr [ID 313]	108
10.20	VDE-AR-N 4110:2018 TR3-25 [ID 706].....	111
10.21	CEI 0-21:2019 [ID 102]	114
10.22	G99/1/3:2018 LV [ID 410]	117
10.23	G99/1/3:2018 HV [ID 460]	119
10.24	G98/1/2:2018 [ID 510]	121
10.25	C10-11:2021 LV-IP [ID 603] Interface Protection low voltage.....	123
10.26	C10-11:2019 LV-ASS [ID 602] Automatic Separation System / Low Voltage	127
10.27	C10-11:2021 HV-IP [ID 653] Interface Protection / High Voltage.....	129
10.28	C10-11:2019 HV-ASS [ID 652] Automatic Separation System / High Voltage.....	132
10.29	NA/EEA- CH 2014 [ID 1200] Low Voltage Type A up to 1MW.....	134
10.30	NA/EEA-NE7 - CH 2020 [ID 1220] Low Voltage Type A > 800W to ≤ 250kW	137
10.31	NA/EEA-NE7 - CH 2020 [ID 1221] Low Voltage Type B > 250kW to ≤ 36MW	140
10.32	EN50549-1:2019 LV Netherlands [ID 901]	143

10.33	EN50549-2:2019 HV Netherlands [ID 926]	147
10.34	EN50438:2013 DK [ID 950]	151
10.35	VDE 0126-1-1:2013 [ID 200]	154
10.36	AB AS 4777.2:2020 [ID 1110].....	156
10.37	C AS 4777.2:2020 [ID 1120].....	158
10.38	NZS 4777.2:2020 [ID 1130].....	161
10.39	NRS 097-2-1:2017 [ID 1000]	164
10.40	OPEN SETUP [ID 9006]	167
10.41	EN50438:2013 [ID 900].....	171
10.42	OVE E8001/8101:2014 [ID 801] renewed standard.....	173
10.43	VDE 0124-100:2013 [ID 300] renewed standard	176
10.44	TR3 Rev23:2013 [ID 700] renewed standard	178
10.45	AS/NZS 4777.2:2015 [ID 1102] renewed standard.....	180
10.46	G59/3/3:2015 LV [ID 405] renewed standard	182
10.47	G59/3/3:2015 MV [ID 455] renewed standard	185
10.48	G83/2:2012 [ID 500] renewed standard	188
10.49	C10-11:2013 LV [ID 600] renewed standard.....	191
10.50	C10-11:2013 MV [ID 650] renewed standard	193
10.51	C10-11:2019 LV-IP [ID 601] Interface Protection low voltage	195
10.52	C10-11:2019 HV-IP [ID 651] Interface Protection / High Voltage	198

1 Sicherheit und Symbole

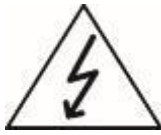

**Vorsicht! Niemals bei angelegter Spannung arbeiten.
Es besteht Lebensgefahr! Das Gerät bei erkennbarer Beschädigung auf keinen Fall verwenden! Verwendung nur durch geschultes Fachpersonal!**



**Fachprodukt!
Dieses Produkt setzt besondere Fachkenntnisse bei der Installation voraus!**



Dieses Gerät unterliegt der Elektro- und Elektronik-Altgeräteverordnung (WEEE) und darf nicht im normalen Hausmüll entsorgt werden. Das Gerät besteht aus Werkstoffen, die von darauf spezialisierten Recycling-Betrieben wiederverwertet werden können. Entsorgen Sie es entsprechend den nationalen gesetzlichen Bestimmungen.

1.1 Bestimmungsgemäße Verwendung

Der TELE NA003 dient dem Netz- und Anlagenschutz (NA-Schutz) bei einspeisenden Blockheizkraftwerken, Windkraft-, Wasserkraft- und Photovoltaikanlagen.

Im Falle eines Stromausfalls oder einer Störung im Netz des Energieversorgungsunternehmens müssen private Kleinkraftwerke sofort vom öffentlichen Netz getrennt werden, um die ungewollte Einspeisung zu verhindern. Ohne sofortige Netztrennung würde einerseits das Wartungspersonal gefährdet, andererseits könnten Verbraucher unzulässigen Spannungen und Frequenzen ausgesetzt werden.

Für den Fall, dass Netzbetreiber von den Standards abweichende Grenzwerte fordern, ist es teilweise möglich, Grenzwerte außerhalb des normativ definierten Bereiches einzustellen.

Außerhalb dieses Bereiches ist das Gerät nicht mehr normkonform und die entsprechenden Zertifikate verlieren ihre Gültigkeit. Dieser Status wird am Display durch die Kennung „ncnf“ dargestellt. Einstellungen außerhalb dieses Bereiches liegen somit in der Verantwortung des Betreibers und/oder der Abnahmestelle der Anlage.

1.2 Sicherheitshinweise

Dieses Gerät wurde nach anerkannten sicherheitstechnischen Regeln gebaut und geprüft. Dennoch kann bei unsachgemäßer Verwendung Gefahr für Mensch und Gerät entstehen.

Benutzen Sie dieses Gerät nur für die bestimmungsgemäße Verwendung, im sicherheitstechnisch einwandfreien Zustand und unter Beachtung der für den Einsatzort geltenden Regeln und Vorschriften zur Unfallverhütung.

- Beseitigen Sie sofort alle Störungen, die die Sicherheit beeinträchtigen können.
- Nehmen Sie keine unzulässigen Änderungen vor und verwenden Sie ausschließlich Ersatzteile und Zusatzeinrichtungen, welche vom Hersteller des Gerätes verkauft oder ausdrücklich empfohlen werden.
- Bei offensichtlicher Beschädigung darf das Gerät nicht mehr verwendet werden.
- Die länderspezifischen Normen und Richtlinien sind zu beachten.
- Der NA003 kann nach der Inbetriebnahme mittels Passwortschutz oder Plombierung gegen unbefugte Änderungen geschützt werden. Sollte dies in der jeweils länderspezifischen Norm bzw. Richtlinie gefordert sein, muss einer der obengenannten Schutzmechanismen angewandt werden.

1.3 Elektrofachkraft

Eine Elektrofachkraft kann Gefahren durch die Elektrizität selbstständig erkennen und vermeiden. Voraussetzungen dafür sind:

- Kenntnisse der Elektrotechnik
- Erfahrungen mit elektrotechnischer Arbeit
- Kenntnisse und Arbeitserfahrung an der jeweiligen Anlage oder ähnlichen Anlagen (Anlagenart)
- Kenntnisse der Gefährdungen und Gegenmaßnahmen
- Die Fähigkeit zu erkennen, ob die Sicherheit bei der Arbeitsdurchführung gegeben ist

Die Elektrofachkraft ist speziell für das Arbeitsumfeld, in dem sie tätig ist, ausgebildet und kennt relevante Normen und Bestimmungen. Es gelten die Vorschriften des jeweiligen Landes.

2 Montage und Anschluss

2.1 Abmessungen und Bedienelemente

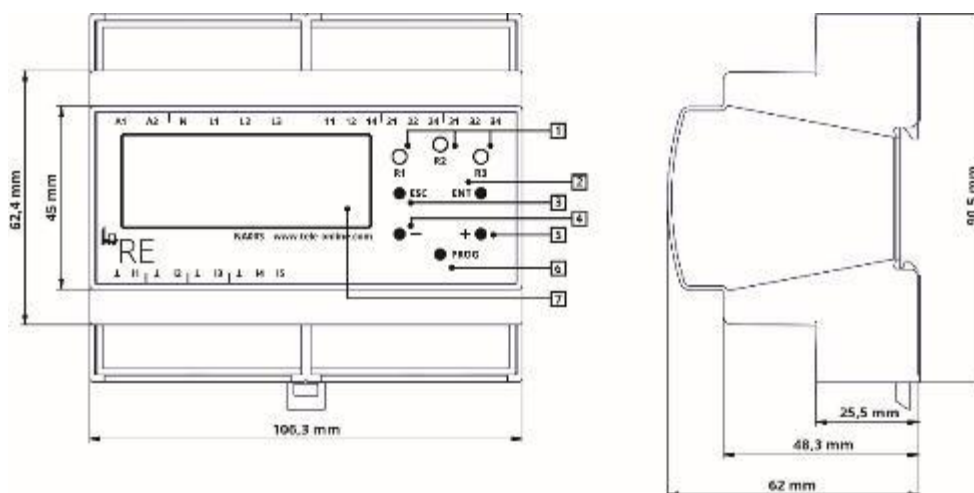

Legende	Beschriftung	Typ	Funktion
1	R1, R2, R3	LED (gelb)	Statusanzeige Ausgangsrelais
2	ENT	Taster	ENTER, Eingabe, nächste Ebene
3	ESC	Taster	ESCAPE, Retour, Ebene zurück, Test/Reset
4	-	Taster	Parametereinstellung, Anzeigenwechsel
5	+	Taster	Parametereinstellung, Anzeigenwechsel
6	PROG	Taster (plombierbar)	PROGRAMM, Programmieren
7		LCD-Display 4x20 Character	Anzeige

2.2 Vorsicherung der Versorgungsspannung

Die Versorgungs- und Messspannungen aller Systemkomponenten sind mit Vorsicherungen abzusichern. Die Vorsicherungen sind gemäß dem verwendeten Leiterquerschnitt zu dimensionieren. Wir empfehlen die Ausgangsrelais bei Gefahr von Kurzschluss mit einer Sicherung 5A flink abzusichern!

2.3 Klemmenbelegung

A1, A2	Versorgungskreis	DC: 24V AC: 110 - 230V A1: L (+) A2: N (-)
L1, L2, L3, N	Messkreis	U _n : 3x400V AC
11, 12, 14	Ausgangsrelais Kanal A (Wechsler) Statusanzeige durch gelbe LED R1	Kontaktausgang (potentialfrei) 11: Wurzel 12: Öffner 14: Schließer
21, 22, 24	Ausgangsrelais Kanal B (Wechsler) Statusanzeige durch gelbe LED R2	Kontaktausgang (potentialfrei) 21: Wurzel 22: Öffner (n.c. / normally closed) 24: Schließer (n.o. / normally open)
31, 32, 34	Ausgangsrelais D (Wechsler) Statusanzeige durch gelbe LED R3	Kontaktausgang (potentialfrei) 31: Wurzel 32: Öffner (n.c. / normally closed) 34: Schließer (n.o. / normally open)
I1, ⊥	Digitaler Eingang 1 (Rückmeldekontakt Schütz A)	Kontakteingang (24V/5mA) Eingang aktiv: wenn I1 und ⊥ verbunden (konfigurierbar)
I2, ⊥	Digitaler Eingang 2 (Rückmeldekontakt Schütz B)	Kontakteingang (24V/5mA) Eingang aktiv: wenn I2 und ⊥ verbunden (konfigurierbar) Entfällt bei allen länderspezifischen Normen bei denen keine funktionale Sicherheit gefordert ist!
I3, ⊥	Digitaler Eingang 3 (Fernabschaltung)	Kontakteingang (24V/5mA) Eingang aktiv: I3 und ⊥ verbunden (konfigurierbar)
I4, I5, ⊥	Digitale Eingänge 4 und 5 (Umschaltung auf narrower frequency window)	Für CEI 0-21 und C10/11 Kontakteingang (24V/5mA) Eingang aktiv: wenn I4 bzw. I5 und ⊥ verbunden

2.4 Montage auf Hutschiene gemäß EN 60715

Rasten Sie den rückseitigen Montageclip des Geräts auf der Hutschiene so ein, dass ein sicherer und fester Sitz gewährleistet ist.

2.5 Anschlussbild 1 (allgemein, ohne FRT-Maßnahmen)

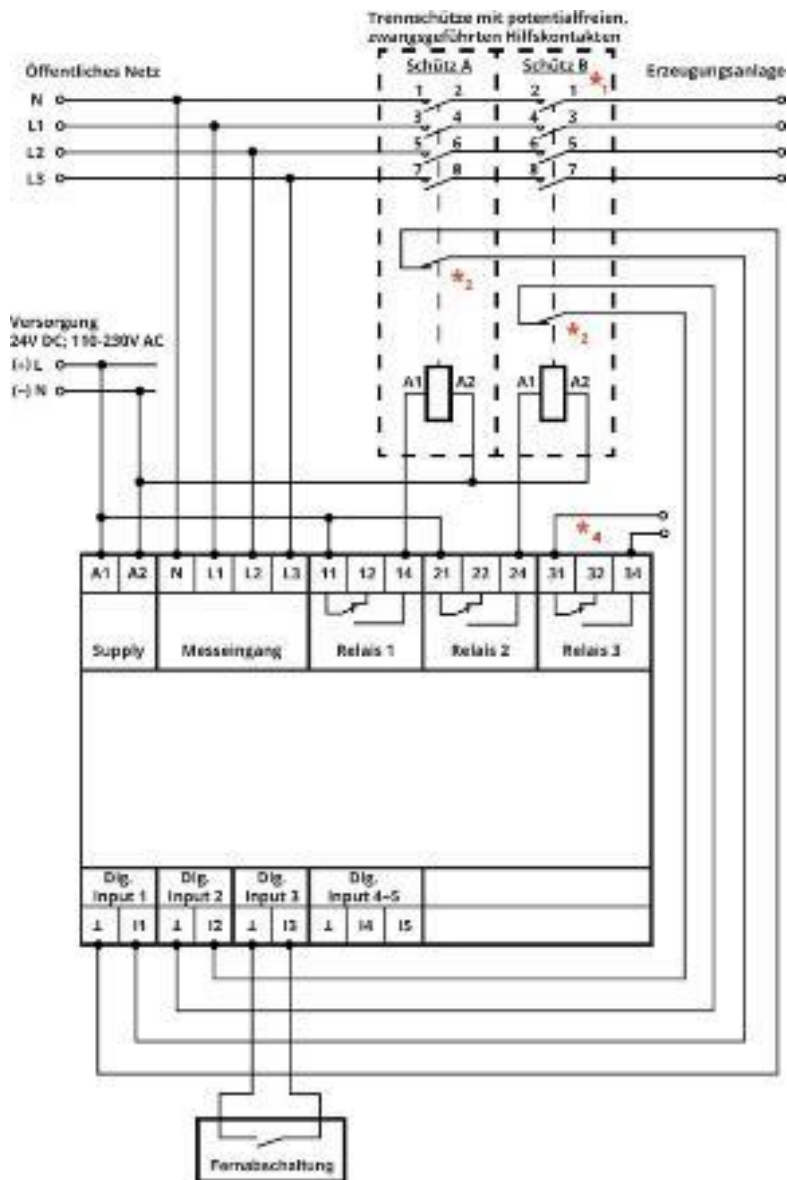

Anzuwenden für:

Aktuelle Standards

OVE TOR R25 NS/MS A/SYNC,
 OOE TOR R25 NS/MS A/SYNC
 W TOR R25 NS/MS A/SYNC
 TIROL TOR NS/MS A/SYNC
 VDE-AR-N 4105:2018-11 (Pn ≤ 50 kW) *1, *4, *5
 VDE-AR-N 4105:2018-11 (Pn > 50 kW) *1, *4, *5
 VDE-AR-N 4105:2018-11 (Umrichter) *4, *5
 VDE-AR-N 4110:2018-11 *1
 G99-1-3 LV:2018 *1
 G99-1-3 HV:2018 *1
 G98-1-2:2018 *1
 C10-11:2019 LV-ASS *1, *4
 C10-11:2019 HV-ASS *1, *4
 EN50549-1:2019 LV
 EN50549-2:2019 HV
 EN50438:2013 DK *3
 VDE 0126-1-1:2013
 AS/NZS 4777.2:2020
 NRS 097-2-1:2017
 OPEN SETUP *3

Rezertifizierte Standards

EN50438:2013
 OVE E 8001-4-712 / E 8101-4-712
 VDE 0124-100:2013
 TR3 Rev23:2013 *1
 AS/NZS 4777.2:2015
 G59/3/3:2015 LV *1
 G59/3/3:2015 MV *1
 G83/2:2012 *1
 C10-11:2012 LV *1
 C10-11:2012 MV *1
 C10-11:2019 LV-IP *1, *4
 C10-11:2019 HV-IP *1, *4

- *1 ... Schütz B entfällt bei allen länderspezifischen Normen bei denen keine funktionale Sicherheit gefordert ist!
- *2 ... Hilfskontakt als Öffner, Schließer oder „nicht überwacht“ konfigurierbar.
- *3 ... 1- oder 2-kanaliger Anschluss möglich und konfigurierbar.
- *4 ... Auswertung, Kontaktfehler für Eigenerzeugungsanlagen nur für VDE-AR-N 4105:2018-11 und C10-11:2019
- *5 ... VDE-AR-N 4105:2018-11 mit gepufferten Trennschützen für ein FRT (fault ride through) Verhalten

2.6 Anschlussbild 2 (allgemein, mit FRT-Maßnahmen)

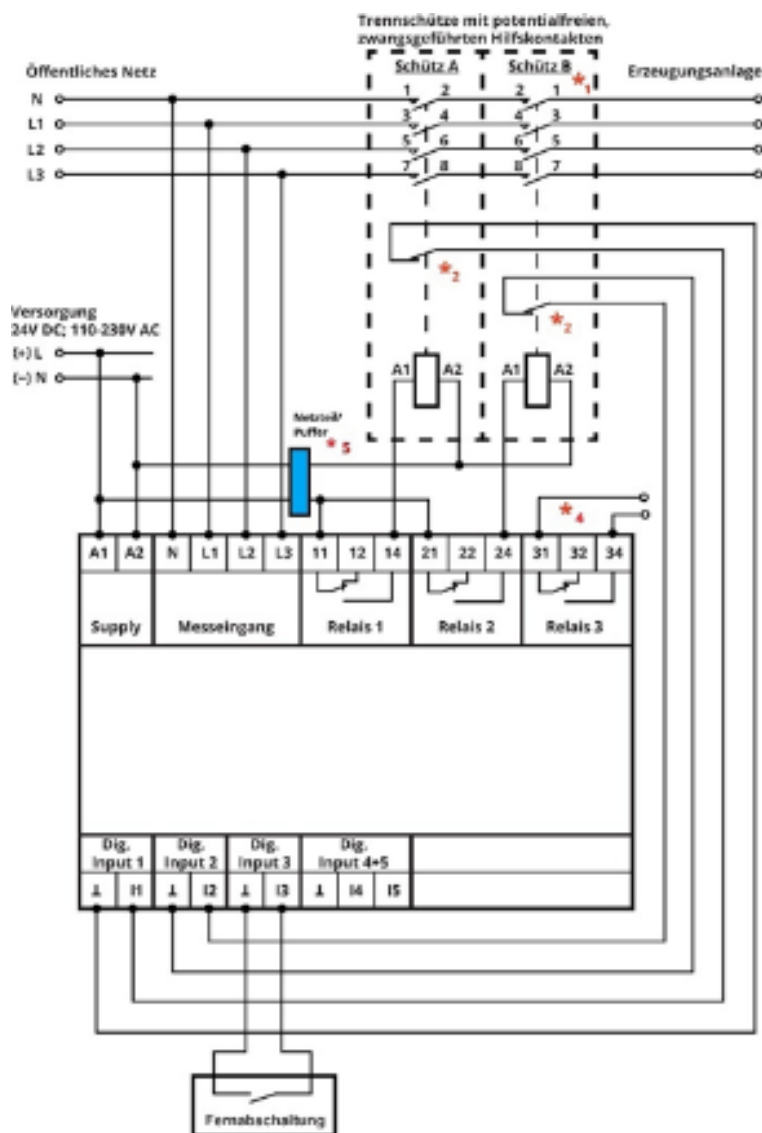

Anzuwenden für:

Standards wie in 2.5 beschrieben

*5 Verhalten von Trennschützen bei Unterspannung (FRT/fault ride through)

Netzteil/Puffer. Trennschütze und wenn vorhanden Koppelrelais müssen bei Unterspannung für 3s / 0,3s gepuffert werden (FRT).

Auch in Niederspannungsnetze einspeisende Anlagen müssen das Netz unterstützen. Deshalb darf der Trennschütz bei einem Spannungseinbruch auf einen Wert knapp über $U_{<<}$ ($0,45 U_n$) bzw. 0,3s bei Spannungsunterbrechung wegen Unterspannung nicht abfallen, sondern erst wenn ihn der NA003 nach 3s ($U_{<}$) bzw. 0,3s ($U_{<<}$) abschaltet (Netzteil/Puffer nötig).

Bei Verwendung von 2 Trennschützen müssen beide für 3s versorgt werden. Der NA003 verfügt über ein internes Breitbandnetzgerät und braucht daher keine gepufferte Steuerspannung.

ACHTUNG bei Signalfolge:

Puffer - NA003 - Trennschütz. Das Abschaltsignal darf NICHT verzögert werden!

- *1 ... Schütz B entfällt bei allen länderspezifischen Normen bei denen keine funktionale Sicherheit gefordert ist!
- *2 ... Hilfskontakt als Öffner, Schließer oder „nicht überwacht“ konfigurierbar.
- *3 ... 1- oder 2-kanaliger Anschluss möglich und konfigurierbar.
- *4 ... Auswertung, Kontaktfehler für Eigenerzeugungsanlagen nur für VDE-AR-N 4105:2018-11 und C10-11:2019
- *5 ... Mit gepufferten Trennschützen, um ein FRT (fault ride through) Verhalten zu gewährleisten

2.7 Anschlussbild 3 (CEI 0-21)

Anzuwenden für:

CEI 0-21:2019

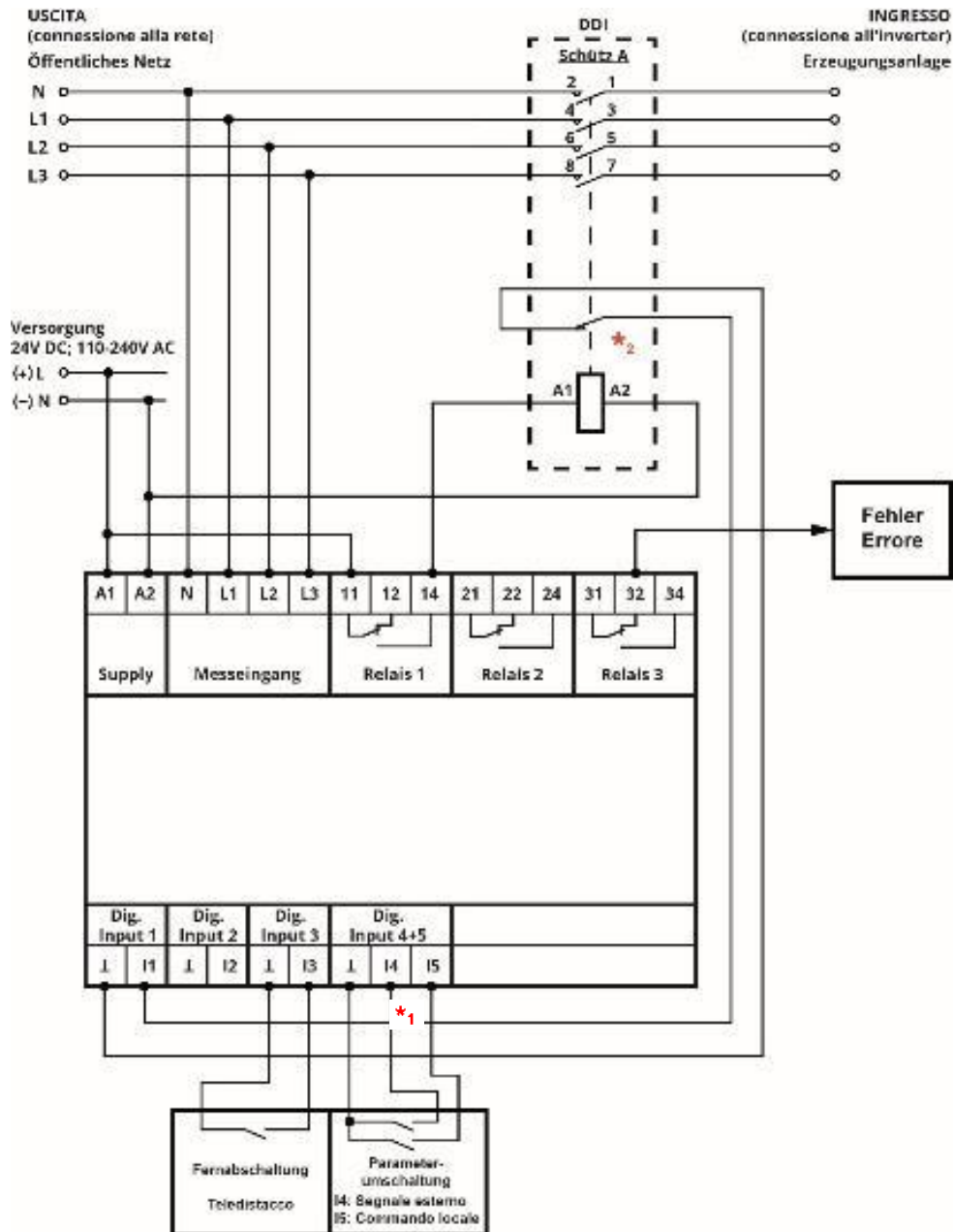

*₁ Parameterumschaltung:

definitive mode (Operational mode 0):

I4 inaktiv / Kontakt geöffnet:

Overfrequency 1, Underfrequency 1

I4 aktiv / Kontakt geschlossen:

Overfrequency 2, Underfrequency 2

transitory mode (Operational mode 1):

I5 aktiv / Kontakt geschlossen:

Overfrequency 2, Underfrequency 2

I5 inaktiv / Kontakt geöffnet:

Overfrequency 3, Underfrequency 3

*₂ Hilfskontakt als Öffner, Schließer oder „nicht überwacht“ konfigurierbar

2.8 Anschlussbild 4 (C10/11)

Anzuwenden für:

C10/11:2021 LV

C10/11:2021 HV

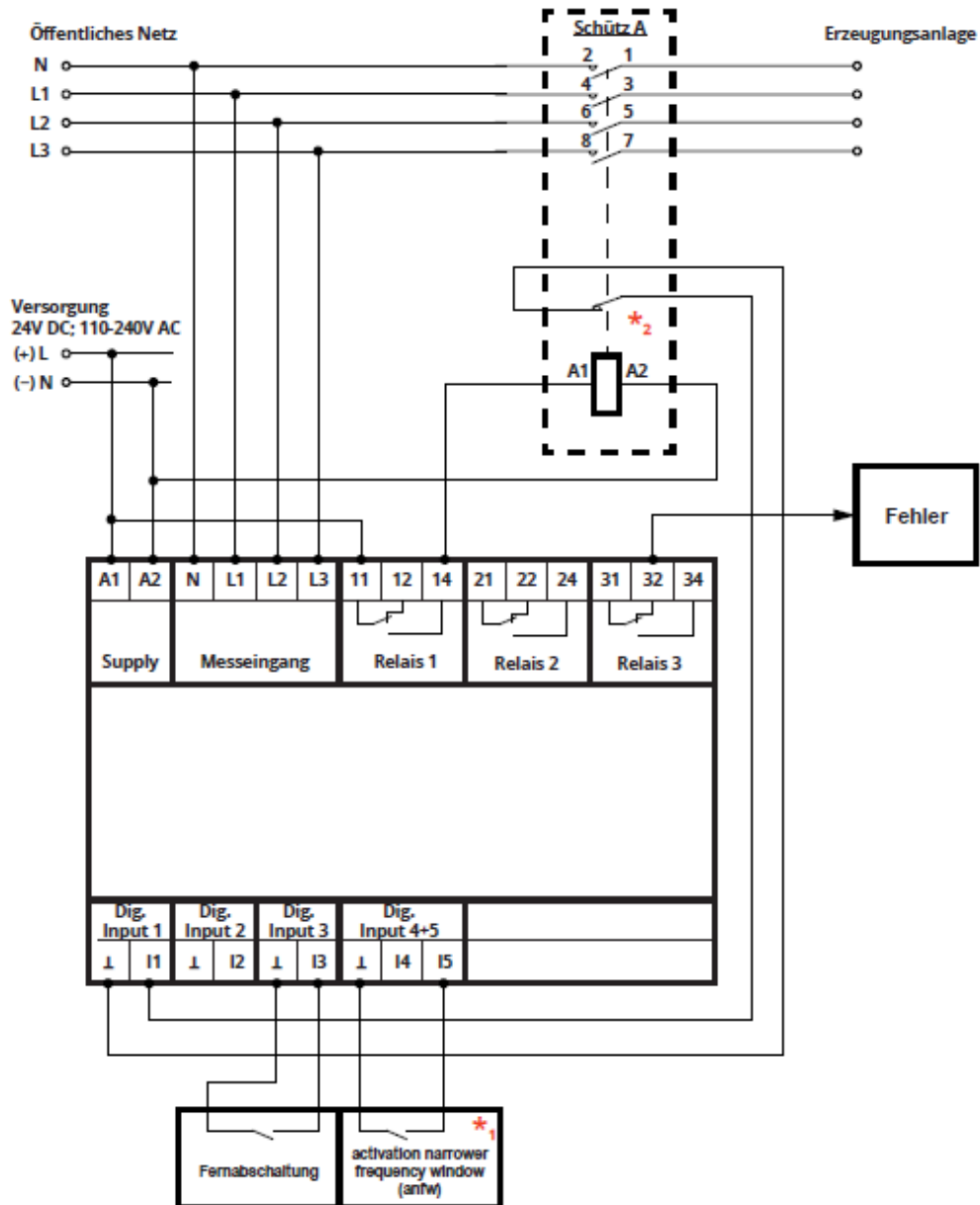

*₁ Parameterumschaltung:

15 inaktiv / Kontakt geöffnet:

Overfrequency 1, Underfrequency 1

15 aktiv / Kontakt geschlossen:

Overfrequency 2, Underfrequency 2 (narrower frequency window)
(based on local voltage criteria / local setting)

*₂ Hilfskontakt als Öffner, Schließer oder „nicht überwacht“ konfigurierbar

3 Funktion

3.1 Features

- Einfache Inbetriebnahme durch vordefinierte Setups für länderspezifische Normen und Richtlinien mit in weiten Grenzen einstellbaren Parametern
- Weiter Nennspannungs- und Nennfrequenzbereich, Einstellbare Nennspannung
- Schutzfunktionen $U \ll$, $U <$, $U >$, $U \gg$, U_{10min} , $f <$, $f >$ ($f \ll$, $f \gg$)
- Zusätzliches „Open Setup“ für freie, praktisch unbeschränkte Parametrierbarkeit im Feld
- Einfehlersicherheit
- Zyklischer Selbsttest
- Überwachung der angeschlossenen Kuppelschalter
- Fernabschaltung
- Inselnetzerkennung (RoCoF, PShift, Außenleiterspannung)
- Testfunktion mit Ermittlung der Abschaltzeit der angeschlossenen Trennschütze
- Überwachung von 1- und 3-phasigen Netzen für Nieder- und Mittelspannungsnetze
- Fehlerspeicher mit Zeitstempel (50 Einträge)
- Passwortschutz und Plombierbarkeit
- Zufällige Abschaltsschwellen und Zuschaltzeiten für nichtregelbare Energieerzeuger (z.B. BHKW)
- Erfassung der symmetrischen Komponente Zero Sequence im 3-Phasennetz (U_{zero})
- Umschaltung auf unterschiedliche Frequenzbänder (narrower frequency window)
- FRT-Fähigkeit (fault ride through)
- Konfigurationsservice und Einzelprüfprotokolle

3.2 Inbetriebnahme

Nach dem Anlegen der Versorgungsspannung an A1 und A2 erscheint am Display für 5 sek die Startanzeige. Das Gerät wird ohne eingestellten Parametersatz ausgeliefert. Bei der Erstinbetriebnahme geht das Gerät in die Parametersatzauswahl (Ebene 5 - Menüpunkt 5.001). Hier muss mittels +/- der entsprechende länderspezifische Parametersatz/Norm ausgewählt und mit ENTER bestätigt werden. Nähere Informationen dazu finden sie unter 4.2 Menüstruktur.

3.3 Funktionsbeschreibung

Je nach ausgewähltem länderspezifischen Parametersatz führt das Gerät mehrere Überwachungsfunktionen (Schutzfunktionen) gleichzeitig durch.

Soweit nicht anders angegeben beträgt die Nennspannung 230V/400V und die Nennfrequenz 50Hz (Kontrolle Menüpunkt 1.010)

1.010	df1t	60
U1	230.0V	f 50.00Hz
U2	230.0V	
U3	230.0V	

Beim Über- oder Unterschreiten eines Grenzwertes schalten R1 und R2 nach einer für jeden Grenzwert eigens definierten Ansprechverzögerung ab. Beim Selbsttest und bei Aktivierung der Fernabschaltung schalten R1 und R2 sofort ab. Erst wenn alle überwachten Größen innerhalb der zulässigen Grenzen liegen und die Fernabschaltung deaktiviert wurde, schalten R1 und R2 nach einer definierten Einschaltzeit wieder zu.

R1 und R2 sorgen mit den angeschlossenen Trennschützen (A und B) für die geforderte Netztrennung (Erzeugungsanlage – öffentliches Netz) bei Ansprechen einer Schutzfunktion.

Durch die Rückmeldekontakte der Trennschütze, die mit den digitalen Eingängen des NA003-M64 verbunden sind, werden die Schalthandlungen der Trennschütze ebenfalls überwacht, was die Anlagensicherheit weiter erhöht.

Achten Sie darauf, dass die Rückmeldekontakte der Trennschütze A/B korrekt angeschlossen sind. Menüpunkt 1.040 gibt Auskunft über den Zustand der Schütze A und B (DI1 und DI2). Möglicherweise müssen die Rückmeldekontakte umparametriert werden unter Menüpunkt 3.099 (n.c. versus n.o.). Eine weitere Fehlerquelle bilden die Massen der digitalen Eingänge I1 und I2, die intern nicht miteinander verbunden sind und deshalb immer angeschlossen werden müssen.

R1(2) dunkel bedeutet R1(2) sind OFF (unbetätigt):

1.040	df1t	60			
Toff ---ms					
DI1	DI2	DI3	DI4	DI5	
1	1	0	0	0	

Die digitalen Eingänge DI1(2) signalisieren mit „1“ einen geschlossenen Rückmeldekontakt der Trennschütze. Wenn bei Parameter 3.099 n.c. (normally closed) ausgewählt ist, wurde korrekt verdrahtet.

Signalisieren die digitalen Eingänge DI1(2) jedoch „0“ einen offenen Rückmeldekontakt der Trennschütze wie in folgendem Bild,

1.040	df1t	60			
Toff ---ms					
DI1	DI2	DI3	DI4	DI5	
0	0	0	0	0	

müsste Parameter 3.099 auf n.o. (normally open) umgestellt werden, oder die Verdrahtung zwischen den Trennschützen A(B) und den digitalen Eingängen wurde nicht korrekt durchgeführt.

Tabellarische Ansicht Einstellung Parameter 3.099:

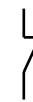
Art des Trennschütz-Hilfskontaktes			Parameter 3.099 (Einstellwert)
Kontakttyp	Kontaktbezeichnung	Symbol	
Schließer (n.o.)	13/14, 23/24, 33/34, ...		n.o.
Öffner (n.c.)	11/12, 21/22, 31/32, ...		n.c.

3.4 Schutzfunktionen / Komparatoren

Je nach gewähltem Parametersatz sind bestimmte Schutzfunktionen / Komparatoren editierbar.

3.4.1 Spannungsüberwachung

Außenleiter 59.S1 59.S2	Überspannung 1 Überspannung 2	Alle 3 Außenleiterspannungen werden entsprechend den eingestellten Überspannungsschaltsschwellen überwacht. Bei Überschreiten der Schaltschwelle schalten R1 und R2 nach der eingestellten Ansprechverzögerung t_{off} auf OFF. Diese Überwachung ist im 2-phasigen (L+N) sowie 4-phasigen (L1,L2,L3+N) Connection Mode deaktiviert!
Außenleiter 27.S1 27.S2	Unterspannung 1 Unterspannung 2	Alle 3 Außenleiterspannungen werden entsprechend den eingestellten Unterspannungsschaltsschwellen überwacht. Bei Unterschreiten der Schaltschwelle schalten R1 und R2 nach der eingestellten Ansprechverzögerung t_{off} auf OFF. Diese Überwachung ist im 2-phasigen (L+N) sowie 4-phasigen (L1, L2, L3+N) Connection Mode deaktiviert!
Stern 59.S1 59.S2	Überspannung 1 Überspannung 2	Alle 3 Sternspannungen werden entsprechend den eingestellten Überspannungsschaltsschwellen überwacht. Bei Überschreiten der Schaltschwelle schalten R1 und R2 nach der eingestellten Ansprechverzögerung t_{off} auf OFF. Ausnahme: Im 2-phasigen (L+N) Connection Mode erfolgt eine Spannungsmessung nur zwischen L1 und N! Diese Überwachung ist im 3-phasigen (L1, L2, L3) Connection Mode deaktiviert!
Stern 27.S1 27.S2	Unterspannung 1 Unterspannung 2	Alle 3 Sternspannungen werden entsprechend den eingestellten Unterspannungsschaltsschwellen überwacht. Bei Unterschreiten der Schaltschwelle schalten R1 und R2 nach der eingestellten Ansprechverzögerung t_{off} auf OFF. Ausnahme: Im 2-phasigen (L+N) Connection Mode erfolgt nur eine Überspannungsmessung zwischen L1 und N! Diese Überwachung ist 3-phasigen (L1, L2, L3) Connection Mode deaktiviert!
Mittelwert 59-AV	Überspannung	Die gebildeten 10-Minuten Mittelwerte werden entsprechend den eingestellten Schaltschwellen für den langsamen Spannungssteigerungsschutz überwacht. Bei Überschreiten der Schaltschwelle schalten R1 und R2 nach der eingestellten Ansprechverzögerung t_{off} auf OFF. Im 2-phasigen Connection Mode: L-N Im 3-phasigen Connection Mode: L1-L2-L3 Im 4-phasigen Connection Mode: L1-N; L2-N; L3-N
U (Zero Sequence) Uzero Stern Außenleiter 59V0	Überspannung	Alle 3 Sternspannungen werden mit Betrag und Phasenlage addiert, die resultierende Spannung betragsmäßig zum Nulleiter ermittelt und in Folge gedrittelt. Bei Überschreiten der Schaltschwelle schalten R1 und R2 nach der eingestellten Ansprechverzögerung t_{off} auf OFF. Die Zero Sequence ist nur im 4 phasigen (LN +LL) Connection Mode aktiviert!
U (resultierend) Ures Stern Außenleiter	Überspannung	Aktivierung des narrower frequency window bei Überschreiten der Schaltschwelle von 3 x Zero Sequence nach der eingestellten Ansprechverzögerung t_{off} .

U (activation narrower frequency window) Uanfw Stern	Unterspannung	Alle 3 Sternspannungen werden entsprechend den eingestellten Unterspannungsschaltsschwellen überwacht. Bei Unterschreiten der Schaltschwelle kommt es nach der eingestellten Ansprechverzögerung t_{off} zur Aktivierung des narrower frequency window .
---	---------------	---

3.4.2 Frequenzüberwachung

Überfrequenz 1 Überfrequenz 2 Überfrequenz 3 Überfrequenz 4 81O.S1, 81O.S2, 81O.S3, 81O.S4	Die Frequenz der 3 Sternspannungen werden entsprechend den eingestellten Überfrequenzschaltsschwellen überwacht. Bei Überschreiten der Schaltschwelle schalten R1 und R2 nach der eingestellten Ansprechverzögerung t_{off} auf OFF. Ausnahme: im 2-wire mode wird nur U L1-N überwacht.
Unterfrequenz 1 Unterfrequenz 2 Unterfrequenz 3 Unterfrequenz 4 81U.S1, 81U.S2, 81U.S3, 81U.S4	Die Frequenzen der 3 Sternspannungen werden entsprechend den eingestellten Unterfrequenzschaltsschwellen überwacht. Bei Unterschreiten der Schaltschwelle schalten R1 und R2 nach der eingestellten Ansprechverzögerung t_{off} auf OFF Ausnahme: im 2-wire mode wird nur U L1-N überwacht.
Überfrequenz Zufall	Die Frequenz der 3 Sternspannungen werden entsprechend den eingestellten Überfrequenzschwellen (zufällige Max Frequenz) überwacht. Bei Überschreiten der Schaltschwelle schalten R1 und R2 nach der eingestellten Ansprechverzögerung t_{off} auf OFF Ausnahme: im 2-wire mode wird nur U L1-N überwacht.
Frequenzüberwachung Unterspannung LL Frequenzüberwachung Unterspannung LN	Je nach Modus (2, 3, 4 wire) führt ein Unterschreiten der eingestellten Schwelle zur Deaktivierung der Frequenzüberwachung.
RoCoF 81R	Die Frequenzänderungsraten der 3 Sternspannungen werden entsprechend den eingestellten Parametern überwacht. Bei Überschreiten der Schaltschwelle schalten R1 und R2 nach der eingestellten Ansprechverzögerung t_{off} auf OFF Ausnahme: im 2-wire mode wird nur U L1-N überwacht.

3.4.3 Phasensprungüberwachung

Phase Shift 78	Das Phasensprungverhalten der 3 Sternspannungen wird entsprechend den eingestellten Parametern überwacht. Bei Überschreiten der Schaltschwelle schalten R1 und R2 nach der eingestellten Ansprechverzögerung t_{off} auf OFF Ausnahme: im 2-wire mode wird nur U L1-N überwacht.
-----------------------	--

3.5 Inselnetzerkennung

Dabei handelt es sich um ein lokal abgegrenztes Stromnetz, das nur aus einem oder wenigen Stromerzeugern besteht, nur mehr ein kleines Gebiet versorgt und keinen Anschluss mehr zu anderen Stromnetzen hat.

3.5.1 Inselnetzerkennung mittels Spannungsmessung

Bei diesem Verfahren wird mit Hilfe der 3-phasigen Spannungsüberwachung (Außenleiter) ein Inselnetz erkannt.

3.5.2 Inselnetzerkennung mittels RoCoF

Bei diesem Verfahren wird ein Inselnetz mit Hilfe der Frequenzänderungsrate (Rate of change of frequency) erkannt. Die Messung beruht auf Frequenzmessung und spricht bei einer über mehrere Perioden andauernden Frequenzänderung an. Der df/dt -Grenzwert wird in mHz/s angegeben und eingestellt.

3.5.3 Inselnetzerkennung mittels Vektorsprung

Bei diesem Verfahren wird durch Zeitmessung der Halbwellen und dem Vergleich mit vorhergehenden Messungen ein Phasen- bzw. Vektorsprung erkannt. Ein Vektorsprung kann durch einen plötzlichen Lastwechsel oder Kurzschlüsse im übergeordneten Netz auftreten. Der Grenzwert wird in Grad angegeben und eingestellt.

3.6 Testfunktion

Die Testfunktion kann auf 2 Arten ausgelöst werden:

- Betätigen der ESC Taste in jeder beliebigen Anzeige der Menüebene 1
- Betätigen der ENT Taste im Fenster 1.050

Die beiden Ausgangsrelais R1 und R2 werden bei Aktivierung der Testfunktion abgeschaltet und die Zuschaltzeit beginnt abzulaufen.

Wie bei jeder Abschaltung wird auch bei der Testfunktion die Abschaltzeit der angeschlossenen Trennschütze/Kuppelschalter gemessen: Die jeweils letzte Abschaltzeit kann in Anzeige 1.040 abgelesen werden (Toff)

3.7 Digitale Eingänge

Die aktuellen Zustände der digitalen Eingänge können mit dem Menüpunkt 1.040 festgestellt werden.

Die digitalen Eingänge 1 und 2 (jeweils mit \perp) dienen als Rückmeldekontakte der beiden Trennschütze A und B. Sie werden über den Hilfskontakt des Trennschützes angesteuert. Hierbei kann der Hilfskontakt als Öffner oder Schließer angeschlossen und der digitale Eingang im Gerät entsprechend konfiguriert werden.

Der digitale Eingang 3 (I3 und \perp) dient der Fernabschaltung. Bei Konfiguration .114 (I3 STOP) mit n.o. (normally open) werden R1 und R2 durch Brücken von I3 mit \perp abgeschaltet. Verwendet man n.c. (normally closed), muß für einen normalen Betrieb (R1 und R2 eingeschaltet) I3 mit \perp gebrückt sein. Durch ein Öffnen I3 von \perp werden R1 und R2 abgeschaltet und damit auch die angeschlossenen Trennschütze A und B (Öffentliches Netz von Erzeugereinheit getrennt). Wird für .114 dis. (disabled) gewählt, kann gar keine Fernabschaltung durchgeführt werden.

Die beiden digitalen Eingänge 4 und 5 dienen der Parameterumschaltung für den italienischen Parametersatz CEI 0-21:2019.

Der digitale Eingang 5 dient der Aktivierung des narrower frequency window für die belgischen und europäischen Parametersätze C10/11:2021 und EN50549-1/2:2019

Die unterschiedlichen \perp bei den digitalen Eingängen sind intern nicht miteinander verbunden, müssen bei Verwendung also einzeln angeschlossen werden.

3.8 Ausgangsrelais R1, R2 und R3

Die beiden Ausgangsrelais R1 und R2 steuern die Trennschütze/Kuppelschalter an. Ist das vom NA003-M64 gemessene öffentliche Netz ok, darf die Erzeugungseinheit einspeisen. R1 und R2 schalten dazu auf ON (LED R1 und LED R2 leuchten), die angeschlossenen Trennschütze an 11-14 (21-24) werden betätigt und verbinden die Erzeugungseinheit mit dem öffentlichen Netz.

Bewegen sich gemessene Stern/Außenleiterspannungen, die Netzfrequenz, (oder RoCoF, Pshift, Uzero) außerhalb der ihnen zugeordneten Grenzwerte, wird eine Schutzfunktion verletzt. In diesem Fall schalten R1 und R2 auf OFF, welche wiederum die Trennschütze durch Öffnen 11-14 (21-24) zum Abfallen bringen und somit die Erzeugungseinheit vom öffentlichen Netz trennen.

Das Ausgangsrelais R3 wird länderspezifisch behandelt, Damit können Fehlerzustände (Verletzungen der Schutzfunktion, falsch konfigurierte/verdrahtete Rückmeldekontakte) ausgewertet werden. Je nachdem, für welchen Fehlerfall R3 konfiguriert ist, schaltet es im Fehlerfall auf ON (LED R3 leuchtet) wenn z.B. ein Spannungsfehler besteht, oder die Rückmeldekontakte nicht/falsch geschlossen sind).

3.9 Fehler (Error)

Die Anzeige aktueller Fehler befindet sich in Ebene „1.060 Error“, die Anzeige des Fehlerspeichers befindet sich in Ebene 2. Es wird zwischen Messwert- und Systemfehlern unterschieden:

3.9.1 Messwertfehler

```
1.060 Error
M: UΔ UY Ū f Δf ΔΦ C
S: T0123456789ABCDEF
   ENT ->
```

Hier wird nur der aktuell anliegende Fehler angezeigt!

Fehlerarten:

- UΔ Fehler Außenleiterspannung (Unter- oder Überspannung)
- UY Fehler Sternspannung (Unter- oder Überspannung, Zero Sequence)
- Ū Fehler 10 Minuten Spannungsmittelwert
- f Fehler Frequenz (Unter- oder Überfrequenz)
- Δf Fehler Frequenzrampe (RoCoF)
- ΔΦ Fehler Phasensprung (PShift)
- C Fehler Rückmeldekontakt – Schütz fälschlich geschlossen
- c Fehler Rückmeldekontakt – Schütz fälschlich offen

3.9.2 Systemfehler

```
1.060 Error
M: UΔ UY Ū f Δf ΔΦ C
S: T0123456789ABCDEF
   ENT ->
```

Fehlerarten:

- T Fernabschaltung aktiv
- 0-9, A-F Tritt einer dieser Fehler permanent auf, kontaktieren Sie bitte unseren technischen Support.

Im Auslieferungszustand befinden sich im Fehlerspeicher Systemfehlereinträge. Diese entstehen werksseitig bei der Endprüfung des Gerätes, bei der diese Fehler bewusst herbeigeführt wurden. Da der Fehlerspeicher nicht löschar sein darf, stellen diese Einträge keinen Gerätefehler dar und können ignoriert werden.

3.9.3 Fehlerspeicher (LOG)

Die Anzeige des Fehlerspeichers für max. 50 LOGs befindet sich in Ebene 2.

Im Fehlerspeicher wird sowohl das Auftreten als auch das Wegfallen jedes Fehlers mit einem Zeitstempel gespeichert. Ein Eintrag ohne Fehlercodes ist daher kein Fehlverhalten.

```
2.0nn Error
M: UΔ UY Ū f Δf ΔΦ C
S: T0123456789ABCDEF
t: 9999d 15h 03m 01s
```

nn ... Nummer des Eintrages im Fehlerspeicher

t ... Zeitstempel: Zeitdauer seit Auftritt des Fehlers in Tagen/Stunden/Minuten/Sekunden

3.10 Neuheiten länderspezifische Parametersätze

3.10.1 VDE-AR-N 4105:2018

Bei den 3 Parametersätzen der VDE-AR-N 4105 (ID:311,312,313) gilt folgendes für die Inbetriebnahme:

Bei der Inbetriebnahme ist darauf zu achten, dass nur mehr ein Kuppelschalter (an R1) angewendet werden soll. VDE-AR-N 4105 für Umrichter bildet hier eine Ausnahme- hier müssen weiterhin 2 Kuppelschalter (an R1 und R2) zur Anwendung kommen.

Im Weiteren müssen die/der Rückmeldekontakt/e an den dafür vorgesehenen digitalen Eingängen I1(2) und \perp angeschlossen sein. Letztendlich wird unter Parameter 3.099 festgelegt, ob es sich bei den/m Rückmeldekontakt/en um normally closed (n.c.) oder normally open (n.o.) handelt.

Am Display erscheint ein Error C (Contact), insofern dies nicht berücksichtigt wurde. NA003 darf für die VDE-AR-N 4105 während Error C die Ausgangsrelais R1 und R2 nicht einschalten, solange die Rückmeldekontakte nicht korrekt angeschlossen und parametrier sind.

Contact Error-Reset:

Liegt U_N 3x400V AC ordnungsgemäß an, kann erst durch Drücken der Taste Esc (Ebene 1.010) oder Ent (Ebene 1.050) ein Reset durchgeführt werden. Der Contact Error wird dadurch gelöscht und die Ausgangsrelais R1 und R2 ziehen nach Ablauf der Einschaltzeit an.

Ein bestehender Contact Error kann zusätzlich über R3 an die Erzeugungsanlage gemeldet werden.

In diesem Zusammenhang möchten wir auf Kapitel 3.7 Testfunktion hinweisen (Ermittlung der Auslösezeit des Kuppelschalters).

Neuer Parameter T ConDelOn:

Durch Synchronisierereinrichtungen oder Leistungsschalter ist es erlaubt, dass nach der Freigabe durch das NA-Schutzrelais der/die Kuppelschütz/e erst verzögert eingeschaltet werden. Daher erfolgt auch die Rückmeldung vom Rückmeldekontakt verzögert. Die zulässige Ansprechverzögerung wird mit dem **Parameter 3.110.**

T ConDelOn definiert. In der Grundeinstellung ist diese Zeit mit **100ms** parametrier und kann bis auf maximal 300.000ms (5min) gestellt werden. Die Konformität ist bis 10.000ms gewährleistet.

Kriterien für den eingesetzten Kuppelschalter:

Bei den eingestellten 100ms Auslösezeit für die unterschiedlichen Schutzfunktionen ergibt sich bei den **deutschen Parametersätzen** eine maximale Auslösezeit des NA003-M64 von 119ms. Um die Gesamtauslösezeit von ≤ 200 ms (NA003-M64 + Kuppelschalter) zu gewährleisten, **muss der eingesetzte Kuppelschalter innerhalb von 81ms auslösen** können.

Passwortschutz:

Die Geräte sind bezüglich der VDE-AR-N 4105 bei Auslieferung mit einem fixen Passwortschutz versehen. Das Passwort lautet „4105“. Der Inbetriebnehmer ist aufgefordert, das Passwort aus Sicherheitsgründen unverzüglich zu ändern (siehe 5.2.5)

3.10.2 C10/11:2021

Schutzfunktion Zero Sequence:

Die Erfassung der Zero Sequence (U_{zero}) im Dreiphasensystem bildet eine weitere Ergänzung der Schutzfunktionen. Durch die Zero Sequence können beispielsweise Kurzschlüsse im übergeordneten Mittelspannungsnetz erfasst werden. Dazu werden die drei im Normalfall um 120° verschobenen Sternspannungen L1, L2 und L3 sowohl unter Betrachtung der Betrages als auch der Phasenlage zueinander addiert, die so entstehende betragsmäßige Spannungsdifferenz (ohne Winkel) zum Neutralleiter ermittelt und durch drei dividiert.

Wenn alle drei Sternspannungen den gleichen Betrag aufweisen und exakt 120° zueinander verschoben sind, beträgt die Zero Sequence 0VAC.

In der derzeit gültigen Fassung der C10/11 beträgt der Grenzwert für die Zero Sequence 20% U_n (46VAC). Bei Überschreitung dieses Grenzwertes $>1,5s$ schalten R1 und R2 ab und schalten nach Ablauf der Ton delay erst wieder ein, wenn die Zero Sequence 15% U_n (34,5VAC) unterschreitet. Die zugehörigen Parameter findet man im Parametersatz ID:603 von 3.115 bis 3.118 (siehe Anhang).

Für die Ermittlung der Zero Sequence wird der Connection Mode 4-wire (LN+LL) benötigt. Dieser ist im Parametersatz ID 603 für C10-11:2021 LV-IP standardmäßig aktiviert und darf bei vorgeschriebener Schutzfunktion Zero Sequence durch den lokalen Netzbetreiber auch nicht abgeändert werden. Im Parametersatz ID 653 für C10-11:2021 HV-IP muß die Ermittlung der Zero Sequence mit dem lokalen Netzbetreiber individuell abgesprochen und entsprechend eingestellt werden.

Für eine fehlerfreie Erfassung der Zero Sequence darf keiner der 3 Winkel (Φ_1 , Φ_2 oder Φ_3) zwischen L1, L2 und L3 $>180^\circ$ überschreiten. Des Weiteren muß die Drehrichtung der 3 Phasen L1->L2->L3 unbedingt eingehalten werden. Dazu müssen L1, L2 und L3 des öffentlichen Netzes parallel zu den Anschlüssen L1, L2 und L3 des NA003-M64 angeschlossen werden. Für die Erfassung der Zero Sequence ist der Neutralleiter verpflichtend anzuschließen (auch aufgrund Connection Mode 4-wire (LN+LL)).

Aktivierung des narrower frequency window:

Diese basiert auf 2 Kriterien der lokal vorherrschenden Spannungen bei Inselbildung. Bei Ansprechen wird zusätzlich zur normalen Frequenzüberwachung $\leq 47,5Hz$ und $\geq 51,5Hz$ ($<100ms$) ein engeres Frequenzfenster $<49,7Hz$ und $>50,3Hz$ (500ms) überwacht und bildet so eine weitere Schutzfunktion für eine Abschaltung von R1 und R2 zur Netztrennung.

1. Kriterium: Aktivierung des narrower frequency window bei Überschreitung $U_{res-anfw} > 5\% U_n$ ($U_{res-anfw} = 3 * U_{zero}$). Zugehörige Parameter für Deaktivierung beispielsweise beginnend von 3.119 bis 3.122.
Bei diesem Kriterium ist zu beachten, dass es bereits bei kleinsten betraglichen Änderungen einer der 3 Sternspannungen $<218,5VAC$ (bei $U_n = 230VAC$) oder einer Winkeländerung einer der drei Sternspannungen um $>2,87^\circ$ zur Aktivierung des narrower frequency windows kommt.
2. Kriterium: Aktivierung des narrower frequency window bei Unterschreitung bei einer der drei Sternspannungen $<85\%$. Dieses Kriterium ersetzt die Messung der mit- und gegenläufigen symmetrischen Komponenten des 3-Phasensystems.
Zugehörige Parameter für beispielsweise Deaktivierung Beginnend mit 3.123 bis 3.126.

Eine weitere Möglichkeit zur Aktivierung des narrower frequency windows ist das Brücken des digitalen Einganges I5 mit \perp , um hier weitere Messmöglichkeiten anschließen zu können, wie in der EN50549-1:2019 + AC:2019 empfohlen (siehe Anschlussbild 4).

Wichtig!

Die Einstellungen zur Aktivierung des narrower frequency window (3.062 bis 3.069 und 3.119 bis 3.126) müssen unbedingt mit dem lokalen Netzbetreiber abgesprochen und dokumentiert werden.

3.10.3 EN50549-1/2:2019 (Voreinstellungen Niederlande)

Für die europäische EN50549-1/2 gelten betreffend der Aktivierung des narrower frequency window die gleichen Voraussetzungen wie unter Kapitel 3.10.2 Die entsprechenden Parameter (3.062 bis 3.069 und 3.119 bis 3.126) sind allerdings deaktiviert und müssen nach Absprache mit dem lokalen Netzbetreiber parametrisiert werden. Im Weiteren kann in den Parametersätzen der EN50549-1/2 ebenfalls die Schutzfunktion Zero Sequence aktiviert werden wie in 3.10.2 erwähnt.

Die Voreinstellungen im Parametersatz sind für die standardmäßigen Schutzfunktionen der Niederlande ausgelegt.

3.10.4 OPEN_SETUP

Innerhalb des Parametersets 9006_OPEN_SETUP können ab sofort Spannungsschwellwerte für die Deaktivierung aller 3 möglichen Frequenzüberwachungen aktiviert werden. Aktivierung/Deaktivierung erfolgt mit Parameter .046 für LL-Messungen und Parameter .050 für LN-Messungen. Mit .047 (für LL) bzw. mit .051 (für LN) können im Weiteren die Spannungsschwellen für die Deaktivierung der Frequenzüberwachungen eingestellt werden. In den meisten Ländern bewegen sich diese um die 20%Un. Die Hysterese für die abermalige Zuschaltung ist automatisch mit 1% definiert. Beim OPEN_SETUP können auch die Zero Sequence als die Activation of narrower frequency band aktiviert werden.

4 Bedienung und Inbetriebnahme

Erste Inbetriebnahme

Das Gerät wird ohne eingestellten Parametersatz ausgeliefert. Bei der Erstinbetriebnahme geht das Gerät in die Parametersatzauswahl (Ebene 5 - Menüpunkt 5.001). Hier muss mittels +/- der entsprechende Parametersatz/Norm ausgewählt und mit ENTER bestätigt werden.

Weitere Informationen finden sie in der Menüstruktur.

4.1 Menüführung

Die Anzeigeeinheit besteht aus einem 4 zeiligen Text - Display mit je 20 Zeichen pro Zeile. Die Anzeige hat 5 Ebenen. Mittels + und - kann durch die verschiedenen Anzeigen der Ebenen navigiert werden.

4.1.1 Ebene 0

Startanzeige (Anzeige für 5 Sekunden beim Power Up)

Hier werden Basisinformationen wie die SW-Version und die Geräte-ID angezeigt. Diese Anzeige erscheint nach dem Einschalten und bleibt für 5s sichtbar. Danach springt die Anzeige auf das erste Fenster in Ebene1.

4.1.2 Ebene 1

Messwerte (Anzeige 1.010-1.032)

Anzeige der aktuellen Messwerte.

Außerdem wird hier angezeigt, ob das Parameterset der Default Konfiguration entspricht (dflt - default = Grund- oder Werkseinstellung), innerhalb der normativ zulässigen Grenzwerte editiert wurde (edit - edited = bearbeitet) oder außerhalb der normativ zulässigen Grenzwerte eingestellt ist (ncnf - non conform = nicht mit der ausgewählten Norm bzw. dem ausgewählten Standard konform).

Gegebenenfalls Anzeige Zeitablauf „reconnection timer“ (Zuschaltzeit) in Sekunden.

Navigation +/- . Von diesen Anzeigen gelangt man mittels ENT in Ebene 3

Digitale Inputs und Abschaltzeit (Anzeige 1.040)

Anzeige der aktuellen Zustände der digitalen Eingänge, sowie der letzten Abschaltzeit (Toff) der angeschlossenen Schütze (für zweikanalige Systeme der jeweils größere Wert).

Test/Reset (Anzeige 1.050)

Durch Betätigen der ENT-Taste wird ein Relaisreset ausgelöst. Dabei schalten die Relais A und B ab und der „reconnection-timer“ (Zuschaltzeit) beginnt abzulaufen.

Im Weiteren kann mit der Test/Reset-Funktion ein Reset-Ereignis durchgeführt werden, dass die Relais 1/2 nach einem Contact-Error (C) wieder zuschalten lässt (Notwendig für die drei Parametersätze der VDE-AR-N 4105). Das Test/Reset-Ereignis lässt sich auch durch Drücken der Taste ESC in Ebene 1 durchführen.

Error (Anzeige 1.060)

Anzeige aktueller Fehler:

M	Messwertfehler
S	Systemfehler

Navigation +/- . Durch Betätigen der ENT-Taste gelangt man in Ebene 2.

4.1.3 Ebene 2

Fehlerspeicher

Hier werden die letzten Fehler mit Zeitstempel (Zeit seit dem Auftreten) angezeigt. Die Zeit wird nur gezählt, wenn das Gerät versorgt ist. Es werden sowohl positive als auch negative Fehlerflanken gespeichert und angezeigt.

Navigation +/- . Von dieser Anzeige gelangt man mittels ESC in Ebene 1.

4.1.4 Ebene 3

Parameteranzeige

Hier werden für den jeweiligen Parametersatz die sichtbar geschalteten Parameter angezeigt.

Navigation +/- . Von dieser Anzeige gelangt man mittels ESC in Ebene 1.

Mittels PROG (plombierbar) gelangt man in den Editiermodus des gewählten Parameters.

Ist das Passwort „0000“ wird die Passwortabfrage übersprungen und man gelangt direkt in den Editiermodus in Ebene 5.

Wurde innerhalb der letzten 60 Sekunden ein gültiges Passwort eingegeben, so wird die Passwortabfrage übersprungen und man gelangt direkt in Ebene 5.

Wurde ein Passwort ungleich „0000“ festgelegt, so gelangt man zur Passwordeingabe in Ebene 4.

4.1.5 Ebene 4

Passwordeingabe

Mit +/- kann die jeweils aktive Stelle des Passwortes inkrementiert / dekrementiert (0..9) werden.

Mit ENT wird auf die jeweils nächste Stelle der Passwordeingabe gesprungen.

Nach Drücken von ENT bei der 4. Stelle wird das eingegebene Passwort überprüft.

Mit ESC wird auf die jeweils vorhergehende Stelle der Passwordeingabe gesprungen.

Nach Drücken von ESC bei der 1. Stelle des Passwortes wird in Ebene 3 zurückgesprungen.

Sollten Sie das eingestellte Passwort vergessen haben kontaktieren Sie bitte unter Bekanntgabe der Geräte-ID unseren technischen Support. Sie erhalten ein nur für Ihr Gerät gültiges Masterpasswort.

4.1.6 Ebene 5

Parametereditierung

In dieser Ebene kann der zuvor in Ebene 3 ausgewählte Parameter mit +/- geändert werden. Bestätigt wird mit ENT - Mit ESC wird die Änderung verworfen. In beiden Fällen springt die Anzeige auf den entsprechenden Parameter in Ebene 3.

Außerdem wird hier angezeigt, ob der Wert des gerade bearbeiteten Parameters der Defaultkonfiguration entspricht (dflt - default = Grund- oder Werkseinstellung), innerhalb der normativ zulässigen Grenzwerte editiert wurde (edit - edited = bearbeitet) oder außerhalb der normativ zulässigen Grenzwerte eingestellt ist (ncnf - non conform = nicht mit der ausgewählten Norm bzw. dem ausgewählten Standard konform).

Neben Schwellen, Zeiten und Modi sind auch die 4 Stellen des Passwortes je 1 Parameter.

Auch der aktuelle Standard ist ein Parameter. D.h. durch Ändern dieses Parameters wird der neue ausgewählte Standard aktiviert. Sämtliche bisherigen Änderungen werden dabei verworfen.

Wird der bereits eingestellte Standard ausgewählt, wird der Standard auf Werkseinstellungen (default) zurückgesetzt.

4.2 Menüstruktur

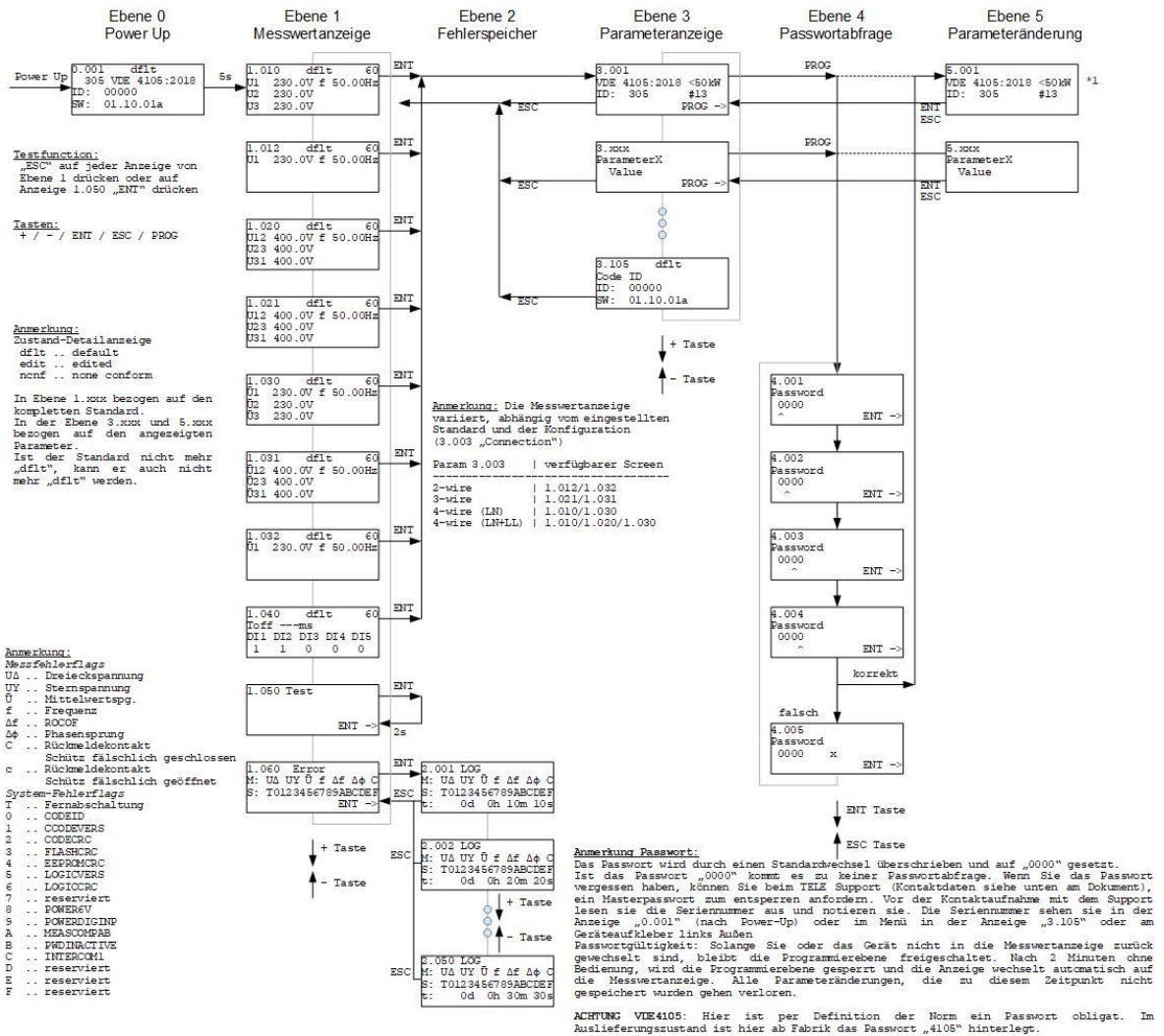

4.3 Plombierung

Das Gerät ist nach der Inbetriebnahme mittels einstellbaren Passworts gegen unbefugte Änderungen der schutzrelevanten Einstellparameter zu sichern! Wird der Passwortschutz nicht genutzt oder fordert es die länderspezifische Norm oder der Standard, so ist das Gerät zu plombieren!

4.4 Fallbeispiele

4.4.1 Einsatz von Spannungswandlern in Mittelspannungsnetzen

Am Beispiel Österreich wird bei Mittelspanng. zwischen zwei grundlegenden Spngs.niveaus unterschieden: 21kV und [31,7kV für Sonderfälle Z.B. Windparks]. Außenleiter (Phase-Phase-Spannung).

Zum Einsatz kommt ein 200:1 Spannungswandler bei $U_c=21kV$:

1. Wahl des Parametersatzes **852** (OVE/OOE TOR R25 MS SYNC) für synchrone bzw. **853** (OVE/OOE TOR R25 NS ASYNC) für nicht synchrone Erzeugungsanlagen (Umrichter).
2. Parameter .005 (Einstellung der Nominalspannung ULN/LL nom) auf **60.4/105.0V**.
Rechnerisch ergibt sich der Wert aus $21kV / 200 = 105V$ (die 60.4V stehen für die Sternspannungen, die bei Mittelspannungsanwendungen nicht relevant sind). Die Einstellmöglichkeiten sind wie mit **60.4/105.0V** beschrieben möglich.

Zum Einsatz kommt ein 200:1 Spannungswandler bei $U_c=31,7kV$ (z.B. Windpark):

1. Wahl des Parametersatzes **852** (OVE/OOE TOR R25 MS SYNC) für synchrone bzw. **853** (OVE/OOE TOR R25 NS ASYNC) für nicht synchrone Erzeugungsanlagen (Umrichter).
2. Parameter .005 (Einstellung der Nominalspannung ULN/LL nom) auf **91.0/158.1V**.
Rechnerisch ergibt sich der Wert aus $31,7kV / 200 = 158,5V$ (die 91.0V stehen für die Sternspannungen, die bei Mittelspannungsanwendungen nicht relevant sind). Die Einstellmöglichkeiten sind wie mit **91/158,1V** beschrieben möglich.

Zum Einsatz kommt ein 300:1 Spannungswandler bei $U_c=31,7kV$ (z.B. Windpark):

1. Wahl des Parametersatzes **852** (OVE/OOE TOR R25 MS SYNC) für synchrone bzw. **853** (OVE/OOE TOR R25 NS ASYNC) für nicht synchrone Erzeugungsanlagen (Umrichter).
2. Parameter .005 (Einstellung der Nominalspannung ULN/LL nom) auf **60.4/105.0V**.
Rechnerisch ergibt sich der Wert aus $31,7kV / 300 = 105,6V$ (die 60,4V stehen für die Sternspannungen, die bei Mittelspannungsanwendungen nicht relevant sind). Die Einstellmöglichkeiten sind wie mit **60.4/105.0V** beschrieben möglich.

In jedem Fall gilt: Alle Schutzfunktionen $U_{>>}$, $U_{>}$, $U_{<<}$, $U_{<}$ stellen sich automatisch auf die neu eingestellten Spannungsniveaus ein, d.h. hier brauchen nur Änderungen durchgeführt zu werden, wenn diese den Vorgaben des Netzbetreibers nicht entsprechen.

Änderung der Schutzfunktion $U_{>}$ und $U_{>>}$ nach Vorgaben des Netzbetreibers:

Im Auslieferungszustand (default) betragen diese Schwellen für $U_{>off}$ $1,06 \times U_c$ (106%) und für $U_{>>off}$ $1,1 \times U_c$ (110%). Sollte der Netzbetreiber hier Einstellungen für $U_{>off}$ von beispielsweise $1,04 \times U_c$ (104%) und $U_{>>off}$ von $1,15 \times U_c$ (115%) verlangen, müssen sowohl Parameter .011 als auch .027 dementsprechend verstellt werden. Gibt es auch abweichende Vorgaben für die Unterspannungsschwellen, so müssen zusätzlich Parameter .015 ($U_{<off}$) und .031 ($U_{<<off}$) angepasst werden.

Hinweis: In Niederspanngs.netzen wird die Nennspanng. U_n bezeichnet und in Mittelspanngs.netzen U_c .

4.4.2 FRT (Fault Ride Through) Fähigkeit von Stromerzeugungsanlagen:

Die FRT-Fähigkeit muss für die unterschiedlichen Komponenten einer Stromerzeugungsanlage getrennt voneinander betrachtet werden. Die FRT-Fähigkeit von Trennschützen wird in Kapitel 2.6 dargestellt, dabei muss der Errichter der Stromerzeugungsanlage dafür sorgen, dass für die Trennschütze ausreichend Pufferung zur Verfügung steht.

Der Errichter der Stromerzeugungsanlage muss zusätzlich darauf achten, dass sich die Anforderungen aus der FRT (Unterschiedliche Anforderungen zwischen den Ländern) und den Schutzeinstellungen für Unterspannung (Höhe $U < U_{<<}$ und Time OFF) nicht gegenseitig beeinflussen.

Sollte der NA003 Versorgungsseitig (A1/A2) mit dem Hauptnetz verbunden sein (nicht getrennt vom Messkreis versorgt) kann gewährleistet werden, dass folgende FRT-Anforderungen aus der TOR 1.1 und VDE-AR-N 4105:2018 problemlos (auch öfters hintereinander) durchlaufen werden können, ohne dass die Ausgangsrelais R1/R2 fälschlicherweise bedingt durch das interne Netzteil abfallen.

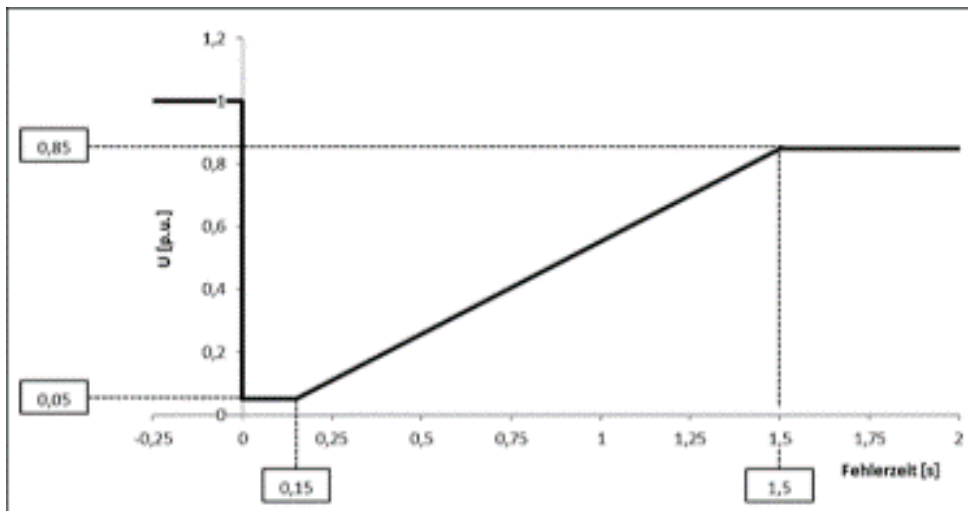

(FRT-Profil nichtsynchrone Stromerzeugungsanlagen nach TOR 1.1 2019; ausgewählt, weil schwierigstes Verhalten für das interne Netzteil des NA-Schutzes)

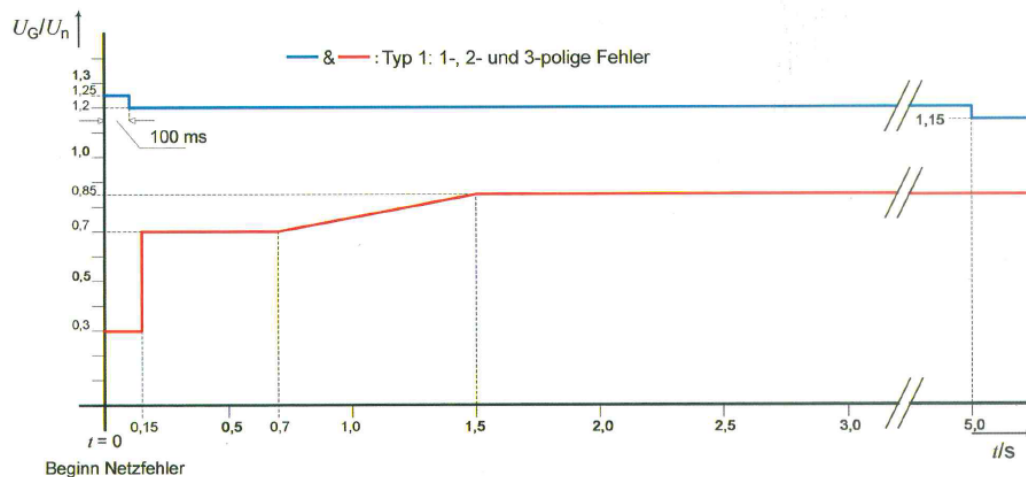

Legende

- & — FRT-Kurve für 1-, 2- und 3-polige Netzfehler
- U_G Effektivwert der aktuellen Spannung an den Generatorklemmen

(FRT-Profil nach VDE-AR-N 4105:2018 Typ1- nur Synchrongeneratoren)

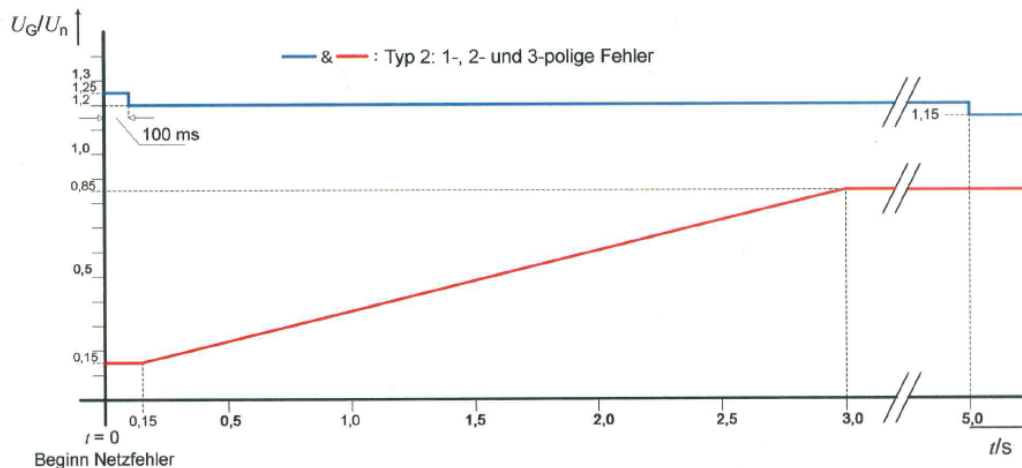

Legende

- & — FRT-Kurve für 1-, 2- und 3-polige Netzfehler
- UG Effektivwert der aktuellen Spannung an den Generatorklemmen

(FRT-Profil nach VDE-AR-N 4105:2018 Typ2- Umrichter und andere)

Dieses FRT-Verhalten gilt für den gesamten AC-Versorgungsbereich 110-230VAC, für eine Versorgung mit 24VDC ist das FRT-Verhalten (kein Abfallen der Ausgangsrelais R1/R2) nicht gewährleistet. In diesem Fall muss der Errichter der Stromerzeugungsanlage für eine ausreichende Pufferung der 24VDC Sorge tragen (Geräteverbrauch 1,25W/4VA).

Sollte es zu einem komplett-Ausfall z.B. von L1 kommen, während A1 und A2 des NA-Schutzes mit L1 und N verbunden sind, kann das interne Netzteil des NA-Schutzes bei

- 230VAC <580ms
- 110VAC <200ms
- 24VDC < 70ms (NA-Schutz getrennt vom Messkreis versorgt)

überbrücken, sprich es kommt weder zu einem Reset des NA-Schutzes noch fallen die Relais R1/2 ab. Die genannte Überbrückung betrifft aber nur den NA003-M64. Hängt der NA003-M64 A1/A2 mit den Trennschützen zusammen an A1/A2, muß immer eine eigene Berechnung mit dem Eigenverbrauch der Trennschütze durchgeführt werden.

4.4.3 Selbsthalteschaltung für Fernabschaltung mit manueller Freigabe

Für spezielle Anwendungen kann vom Netzbetreiber gefordert werden, dass nach einer Fernabschaltung erst wieder manuell freigegeben (zugeschaltet) werden darf. Das ist momentan durch die Verwirklichung einer Selbsthalteschaltung möglich:

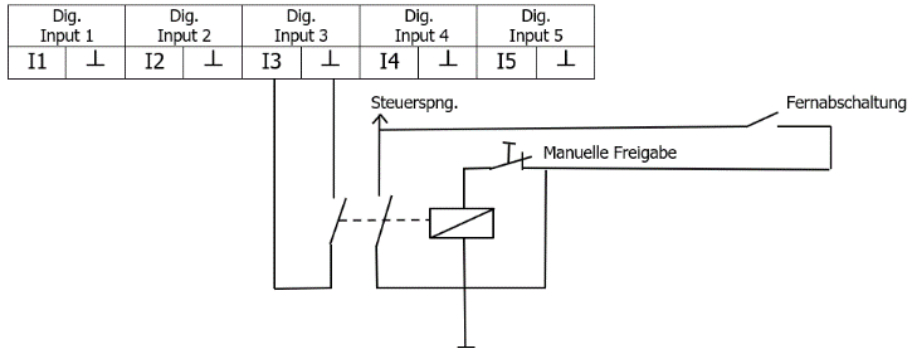

4.4.4 Anschluß eines Rundsteuerempfängers für Leistungsreduktion 0%

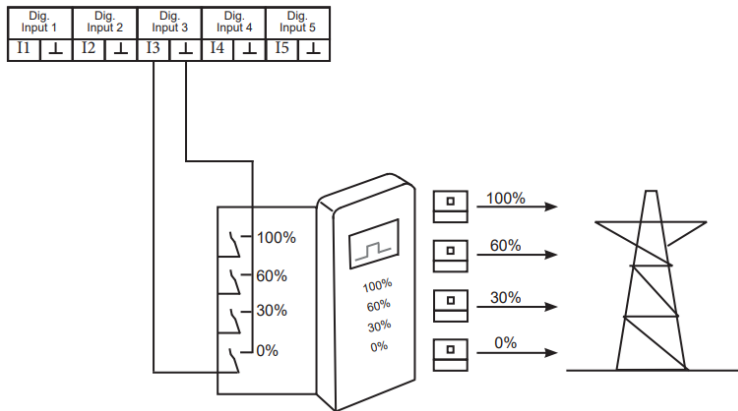

4.5 Versorgungskreis

Klemmen	A1 (L bzw. +); A2 (N bzw. -)
Versorgungsspannung	DC: 24V AC: 110 - 230V
Toleranz der Versorgungsspannung	DC: $\pm 10\%$ AC: $\pm 30\%$
Nennverbrauch	max. 1,25W / 4VA @ 230V AC
Nennfrequenz	50 / 60Hz
Toleranz der Nennfrequenz	48 - 63Hz
Einschaltdauer	100%
Wiederbereitschaftszeit	6 Sekunden + eingestellte Einschaltverzögerung
Abfallspannung	7V
Überspannungskategorie	III
Bemessungsstoßspannung	6 kV
Interne Absicherung	250V / 500mA träge (eingelötet)

Um die Gerätefunktion während eines Netzausfall zu gewährleisten, ist das Gerät über eine externe USV-Anlage zu versorgen!

4.6 Messkreis

Klemmen	L1-L2-L3-N
Messeingang	3x 400V AC
Eingangswiderstand	1M Ω
Messgrößen	Außenleiterspannung, Sternspannung, 10 Minuten Spannungsmittelwert, Frequenz, Frequenzänderung (RoCoF), Phasensprung (PShift), Zero Sequence

4.7 Messbereiche

Außenleiterspannung	0 - 560VAC
Sternspannung	0 - 325VAC
Frequenz	40 - 65Hz (gemessen zw. L1/N)
RoCoF	100mHz/s - 2.000mHz/s
Pshift	1 - 15°
Überlastbarkeit	Dauerhaft 1,4 x U _{Nom} Impuls 1,6 x U _{Nom} (1 Sekunde)
Überspannungskategorie	III
Bemessungsstoßspannung	4 kV

4.8 Digitale Eingänge

Klemmen	I1 und ⊥ ; I2 und ⊥ ; I3 und ⊥ ; I4 bzw. I5 und ⊥ I1, I2, I3 können als n.c., n.o. und dis. konfiguriert werden
Kontaktart	Potentialfrei (max. Leitungslänge 30m, Verlegung als Steuerleitung, getrennt von Energiekabeln)
Schaltleistung	24V DC / 5mA

4.9 Ausgangskreis

Klemmen	11-12-14; 21-22-24; 31-32-34
Anzahl und Art der Kontakte	3 Wechsler
Kontaktmaterial	AgNi
Schaltleistung	5A / 250V AC
Schalhäufigkeit elektrisch (AC-1)	100 x 10 ³ Schaltspiele
Schalhäufigkeit mechanisch	15 x 10 ⁶ Schaltspiele
Dauerlast	5A
Impulslast (1s)	5A
Spannungsfestigkeit offener Kontakte	Relaiskontakte: 1000V _{rms} Klemmen: 450V _{rms}
Überspannungskategorie	III
Bemessungsstoßspannung	4 kV
Absicherung	5A flink

4.10 Genauigkeit

Spannungsmessung:	
Grundgenauigkeit	< 0,5% @ +25°C
Temperatureinfluss	< 0,01%/°C
Auflösung	10mV
Frequenzmessung:	
Grundgenauigkeit	< 0,01Hz @ +25°C
Temperatureinfluss	< 0,0002Hz/°C
Auflösung	1mHz
Anlaufverzögerung Ton delay	0...600s ± 0,6%
Ansprechverzögerung (TIME OFF) t _{UTHR OFF}	0...300s ± 0,6%
Rückfallverzögerung t _{UTHR ON_total}	130ms ± 45%
Ansprechverz. bei Überspng. t _{over}	95ms ± 50%
Ansprechverz. bei Unterspng. t _{under}	95ms ± 40%
Ansprechzeit, t _{off_total_over/under}	t _{off_total_over} = t _{over} + t _{UTHR OFF} t _{off_total_under} = t _{under} + t _{UTHR OFF}
Überschwingzeit	40ms

4.11 Isolationsdaten

Bemessungsisolationsspannung	400V
Isolierung	
Versorgungskreis / Messkreis	Sichere Trennung
Versorgungskreis / Ausgangskreis	Sichere Trennung
Versorgungskreis / Digitale Eingänge	Sichere Trennung
Ausgangskreis / Messkreis	Basisisolierung
Ausgangskreis / Digitale Eingänge	Basisisolierung

4.12 Umgebungsbedingungen

Umgebungstemperatur Betrieb	-25 bis +65°C
Umgebungstemperatur Lagerung	-40 bis +70°C
Anzeigefähigkeit Display	-15 bis +65°C
Relative Luftfeuchtigkeit	5 bis 95%
Verschmutzungsgrad	2
Gewicht	300g
MTTF	93.000h (für Displaytemperatur 25°C +/-5°C)

4.13 Elektrischer Anschluss

Anschlussquerschnitt	max. 2,5mm ²
Abisolierlänge	max. 8mm
Elektrische Belastbarkeit der Klemmen: Relaisausgänge / Digitale Eingänge Messeingänge	max. 450V/16A max. 750V/16A
Anzugsdrehmoment	max. 0,5Nm
Schraube	M3, Längsschlitz für Schraubendreher 0,6 x 3,5mm
Digitale Eingänge und Ausgangsrelais	Keine Beschränkung für gleichzeitigen Betrieb von Ein- und Ausgängen.

4.14 Plombier Draht

Drahtdurchmesser	Ø max. 1,32mm
------------------	---------------

4.15 Schutzart

Klemmen	IP 20
Gehäuse	IP 20

5 Settings der implementierten Parametersätze

Definition zu den folgenden Tabellen:

Grau hinterlegte Zeilen bedeuten, dass die zugehörigen Parameter editierbar sind. Alle anderen Parameter sind nicht verstellbar.

5.1.1 Connection Modes

2-wire	Es wird nur die Spannung zwischen L1 und N ausgewertet
3-wire	Es werden nur die Außenleiterspannungen U_{L1-L2} , U_{L2-L3} und U_{L3-L1}
4-wire (LN)	Es werden nur die Sternleiterspannungen U_{L1-N} , U_{L2-N} und U_{L3-N} ausgewertet
4-wire (LN+LL)	Es werden sowohl die Sternspannungen U_{L1-N} , U_{L2-N} und U_{L3-N} als auch die Außenleiterspannungen U_{L1-L2} , U_{L2-L3} und U_{L3-L1} ausgewertet

5.1.2 Einheiten

%Unom	Prozent der Nennspannung (Nennspannungsfaktor)
-------	--

5.1.3 Funktionale Sicherheit

Errtol 2ch	es werden 2 getrennte Schütze mit 2 getrennten Hilfskontakten angeschlossen
Errtol 1ch	es wird 1 externer Schütz mit 1 Hilfskontakt angeschlossen

5.1.4 Operational Mode

Hier kann zwischen 2 verschiedenen Betriebsmodi umgeschaltet werden
Wird momentan nur für die CEI-021 verwendet

Mode 0:	transitory mode
Mode 1:	definitive mode

5.1.5 Schwellen

U_{THR} OFF	Spannungsschwelle für Abschaltung
U_{THR} ON	Spannungsschwelle für Zuschaltung
f_{THR} OFF	Frequenzschwelle für Abschaltung
f_{THR} ON	Frequenzschwelle für Zuschaltung
RoCoF _{THR} OFF	Frequenzänderungsschwelle für Abschaltung
RoCoF _{THR} ON	Frequenzänderungsschwelle für Zuschaltung
PShift _{THR} OFF	Phasensprungschwelle für Abschaltung
PShift _{THR} ON	Phasensprungschwelle für Zuschaltung

5.1.6 Zeiten

Time OFF	Abschaltverzögerung
T on delay	Einschaltverzögerung
F wnd Ermittlung	window length frequency measuring (beobachtetes Zeitfenster, das für die der Frequenzgröße f / Hz herangezogen wird, einstellbar von 0,1s bis 1s abhängig vom verwendeten Parametersatz)
RoCoF wnd	window length RoCoF (Rate of Change of Frequency) measuring (beobachtetes Zeitfenster, das für die Ermittlung des RoCoF Hz/s herangezogen wird, einstellbar von 0,1s bis 1s abhängig vom verwendeten Parametersatz)
PShift wnd	window length PShift (Phase Shift) measuring (beobachtetes Zeitfenster, das für die Ermittlung des PShift / ° herangezogen wird, einstellbar von 0,1s bis 1s abhängig vom verwendeten Parametersatz, wobei nur eine Einstellung von 0,1 bis 0,6s Sinn ergibt. Ein Pshift wnd von 0,6s bis 1s wirkt sich nicht auf die Gesamtabschaltverzögerung aus)
Gesamtabschaltverz. zusammen:	Diese setzt sich bei der Messung von Frequenz, RoCoF oder Pshift wie folgt zusammen: Frequenz Messung: $\text{TIME OFF}_{\text{gesamt}f} = \text{Time OFF}_f + F \text{ wnd}$ RoCoF-Messung: $\text{TIME OFF}_{\text{gesamtRoCoF}} = \text{Time OFF}_{\text{RoCoF}} + \text{RoCoF wnd}$ Phase Shift Messung: $\text{TIME OFF}_{\text{gesamtPShift}} = \text{Time OFF}_{\text{PShift}} + \text{PShift wnd}$

5.1.7 Hilfskontakt

Bei geforderter funktionaler Sicherheit ist das Rücklesen der Stellung der angesteuerten Schütze (über zwangsgeführte Hilfskontakte) notwendig. Für diese Hilfskontakte kann folgendes ausgewählt werden:

Contact n.c. (normally closed)	Hilfskontakt ist ein Öffner (empfohlene Ausführung)
Contact n.o. (normally opened)	Hilfskontakt ist ein Schließer
Contact dis. (disabled)	Hilfskontakt wird ignoriert (unzulässig für Standards die funktionale Sicherheit fordern)
Contact t	Einstellung der Zeit beim Abschalten, die vergehen darf, bis der Hilfskontakt an I1/2 zurückmelden muss, ansonsten anzeigen eines contact errors
T ConDelOn	Einstellung der Zeit beim Zuschalten die vergehen darf, bis der Hilfskontakt des Kuppelschalters an den Klemmen I1/2 zurückmelden muss. Andernfalls wird R1/2 abgeschaltet und ein contact error angezeigt. Zusätzlich wird R3 aktiviert.

5.1.8 Ranges

Conformity Range	Innerhalb dieser Grenzen, ist das Gerät normkonform konfiguriert. Außerhalb dieser Grenzen ist das Gerät nicht mehr normkonform und die entsprechenden Zertifikate verlieren ihre Gültigkeit. Dieser Status wird am Display durch die Kennung „ncnf“ dargestellt. Einstellungen außerhalb dieses Bereiches liegen somit in der Verantwortung des Betreibers und/oder der Abnahmestelle der Anlage.
Possible Range	Technisch möglicher Einstellbereich

6 Sicherheitskonzept

Das System besteht aus drei Microkontrollern. CH_A und CH_B sind die Messkanäle. Diese erfassen, berechnen und überwachen die Messwerte, lesen den Eingang für den Rückmeldekontakt ein und schalten eigenständig das zugehörige Relais. Beide Messkanäle sind redundant aufgebaut (u.a. Spannungsreferenz, Zeitbasis). Der dritte Controller CH_D überwacht beide Messkanäle auf Abweichungen, steuert die Benutzerschnittstelle (LEDs, Display, Tasten) und kontrolliert nicht sicherheitsrelevante Ein- und Ausgänge.

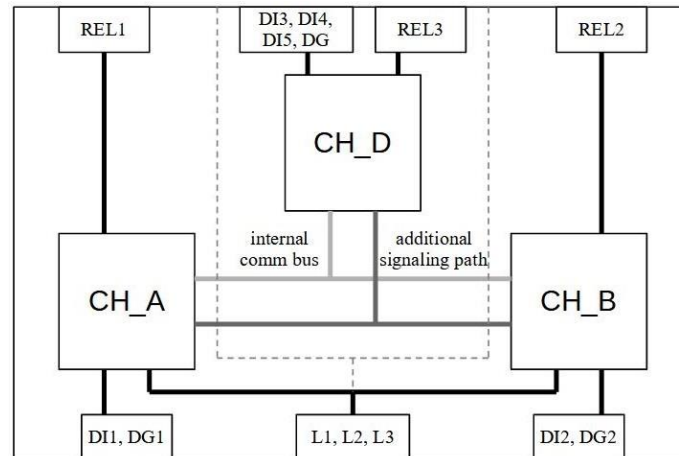

Fehlerbehandlung

Fehler werden in drei Klassen eingeteilt:

1. **Grenzwertüberschreitung**

Dabei handelt es sich um einen normalen Betriebszustand. Dazu zählt unter anderem die Erkennung einer Überspannung oder Unterfrequenz. Diese Fehler werden nach der normativen Spezifikation behandelt. Normalerweise werden die Relais von CH_A und CH_B nach einer Auslöseverzögerung abgeworfen. Nachdem der Fehler nicht mehr erkannt wird und alle anderen Parameter innerhalb der zulässigen Grenzen sind, werden die Relais nach einer Einschaltverzögerung wieder zugeschaltet.

2. **Nicht kritische Systemfehler**

Diese Fehler deuten auf ein Problem hin, sind aber nicht sicherheitskritisch. Dazu zählen eine zu niedrige Versorgungsspannung, ein als offen erkannter Rückmeldekontakt, der geschlossen sein sollte oder vereinzelt Fehler in der internen Kommunikation.

3. **Kritische Systemfehler**

Diese Fehler sind sicherheitskritische Fehler. Dazu zählen unter anderem eine zu hohe Messabweichung der beiden Messkanäle, die Speicherintegrität ist nicht gegeben. Wird ein solcher Fehler erkannt, geht das System in den Sicherheitszustand (Relais im Ruhezustand- OFF).

Systemfehler:

- T Fernabschaltung aktiv
- 0 CH_A oder CH_B enthält ungültige Software (CODEID)
- 1 Software in CH_A und CH_B ist unterschiedlich (CODEVERS)
- 2 Fehlerhafte Prüfsumme des Codespeicher (CODECRC)
- 3 Fehlerhafte Prüfsumme der Firmware (derzeit nicht verwendet - FLASHCRC)
- 4 Fehlerhafte Prüfsumme des EEPROM (EEPROMCRC)
- 5 Konfiguration ist inkonsistent (LOGICVERS)
- 6 Fehlerhafte Prüfsumme der Konfiguration (LOGICCRC)
- 7 Reserviert
- 8 Fehler in der Versorgungsspannung für die Ausgänge (POWER6V)
- 9 Fehler in der Versorgungsspannung für die Eingänge (POWERDIGINP)
- A Abweichung der Messkanäle (MEASCOMPAB)
- B Password-Abfrage deaktiviert (PWDINACTIVE)
- C Messkanal kommuniziert intern nicht (INTERCOM1)
- D Reserviert
- E Reserviert
- F Reserviert

7 Glossar

OVE	Österreichischer Verband für Elektrotechnik
TOR	Technische und organisatorische Regeln (Österreich)
OOE	Oberösterreich
W	Wien
NS	Niederspannung
MS	Mittelspannung
VDE	Verband der Elektrotechnik
AR	Anschlußregeln
NA/EEA- CH	Netzanlagen/Eigenerzeugungsanlagen-Schweiz
AS	Australien
NZS	Neuseeland
DK	Dänemark
IP	Interface Protection
ASS	Automatic Separation System

8 Verfügbare Normen und Standards

Slot	ID	Norm/Standard	Regions	Number of channels		
				1	2 Funct. safety	1 or 2 select able
#00	802	OVE TOR R25 NS SYNC	Austria (low voltage)		X	
#01	803	OVE TOR R25 NS ASYNC	Austria (low voltage)		X	
#02	852	OVE TOR R25 MS SYNC	Austria (medium voltage)		X	
#03	853	OVE TOR R25 MS ASYNC	Austria (medium voltage)		X	
#04	822	OOE TOR R25 NS SYNC	Upper Austria Oberösterreich (low voltage)		X	
#05	823	OOE TOR R25 NS ASYNC	Upper Austria Oberösterreich (low voltage)		X	
#06	872	OOE TOR R25 MS SYNC	Upper Austria Oberösterreich (medium voltage)		X	
#07	873	OOE TOR R25 MS ASYNC	Upper Austria Oberösterreich (medium voltage)		X	
#08	832	W TOR R25 NS SYNC	Vienna (low voltage)		X	
#09	833	W TOR R25 NS ASYNC	Vienna (low voltage)		X	
#10	882	W TOR R25 MS SYNC	Vienna (medium voltage)		X	
#11	883	W TOR R25 MS ASYNC	Vienna (medium voltage)		X	
#12	812	TIROL TOR NS SYNC	Tyrol (low voltage)		X	
#13	813	TIROL TOR NS ASYNC	Tyrol (low voltage)		X	
#14	862	TIROL TOR MS SYNC	Tyrol (medium voltage)		X	
#15	863	TIROL TOR MS ASYNC	Tyrol (medium voltage)		X	
#16	311	VDE-AR-N 4105: 2018 (Pn ≤ 50kW)	Germany (low voltage)	X		

#17	312	VDE-AR-N 4105: 2018 (Pn > 50kW)	Germany (low voltage)	X		
#18	313	VDE-AR-N 4105: 2018 (converter)	Germany (low voltage)		X	
#19	706	VDE-AR-N 4110: 2018 (Pn > 135kW)	Germany (medium voltage)	X		
#20	102	CEI 0-21: 2019	Italy	X		
#21	410	G99/1/3: 2018 LV	Great Britain (low voltage)	X		
#22	460	G99/1/3: 2018 HV	Great Britain (medium/high voltage)	X		
#23	510	G98/1/2: 2018	Great Britain (low voltage)	X		
#24	603	C10-11: 2021 LV-IP	Belgium (low voltage) interface protection	X		
#25	602	C10-11: 2019 LV-ASS	Belgium (low voltage) automatic separation system	X		
#26	653	C10-11: 2021 HV-IP	Belgium (medium/high voltage) interface protection	X		
#27	652	C10-11: 2019 HV-ASS	Belgium (medium/high voltage) automatic separation system	X		
#28	1200	NA/EEA- CH 2014 (Type A)	Switzerland 2014 (low voltage)		X	
#29	1220	NA/EEA-NE7 - CH 2020 (Type A)	Switzerland 2020 (low voltage)		X	
#30	1221	NA/EEA-NE7 - CH 2020 (Type B)	Switzerland 2020 (low voltage)		X	
#31	901	EN 50549-1:2019	Europe LV (Netherlands)		X	
#32	902	EN 50549-2:2019	Europe HV (Netherlands)		X	
#33	950	EN 50438: 2013 DK	Denmark			X
#34	200	VDE V 0126-1-1:2013	France, Turkey, Belgium, Greece, ...		X	
#35	1110	AB AS 4777.2:2020	Australia		X	

#36	1120	C AS 4777.2:2020	Australia		X	
#37	1130	NZS 4777.2:2020	New Zealand		X	
#38	1000	NRS 097-2-1: 2017	South Africa		X	
#39	9006	OPEN SETUP	Freely configurable setup			X

Recertified Standards						
#52	900	EN 50438:2013	Europe		X	
#53	801	OVE E 8001/8101:2014	Austria		X	
#54	300	VDE-AR-N 4105 tested according to VDE 0124-100:2013	Germany (low voltage)		X	
#55	700	TR3 Rev23:2013 certified according to BDEW 2008	Germany (medium voltage)	X		
#56	1102	AS/NZS 4777.2:2015	Australia / Victoria (New Zealand)		X	
#57	405	G59/3/3: 2015 LV	Great Britain (low voltage)	X		
#58	455	G59/3/3: 2015 MV	Great Britain (high voltage)	X		
#59	500	G83/2: 2012	Great Britain (low voltage)	X		
#60	600	C10-11: 2012 LV	Belgium (low voltage)	X		
#61	650	C10-11: 2012 MV	Belgium medium voltage	X		
#62	601	C10-11: 2019 LV	Belgium (low voltage)	X		
#63	651	C10-11: 2019 HV	Belgium (high voltage)	X		

9 Übersicht der implementierten Parametersätze

9.1 OVE TOR R25 NS SYNC (Typ A/B Niederspng. für synchrone Stromerzeugungsanlagen)

- Auswählbarer Connection Mode (1 phasig, 3 phasig)
- Auswählbare Nennspannung
- Auswählbarer Rückmeldekontakt (Öffner / Schließer)
- Auswählbare Fernabschaltung (Öffner / Schließer)
- 2 Überspannungsschwellen - Sternspannung
- 2 Unterspannungsschwellen - Sternspannung
- 10-Minuten Mittelwert Überspannungsschwelle
- 1 Überfrequenzschwelle
- 1 Unterfrequenzschwelle
- Einschaltverzögerung
- Melderelais R3 - Aktivierung (LED R3 ON) bei Ansprechen einer Schutzfunktion U/f oder bei Fehler Rückmeldekontakt

9.2 OVE TOR R25 NS ASYNC (Typ A/B Niederspng. für nicht syncr. Stromerzeugungsanlagen)

- Auswählbarer Connection Mode (1 phasig, 3 phasig)
- Auswählbare Nennspannung
- Auswählbarer Rückmeldekontakt (Öffner / Schließer)
- Auswählbare Fernabschaltung (Öffner / Schließer)
- 2 Überspannungsschwellen - Sternspannung
- 2 Unterspannungsschwellen - Sternspannung
- 10-Minuten Mittelwert Überspannungsschwelle
- 1 Überfrequenzschwelle
- 1 Unterfrequenzschwelle
- Einschaltverzögerung
- Melderelais R3 - Aktivierung (LED R3 ON) bei Ansprechen einer Schutzfunktion U/f oder bei Fehler Rückmeldekontakt

9.3 OVE TOR R25 MS SYNC (Typ A/B Mittelspng. für synchrone Stromerzeugungsanlagen)

- Auswählbarer Connection Mode (1 phasig, 3 phasig)
- Auswählbare Nennspannung
- Auswählbarer Rückmeldekontakt (Öffner / Schließer)
- Auswählbare Fernabschaltung (Öffner / Schließer)
- 2 Überspannungsschwellen - Außenleiterspannung
- 2 Unterspannungsschwellen - Außenleiterspannung
- 1 Überfrequenzschwelle
- 1 Unterfrequenzschwelle
- Einschaltverzögerung
- Melderelais R3 - Aktivierung (LED R3 ON) bei Ansprechen einer Schutzfunktion U/f oder bei Fehler Rückmeldekontakt

9.4 OVE TOR R25 MS ASYNC (Typ A/B Mittelspng. für nicht synchr. Stromerzeugungsanlagen)

- Auswählbarer Connection Mode (1 phasig, 3 phasig)
- Auswählbare Nennspannung
- Auswählbarer Rückmeldekontakt (Öffner / Schließer)
- Auswählbare Fernabschaltung (Öffner / Schließer)
- 2 Überspannungsschwellen - Außenleiterspannung
- 2 Unterspannungsschwellen - Außenleiterspannung
- 1 Überfrequenzschwelle
- 1 Unterfrequenzschwelle
- Einschaltverzögerung
- Melderelais R3 - Aktivierung (LED R3 ON) bei Ansprechen einer Schutzfunktion U/f oder bei Fehler Rückmeldekontakt

9.5 OOE TOR R25 NS SYNC (Typ A/B Niederspng. für synchrone Stromerzeugungsanlagen)

- Auswählbarer Connection Mode (1 phasig, 3 phasig)
- Auswählbare Nennspannung
- Auswählbarer Rückmeldekontakt (Öffner / Schließer)
- Auswählbare Fernabschaltung (Öffner / Schließer)
- 1 Überspannungsschwellen - Sternspannung
- 2 Unterspannungsschwellen - Sternspannung
- 10-Minuten Mittelwert Überspannungsschwelle
- 1 Überfrequenzschwelle
- 1 Unterfrequenzschwelle
- Einschaltverzögerung
- Melderelais R3 - Aktivierung (LED R3 ON) bei Ansprechen einer Schutzfunktion U/f oder bei Fehler Rückmeldekontakt

9.6 OOE TOR R25 NS ASYNC (Typ A/B Niederspng. für nicht synchr. Stromerzeugungsanlagen)

- Auswählbarer Connection Mode (1 phasig, 3 phasig)
- Auswählbare Nennspannung
- Auswählbarer Rückmeldekontakt (Öffner / Schließer)
- Auswählbare Fernabschaltung (Öffner / Schließer)
- 1 Überspannungsschwellen - Sternspannung
- 2 Unterspannungsschwellen - Sternspannung
- 10-Minuten Mittelwert Überspannungsschwelle
- 1 Überfrequenzschwelle
- 1 Unterfrequenzschwelle
- Einschaltverzögerung
- Melderelais R3 - Aktivierung (LED R3 ON) bei Ansprechen einer Schutzfunktion U/f oder bei Fehler Rückmeldekontakt

9.7 OOE TOR R25 MS SYNC (Typ A/B Mittelspng. für synchrone Stromerzeugungsanlagen)

- Auswählbarer Connection Mode (1 phasig, 3 phasig)
- Auswählbare Nennspannung
- Auswählbarer Rückmeldekontakt (Öffner / Schließer)
- Auswählbare Fernabschaltung (Öffner / Schließer)
- 2 Überspannungsschwellen - Außenleiterspannung
- 2 Unterspannungsschwellen - Außenleiterspannung
- 10-Minuten Mittelwert Überspannungsschwelle
- 1 Überfrequenzschwelle
- 1 Unterfrequenzschwelle
- Einschaltverzögerung
- Melderelais R3 - Aktivierung (LED R3 ON) bei Ansprechen einer Schutzfunktion U/f oder bei Fehler Rückmeldekontakt

9.8 OOE TOR R25 MS ASYNC (Typ A/B Mittelspng. für nicht synchr. Stromerzeugungsanlagen)

- Auswählbarer Connection Mode (1 phasig, 3 phasig)
- Auswählbare Nennspannung
- Auswählbarer Rückmeldekontakt (Öffner / Schließer)
- Auswählbare Fernabschaltung (Öffner / Schließer)
- 2 Überspannungsschwellen - Außenleiterspannung
- 2 Unterspannungsschwellen - Außenleiterspannung
- 10-Minuten Mittelwert Überspannungsschwelle
- 1 Überfrequenzschwelle
- 1 Unterfrequenzschwelle
- Einschaltverzögerung
- Melderelais R3 - Aktivierung (LED R3 ON) bei Ansprechen einer Schutzfunktion U/f oder bei Fehler Rückmeldekontakt

9.9 W TOR R25 NS SYNC (Typ A/B Niederspng. für synchrone Stromerzeugungsanlagen)

- Auswählbarer Connection Mode (1 phasig, 3 phasig)
- Auswählbare Nennspannung
- Auswählbarer Rückmeldekontakt (Öffner / Schließer)
- Auswählbare Fernabschaltung (Öffner / Schließer)
- 2 Überspannungsschwellen - Sternspannung
- 2 Unterspannungsschwellen - Sternspannung
- 10-Minuten Mittelwert Überspannungsschwelle
- 1 Überfrequenzschwelle
- 1 Unterfrequenzschwelle
- Einschaltverzögerung
- Melderelais R3 - Aktivierung (LED R3 ON) bei Ansprechen einer Schutzfunktion U/f oder bei Fehler Rückmeldekontakt

9.10 W TOR R25 NS ASYNC (Typ A/B Niederspng. für nicht synchron. Stromerzeugungsanlagen)

- Auswählbarer Connection Mode (1 phasig, 3 phasig)
- Auswählbare Nennspannung
- Auswählbarer Rückmeldekontakt (Öffner / Schließer)
- Auswählbare Fernabschaltung (Öffner / Schließer)
- 2 Überspannungsschwellen - Sternspannung
- 2 Unterspannungsschwellen - Sternspannung
- 10-Minuten Mittelwert Überspannungsschwelle
- 1 Überfrequenzschwelle
- 1 Unterfrequenzschwelle
- Einschaltverzögerung
- Melderelais R3 - Aktivierung (LED R3 ON) bei Ansprechen einer Schutzfunktion U/f oder bei Fehler Rückmeldekontakt

9.11 W TOR R25 MS SYNC (Typ A/B Mittelspng. für synchrone Stromerzeugungsanlagen)

- Auswählbarer Connection Mode (1 phasig, 3 phasig)
- Auswählbare Nennspannung
- Auswählbarer Rückmeldekontakt (Öffner / Schließer)
- Auswählbare Fernabschaltung (Öffner / Schließer)
- 2 Überspannungsschwellen - Außenleiterspannung
- 2 Unterspannungsschwellen - Außenleiterspannung
- 1 Überfrequenzschwelle
- 1 Unterfrequenzschwelle
- Einschaltverzögerung
- Melderelais R3 - Aktivierung (LED R3 ON) bei Ansprechen einer Schutzfunktion U/f oder bei Fehler Rückmeldekontakt

9.12 W TOR R25 MS ASYNC (Typ A/B Mittelspng. für nicht synchron. Stromerzeugungsanlagen)

- Auswählbarer Connection Mode (1 phasig, 3 phasig)
- Auswählbare Nennspannung
- Auswählbarer Rückmeldekontakt (Öffner / Schließer)
- Auswählbare Fernabschaltung (Öffner / Schließer)
- 2 Überspannungsschwellen - Außenleiterspannung
- 2 Unterspannungsschwellen - Außenleiterspannung
- 1 Überfrequenzschwelle
- 1 Unterfrequenzschwelle
- Einschaltverzögerung
- Melderelais R3 - Aktivierung (LED R3 ON) bei Ansprechen einer Schutzfunktion U/f oder bei Fehler Rückmeldekontakt

9.13 TIROL TOR NS SYNC (Typ A/B Niederspng. für synchrone Stromerzeugungsanlagen)

- Auswählbarer Connection Mode (1 phasig, 3 phasig)
- Auswählbare Nennspannung
- Auswählbarer Rückmeldekontakt (Öffner / Schließer)
- Auswählbare Fernabschaltung (Öffner / Schließer)
- 2 Überspannungsschwellen - Sternspannung
- 2 Unterspannungsschwellen - Sternspannung
- 10-Minuten Mittelwert Überspannungsschwelle
- 1 Überfrequenzschwelle
- 1 Unterfrequenzschwelle
- Einschaltverzögerung
- Melderelais R3 - Aktivierung (LED R3 ON) bei Ansprechen einer Schutzfunktion U/f oder bei Fehler Rückmeldekontakt

9.14 TIROL TOR NS ASYNC (Typ A/B Niederspng. für nicht synchr. Stromerzeugungsanlagen)

- Auswählbarer Connection Mode (1 phasig, 3 phasig)
- Auswählbare Nennspannung
- Auswählbarer Rückmeldekontakt (Öffner / Schließer)
- Auswählbare Fernabschaltung (Öffner / Schließer)
- 2 Überspannungsschwellen - Sternspannung
- 2 Unterspannungsschwellen - Sternspannung
- 10-Minuten Mittelwert Überspannungsschwelle
- 1 Überfrequenzschwelle
- 1 Unterfrequenzschwelle
- Einschaltverzögerung
- Melderelais R3 - Aktivierung (LED R3 ON) bei Ansprechen einer Schutzfunktion U/f oder bei Fehler Rückmeldekontakt

9.15 TIROL TOR MS SYNC (Typ A/B Mittelspng. für synchrone Stromerzeugungsanlagen)

- Auswählbarer Connection Mode (1 phasig, 3 phasig)
- Auswählbare Nennspannung
- Auswählbarer Rückmeldekontakt (Öffner / Schließer)
- Auswählbare Fernabschaltung (Öffner / Schließer)
- 2 Überspannungsschwellen - Außenleiterspannung
- 2 Unterspannungsschwellen - Außenleiterspannung
- 1 Überfrequenzschwelle
- 1 Unterfrequenzschwelle
- Einschaltverzögerung
- Melderelais R3 - Aktivierung (LED R3 ON) bei Ansprechen einer Schutzfunktion U/f oder bei Fehler Rückmeldekontakt

9.16 TIROL TOR MS ASYNC (Typ A/B Mittelspng. für nicht synchr. Stromerzeugungsanlagen)

- Auswählbarer Connection Mode (1 phasig, 3 phasig)
- Auswählbare Nennspannung
- Auswählbarer Rückmeldekontakt (Öffner / Schließer)
- Auswählbare Fernabschaltung (Öffner / Schließer)
- 2 Überspannungsschwellen - Außenleiterspannung
- 2 Unterspannungsschwellen - Außenleiterspannung
- 1 Überfrequenzschwelle
- 1 Unterfrequenzschwelle
- Einschaltverzögerung
- Melderelais R3 - Aktivierung (LED R3 ON) bei Ansprechen einer Schutzfunktion U/f oder bei Fehler Rückmeldekontakt

9.17 VDE-AR-N 4105:2018-11 ($P_n \leq 50 \text{ kW}$)

- Auswählbarer Connection Mode (1 phasig, 3 phasig)
- Auswählbarer Rückmeldekontakt (Öffner / Schließer)
- Zusätzliche zeitliche Überwachung des Rückmeldekontaktes beim Zuschalten
- Auswählbare Fernabschaltung (Öffner / Schließer)
- 1 Überspannungsschwelle - Außenleiterspannung
- 1 Unterspannungsschwelle - Außenleiterspannung
- 1 Überspannungsschwelle - Sternspannung
- 1 Unterspannungsschwelle - Sternspannung
- 10-Minuten Mittelwert Überspannungsschwelle
- 1 Überfrequenzschwelle
- 1 Unterfrequenzschwelle
- 1 zufällige Überfrequenzschwelle (bei Bedarf aktivierbar)
- Einschaltverzögerung
- zufällige Einschaltverzögerung (bei Bedarf aktivierbar)
- Melderelais R3 - Aktivierung (LED R3 ON) bei Fehler Rückmeldekontakt

9.18 VDE-AR-N 4105:2018-11 ($P_n > 50 \text{ kW}$)

- Auswählbarer Connection Mode (1 phasig, 3 phasig)
- Auswählbarer Rückmeldekontakt (Öffner / Schließer)
- Zusätzliche zeitliche Überwachung des Rückmeldekontaktes beim Zuschalten
- Auswählbare Fernabschaltung (Öffner / Schließer)
- 1 Überspannungsschwelle - Außenleiterspannung
- 2 Unterspannungsschwellen - Außenleiterspannung
- 1 Überspannungsschwelle - Sternspannung
- 2 Unterspannungsschwellen - Sternspannung
- 10-Minuten Mittelwert Überspannungsschwelle
- 1 Überfrequenzschwelle
- 1 Unterfrequenzschwelle
- 1 zufällige Überfrequenzschwelle (bei Bedarf aktivierbar)
- Einschaltverzögerung
- zufällige Einschaltverzögerung (bei Bedarf aktivierbar)
- Melderelais R3 - Aktivierung (LED R3 ON) bei Fehler Rückmeldekontakt

9.19 VDE-AR-N 4105:2018-11 (Umrichter)

- Auswählbarer Connection Mode (1 phasig, 3 phasig)
- Auswählbarer Rückmeldekontakt (Öffner / Schließer)
- Zusätzliche zeitliche Überwachung des Rückmeldekontaktes beim Zuschalten
- Auswählbare Fernabschaltung (Öffner / Schließer)
- 1 Überspannungsschwelle - Außenleiterspannung
- 2 Unterspannungsschwellen - Außenleiterspannung
- 1 Überspannungsschwelle - Sternspannung
- 2 Unterspannungsschwellen - Sternspannung
- 10-Minuten Mittelwert Überspannungsschwelle
- 1 Überfrequenzschwelle
- 1 Unterfrequenzschwelle
- 1 zufällige Überfrequenzschwelle (bei Bedarf aktivierbar)
- Einschaltverzögerung
- zufällige Einschaltverzögerung (bei Bedarf aktivierbar)
- Melderelais R3 - Aktivierung (LED R3 ON) bei Fehler Rückmeldekontakt

9.20 VDE-AR-N 4110:2018-11 (geprüft nach TR3, Bewertungsbericht TR8)

- Auswählbarer Connection Mode (1 phasig, 3 phasig)
- Auswählbare Nennspannung
- Auswählbarer Rückmeldekontakt (Öffner / Schließer)
- Auswählbare Fernabschaltung (Öffner / Schließer)
- 2 Überspannungsschwellen – Außenleiterspannung (autom. Auswahl abhängig von Connection Mode)
- 2 Unterspannungsschwellen – Außenleiterspannung (autom. Auswahl abhängig von Connection Mode)
- 2 Überspannungsschwelle - Sternspannung (autom. Auswahl abhängig vom Connection Mode)
- 2 Unterspannungsschwellen - Sternspannung (autom. Auswahl abhängig vom Connection Mode)
- 2 Überfrequenzschwellen
- 1 Unterfrequenzschwelle
- Einschaltverzögerung

9.21 CEI 0-21:2019

- Auswählbarer Connection Mode (1 phasig, 3 phasig)
- Auswählbarer Operational Mode (transitory mode / definitive mode)
- Auswählbarer Rückmeldekontakt (Öffner / Schließer)
- Auswählbare Fernabschaltung (Öffner / Schließer)
- 1 Überspannungsschwelle - Außenleiterspannung (autom. Auswahl abh. vom Connection Mode)
- 2 Unterspannungsschwellen - Außenleiterspannung (autom. Auswahl abh. vom Connection Mode)
- 1 Überspannungsschwelle - Sternspannung (autom. Auswahl abh. vom Connection Mode)
- 2 Unterspannungsschwellen - Sternspannung (autom. Auswahl abh. vom Connection Mode)
- 10-Minuten Mittelwert Überspannungsschwelle
- 3 umschaltbare Überfrequenzschwellen (Umschaltung über Operational Mode und digitale Inputs)
- 3 umschaltbare Unterfrequenzschwellen (Umschaltung über Operational Mode und digitale Inputs)
- 1 Frequenzrampenschwelle (RoCoF ... bei Bedarf aktivierbar), RoCoF-Window verstellbar
- Auswählbare RoCoF window length
- Einschaltverzögerung
- Melderelais R3 - Aktivierung (LED R3 ON) bei Fehler Rückmeldekontakt

9.22 G99/1/3 LV:2018 (Niederspannung)

- Auswählbare Nennspannung
- Auswählbarer Rückmeldekontakt (Öffner / Schließer)
- Auswählbare Fernabschaltung (Öffner / Schließer)
- 2 Überspannungsschwellen - Sternspannung
- 1 Unterspannungsschwelle - Sternspannung
- 1 Überfrequenzschwelle
- 2 Unterfrequenzschwellen
- 1 Frequenzrampenschwelle (RoCoF ... bei Bedarf aktivierbar)
- 1 Phasensprungschwelle (PShift ... bei Bedarf deaktivierbar)
- Einschaltverzögerung

9.23 G99/1/3 HV:2018 (Mittel/Hochspannung)

- Auswählbare Nennspannung
- Auswählbarer Rückmeldekontakt (Öffner / Schließer)
- Auswählbare Fernabschaltung (Öffner / Schließer)
- 2 Überspannungsschwellen - Außenleiterspannung
- 1 Unterspannungsschwelle - Außenleiterspannung
- 1 Überfrequenzschwelle
- 2 Unterfrequenzschwellen
- 1 Frequenzrampenschwelle (RoCoF ... bei Bedarf aktivierbar)
- 1 Phasensprungschwelle (PShift ... bei Bedarf deaktivierbar)
- Einschaltverzögerung

9.24 G98/1/2:2018 (Niederspannung)

- Auswählbare Nennspannung
- Auswählbarer Rückmeldekontakt (Öffner / Schließer)
- Auswählbare Fernabschaltung (Öffner / Schließer)
- 2 Überspannungsschwellen - Sternspannung
- 1 Unterspannungsschwelle - Sternspannung
- 1 Überfrequenzschwelle
- 2 Unterfrequenzschwellen
- 1 Frequenzrampenschwelle (RoCoF ... bei Bedarf aktivierbar)
- 1 Phasensprungschwelle (PShift ... bei Bedarf deaktivierbar)
- Einschaltverzögerung

9.25 C10-11:2021 LV-IP (Interface Protection / Niederspannung)

- Auswählbarer Connection Mode (1 phasig, 3 phasig)
- Auswählbare Nennspannung
- Auswählbarer Rückmeldekontakt (Öffner / Schließer)
- Zusätzliche zeitliche Überwachung des Rückmeldekontaktes
- Auswählbare Fernabschaltung (Öffner / Schließer)
- 2 Überspannungsschwellen - Sternspannung
- 2 Unterspannungsschwellen - Sternspannung
- 1 Überspannungsschwelle Zero Sequence
- activation narrower frequency window (anfw) bei Unterspannung
- activation narrower frequency window (anfw) bei Zero Sequence
- activation narrower frequency window (anfw) mit digital input (DI5)
- 1 Überfrequenzschwelle
- 1 Überfrequenzschwelle bei activation narrower frequency window (anfw)
- 1 Unterfrequenzschwelle
- 1 Unterfrequenzschwelle bei activation narrower frequency window (anfw)
- 1 Frequenzrampenschwelle (RoCoF ... bei Bedarf aktivierbar)
- 1 Phasensprungschwelle (PShift ... bei Bedarf deaktivierbar)
- Einschaltverzögerung
- Melderelais R3 - Aktivierung (LED R3 ON) bei Fehler Rückmeldekontakt

9.26 C10-11:2019 LV-ASS (Automatic Separation System / Niederspannung)

- Auswählbarer Connection Mode (1 phasig, 3 phasig)
- Auswählbare Nennspannung
- Auswählbarer Rückmeldekontakt (Öffner / Schließer)
- Zusätzliche zeitliche Überwachung des Rückmeldekontaktes
- Auswählbare Fernabschaltung (Öffner / Schließer)
- 1 Überspannungsschwellen - Sternspannung
- 1 Unterspannungsschwellen - Sternspannung
- 10-Minuten Mittelwert Überspannungsschwelle
- 1 Überfrequenzschwelle
- 1 Unterfrequenzschwelle
- 1 Frequenzrampenschwelle (RoCoF ... bei Bedarf aktivierbar)
- 1 Phasensprungschwelle (PShift ... bei Bedarf deaktivierbar)
- Einschaltverzögerung
- Melderelais R3 - Aktivierung (LED R3 ON) bei Fehler Rückmeldekontakt

9.27 C10-11:2021 HV-IP (Interface Protection / Hochspannung)

- Auswählbarer Connection Mode (1 phasig, 3 phasig)
- Auswählbare Nennspannung
- Auswählbarer Rückmeldekontakt (Öffner / Schließer)
- Zusätzliche zeitliche Überwachung des Rückmeldekontaktes
- Auswählbare Fernabschaltung (Öffner / Schließer)
- 2 Überspannungsschwellen - Außenleiterspannung
- 2 Unterspannungsschwellen - Außenleiterspannung
- activation narrower frequency window (anfw) bei Unterspannung
- activation narrower frequency window (anfw) mit digital input (DI5)
- 1 Überfrequenzschwelle
- 1 Überfrequenzschwelle bei activation narrower frequency window (anfw)
- 1 Unterfrequenzschwelle
- 1 Unterfrequenzschwelle bei activation narrower frequency window (anfw)
- 1 Frequenzrampenschwelle (RoCoF ... bei Bedarf aktivierbar)
- 1 Phasensprungschwelle (PShift ... bei Bedarf deaktivierbar)
- Einschaltverzögerung
- Melderelais R3 - Aktivierung (LED R3 ON) bei Fehler Rückmeldekontakt

9.28 C10-11:2019 HV-ASS (Automatic Separation System / Hochspannung)

- Auswählbarer Connection Mode (1 phasig, 3 phasig)
- Auswählbare Nennspannung
- Auswählbarer Rückmeldekontakt (Öffner / Schließer)
- Zusätzliche zeitliche Überwachung des Rückmeldekontaktes
- Auswählbare Fernabschaltung (Öffner / Schließer)
- 1 Überspannungsschwellen - Außenleiterspannung
- 1 Unterspannungsschwellen - Außenleiterspannung
- 10-Minuten Mittelwert Überspannungsschwelle
- 1 Überfrequenzschwelle
- 1 Unterfrequenzschwelle
- 1 Frequenzrampenschwelle (RoCoF ... bei Bedarf aktivierbar)
- 1 Phasensprungschwelle (PShift ... bei Bedarf deaktivierbar)
- Einschaltverzögerung
- Melderelais R3 - Aktivierung (LED R3 ON) bei Fehler Rückmeldekontakt

9.29 NA/EEA- CH 2014 Typ A <1MW (Niederspannung)

- Auswählbarer Connection Mode (1 phasig, 3 phasig)
- Auswählbare Nennspannung
- Auswählbarer Rückmeldekontakt (Öffner / Schließer)
- Auswählbare Fernabschaltung (Öffner / Schließer)
- 2 Überspannungsschwellen - Außenleiterspannung
- 1 Unterspannungsschwelle - Außenleiterspannung
- 2 Überspannungsschwellen - Sternspannung
- 1 Unterspannungsschwelle - Sternspannung
- 10-Minuten Mittelwert Überspannungsschwelle
- 1 Überfrequenzschwelle
- 1 Unterfrequenzschwelle
- Einschaltverzögerung
- Melderelais R3 - Aktivierung (LED R3 ON) bei Ansprechen einer Schutzfunktion U/f oder bei Fehler Rückmeldekontakt

9.30 NA/EEA-NE7 - CH 2020 Typ A 800W bis 250kW (Niederspannung)

- Auswählbarer Connection Mode (1 phasig, 3 phasig)
- Auswählbare Nennspannung
- Auswählbarer Rückmeldekontakt (Öffner / Schließer)
- Auswählbare Fernabschaltung (Öffner / Schließer)
- 2 Überspannungsschwellen - Außenleiterspannung
- 2 Unterspannungsschwellen - Außenleiterspannung
- 2 Überspannungsschwellen - Sternspannung
- 2 Unterspannungsschwellen - Sternspannung
- 10-Minuten Mittelwert Überspannungsschwelle
- 1 Überfrequenzschwelle
- 1 Unterfrequenzschwelle
- 1 Frequenzrampenschwelle (RoCoF ... bei Bedarf aktivierbar)
- Einschaltverzögerung
- Melderelais R3 - Aktivierung (LED R3 ON) bei Ansprechen einer Schutzfunktion U/f oder bei Fehler Rückmeldekontakt

9.31 NA/EEA-NE7 - CH 2020 Typ B 250kW bis 36MW (Niederspannung)

- Auswählbarer Connection Mode (1 phasig, 3 phasig)
- Auswählbare Nennspannung
- Auswählbarer Rückmeldekontakt (Öffner / Schließer)
- Auswählbare Fernabschaltung (Öffner / Schließer)
- 2 Überspannungsschwellen - Außenleiterspannung
- 2 Unterspannungsschwellen - Außenleiterspannung
- 2 Überspannungsschwellen - Sternspannung
- 2 Unterspannungsschwellen - Sternspannung
- 10-Minuten Mittelwert Überspannungsschwelle
- 1 Überfrequenzschwelle
- 1 Unterfrequenzschwelle
- 1 Frequenzrampenschwelle (RoCoF ... bei Bedarf aktivierbar)
- Einschaltverzögerung
- Melderelais R3 - Aktivierung (LED R3 ON) bei Ansprechen einer Schutzfunktion U/f oder bei Fehler Rückmeldekontakt

9.32 EN 50549-1:2019 LV (Niederlande)

- Auswählbarer Connection Mode (1 phasig, 3 phasig)
- Auswählbare Nennspannung
- Auswählbarer Rückmeldekontakt (Öffner / Schließer)
- Zusätzliche zeitliche Überwachung des Rückmeldekontaktes
- Auswählbare Fernabschaltung (Öffner / Schließer)
- 2 Überspannungsschwellen - Außenleiterspannung
- 2 Unterspannungsschwellen - Außenleiterspannung
- 2 Überspannungsschwellen - Sternspannung
- 2 Unterspannungsschwellen - Sternspannung
- 1 Überspannungsschwelle Zero Sequence
- 10-Minuten Mittelwert Überspannungsschwelle
- activation narrower frequency window (anfw) bei Unterspannung
- activation narrower frequency window (anfw) bei Zero Sequence
- activation narrower frequency window (anfw) mit digital input (DI5)
- 1 Überfrequenzschwelle
- 1 Überfrequenzschwelle bei activation narrower frequency window (anfw)
- 1 Unterfrequenzschwelle
- 1 Unterfrequenzschwelle bei activation narrower frequency window (anfw)
- 1 Frequenzrampenschwelle (RoCoF ... bei Bedarf aktivierbar)
- 1 Phasensprungschwelle (PShift ... bei Bedarf deaktivierbar)
- Einschaltverzögerung

9.33 EN 50549-2:2019 HV (Niederlande)

- Auswählbarer Connection Mode (1 phasig, 3 phasig)
- Auswählbare Nennspannung
- Auswählbarer Rückmeldekontakt (Öffner / Schließer)
- Zusätzliche zeitliche Überwachung des Rückmeldekontaktes
- Auswählbare Fernabschaltung (Öffner / Schließer)
- 2 Überspannungsschwellen - Außenleiterspannung
- 2 Unterspannungsschwellen - Außenleiterspannung
- 2 Überspannungsschwellen - Sternspannung
- 2 Unterspannungsschwellen - Sternspannung
- 1 Überspannungsschwelle Zero Sequence
- 10-Minuten Mittelwert Überspannungsschwelle
- activation narrower frequency window (anfw) bei Unterspannung
- activation narrower frequency window (anfw) bei Zero Sequence
- activation narrower frequency window (anfw) mit digital input (DI5)
- 1 Überfrequenzschwelle
- 1 Überfrequenzschwelle bei activation narrower frequency window (anfw)
- 1 Unterfrequenzschwelle
- 1 Unterfrequenzschwelle bei activation narrower frequency window (anfw)
- 1 Frequenzrampenschwelle (RoCoF ... bei Bedarf aktivierbar)
- 1 Phasensprungschwelle (PShift ... bei Bedarf deaktivierbar)
- Einschaltverzögerung

9.34 EN 50438:2013 (DK)

- Auswählbarer Connection Mode (1 phasig, 3 phasig)
- Auswählbare Nennspannung
- Auswählbarer Safety Mode (1 Schütz oder 2 Schütze angesteuert und überwacht)
- Auswählbarer Rückmeldekontakt (Öffner / Schließer)
- Auswählbare Fernabschaltung (Öffner / Schließer)
- 2 Überspannungsschwellen - Außenleiterspannung
- 1 Unterspannungsschwelle - Außenleiterspannung
- 2 Überspannungsschwellen - Sternspannung
- 1 Unterspannungsschwelle - Sternspannung
- 1 Überfrequenzschwelle
- 1 Unterfrequenzschwelle
- 1 Frequenzrampenschwelle (RoCoF ... bei Bedarf deaktivierbar)
- Einschaltverzögerung

9.35 VDE 0126-1-1:2013 (ERDF-NOI-RES_13E Frankreich)

- Auswählbarer Rückmeldekontakt (Öffner / Schließer)
- Auswählbare Fernabschaltung (Öffner / Schließer)
- 1 Überspannungsschwelle - Außenleiterspannung
- 1 Unterspannungsschwelle - Außenleiterspannung
- 1 Überspannungsschwelle - Sternspannung
- 1 Unterspannungsschwelle - Sternspannung
- 10-Minuten Mittelwert Überspannungsschwelle
- 1 Überfrequenzschwelle
- 1 Unterfrequenzschwelle
- 1 zufällige Überfrequenzschwelle (bei Bedarf aktivierbar)
- Einschaltverzögerung
- zufällige Einschaltverzögerung (bei Bedarf aktivierbar)

9.36 AB AS 4777.2:2020

- Auswählbarer Connection Mode (1 phasig, 3 phasig)
- Auswählbare Nennspannung
- Auswählbarer Rückmeldekontakt (Öffner / Schließer/ kein)
- Auswählbare Fernabschaltung (Öffner / Schließer)
- 2 Überspannungsschwellen - Sternspannung
- 2 Unterspannungsschwellen - Sternspannung
- 10-Minuten Mittelwert Überspannungsschwelle
- 1 Überfrequenzschwelle
- 1 Unterfrequenzschwelle
- 1 Frequenzrampenschwelle (RoCoF ... bei Bedarf aktivierbar)
- Auswählbare RoCoF window length
- 1 Phasensprungschwelle (PShift ... bei Bedarf aktivierbar)
- Auswählbare Pshift window length
- Einschaltverzögerung
- Melderelais R3 - Aktivierung (LED R3 ON) bei Ansprechen einer Schutzfunktion U/f oder bei Fehler Rückmeldekontakt

9.37 C AS 4777.2:2020

- Auswählbarer Connection Mode (1 phasig, 3 phasig)
- Auswählbare Nennspannung
- Auswählbarer Rückmeldekontakt (Öffner / Schließer/ kein)
- Auswählbare Fernabschaltung (Öffner / Schließer)
- 2 Überspannungsschwellen - Sternspannung
- 2 Unterspannungsschwellen – Sternspannung
- 10-Minuten Mittelwert Überspannungsschwelle
- 1 Überfrequenzschwelle
- 1 Unterfrequenzschwelle
- 1 Frequenzrampenschwelle (RoCoF ... bei Bedarf aktivierbar)
- Auswählbare RoCoF window length
- 1 Phasensprungschwelle (PShift ... bei Bedarf aktivierbar)
- Auswählbare Pshift window length
- Einschaltverzögerung
- Melderelais R3 - Aktivierung (LED R3 ON) bei Ansprechen einer Schutzfunktion U/f oder bei Fehler Rückmeldekontakt

9.38 NZS 4777.2:2020

- Auswählbarer Connection Mode (1 phasig, 3 phasig)
- Auswählbare Nennspannung
- Auswählbarer Rückmeldekontakt (Öffner / Schließer/ kein)
- Auswählbare Fernabschaltung (Öffner / Schließer)
- 2 Überspannungsschwellen - Sternspannung
- 2 Unterspannungsschwellen – Sternspannung
- 10-Minuten Mittelwert Überspannungsschwelle
- 1 Überfrequenzschwelle
- 1 Unterfrequenzschwelle
- 1 Frequenzrampenschwelle (RoCoF ... bei Bedarf aktivierbar)
- Auswählbare RoCoF window length
- 1 Phasensprungschwelle (PShift ... bei Bedarf aktivierbar)
- Auswählbare Pshift window length
- Einschaltverzögerung
- Melderelais R3 - Aktivierung (LED R3 ON) bei Ansprechen einer Schutzfunktion U/f oder bei Fehler Rückmeldekontakt

9.39 NRS 097-2-1:2017

- Auswählbarer Connection Mode (1 phasig, 3 phasig)
- Auswählbare Nennspannung
- Auswählbarer Rückmeldekontakt (Öffner / Schließer)
- Auswählbare Fernabschaltung (Öffner / Schließer)
- 2 Überspannungsschwelle - Außenleiterspannung (autom. Auswahl abhängig vom Connection Mode)
- 2 Unterspannungsschwellen - Außenleiterspannung (autom. Auswahl abhängig vom Connection Mode)
- 2 Überspannungsschwelle - Sternspannung (autom. Auswahl abhängig vom Connection Mode)
- 2 Unterspannungsschwellen - Sternspannung (autom. Auswahl abhängig vom Connection Mode)
- 1 Überfrequenzschwelle
- 1 Unterfrequenzschwelle
- 1 zufällige Überfrequenzschwelle (bei Bedarf aktivierbar)
- 1 Frequenzrampenschwelle (RoCoF ... bei Bedarf aktivierbar)
- 1 Phasensprungschwelle (PShift ... bei Bedarf aktivierbar)
- Einschaltverzögerung
- zufällige Einschaltverzögerung (bei Bedarf aktivierbar)
- Melderelais R3 - Aktivierung (LED R3 ON) bei Ansprechen einer Schutzfunktion U/f oder bei Fehler Rückmeldekontakt

9.40 OPEN SETUP

- Auswählbarer Connection Mode (1 phasig, 3 phasig)
- Auswählbare Nennspannung
- Auswählbarer Safety Mode (1 Schütz oder 2 Schütze angesteuert und überwacht)
- Auswählbarer Rückmeldekontakt (Öffner / Schließer)
- Auswählbare Fernabschaltung (Öffner / Schließer)
- 2 Überspannungsschwellen - Außenleiterspannung (automatische Auswahl abhängig vom Connection Mode, bei Bedarf manuell deaktivierbar)
- 2 Unterspannungsschwellen - Außenleiterspannung (automatische Auswahl abhängig vom Connection Mode, bei Bedarf manuell deaktivierbar)
- 2 Überspannungsschwellen - Sternspannung (automatische Auswahl abhängig vom Connection Mode, bei Bedarf manuell deaktivierbar)
- 2 Unterspannungsschwellen - Sternspannung (automatische Auswahl abhängig vom Connection Mode, bei Bedarf manuell deaktivierbar)
- 1 Überspannungsschwelle Zero Sequence Component (nur in Connection Mode 4-wire (LN+LL))
- 10-Minuten Mittelwert Überspannungsschwelle (bei Bedarf manuell deaktivierbar)
- 2 Überfrequenzschwellen (bei Bedarf manuell deaktivierbar)
- 2 Unterfrequenzschwelle (bei Bedarf manuell deaktivierbar)
- 1 Überfrequenzschwelle für narrower frequency window aktivierbar (NAFW) (nur in Connection Mode 4-wire (LN+LL))
- 1 Unterfrequenzschwelle für narrower frequency window aktivierbar (NAFW) (nur in Connection Mode 4-wire (LN+LL))
- Auswählbare Frequenz window length
- 1 zufällige Überfrequenzschwelle (bei Bedarf aktivierbar)
- 1 Frequenzrampenschwelle (RoCoF ... bei Bedarf aktivierbar)
- Auswählbare RoCoF window length
- 1 Phasensprungschwelle (PShift ... bei Bedarf aktivierbar)
- Auswählbare Pshift window length
- Einschaltverzögerung
- zufällige Einschaltverzögerung (bei Bedarf aktivierbar)
- Melderelais R3 - Aktivierung (LED R3 ON) bei Fehler Rückmeldekontakt und Spannungs/Frequenzfehlern
- Auswählbare Deaktivierung der Frequenzschwellen bei Unterspannung

9.41 EN 50438:2013

- Auswählbare Nennspannung
- Auswählbarer Rückmeldekontakt (Öffner / Schließer)
- Auswählbare Fernabschaltung (Öffner / Schließer)
- 1 Überspannungsschwelle - Sternspannung
- 1 Unterspannungsschwelle - Sternspannung
- 10-Minuten Mittelwert Überspannungsschwelle
- 1 Überfrequenzschwelle
- 1 Unterfrequenzschwelle
- Einschaltverzögerung

9.42 E 8001/8101 (Vorgänger von OVE TOR R25)

- Auswählbarer Connection Mode (1 phasig, 3 phasig)
- Auswählbare Nennspannung
- Auswählbarer Rückmeldekontakt (Öffner / Schließer)
- Auswählbare Fernabschaltung (Öffner / Schließer)
- 2 Überspannungsschwellen - Außenleiterspannung
- 2 Unterspannungsschwellen - Außenleiterspannung
- 2 Überspannungsschwellen - Sternspannung
- 2 Unterspannungsschwellen - Sternspannung
- 10-Minuten Mittelwert Überspannungsschwelle
- 1 Überfrequenzschwelle
- 1 Unterfrequenzschwelle
- Einschaltverzögerung

9.43 VDE 0124-100:2013 (Vorgänger von VDE-AR-N 4105:2018-11)

- Auswählbarer Rückmeldekontakt (Öffner / Schließer)
- Auswählbare Fernabschaltung (Öffner / Schließer)
- 1 Überspannungsschwelle - Außenleiterspannung
- 1 Unterspannungsschwelle - Außenleiterspannung
- 1 Überspannungsschwelle - Sternspannung
- 1 Unterspannungsschwelle - Sternspannung
- 10-Minuten Mittelwert Überspannungsschwelle
- 1 Überfrequenzschwelle
- 1 Unterfrequenzschwelle
- 1 zufällige Überfrequenzschwelle (bei Bedarf aktivierbar)
- Einschaltverzögerung
- zufällige Einschaltverzögerung (bei Bedarf aktivierbar)

9.44 TR3 Rev23:2013 (Vorgänger von VDE-AR-N 4110:2018-11)

- Auswählbarer Connection Mode (1 phasig, 3 phasig)
- Auswählbare Nennspannung
- Auswählbarer Rückmeldekontakt (Öffner / Schließer)
- Auswählbare Fernabschaltung (Öffner / Schließer)
- 1 Überspannungsschwelle – Außenleiterspannung (autom. Auswahl abhängig vom Connection Mode)
- 2 Unterspannungsschwellen – Außenleiterspannung (autom. Auswahl abhängig vom Connection Mode)
- 1 Überspannungsschwelle - Sternspannung (autom. Auswahl abhängig vom Connection Mode)
- 2 Unterspannungsschwellen - Sternspannung (autom. Auswahl abhängig vom Connection Mode)
- 1 Überfrequenzschwelle
- 1 Unterfrequenzschwelle
- Einschaltverzögerung

9.45 AS/NZS 4777.2:2015 (Niederspannung)

- Local standards must be taken into account
- Auswählbarer Connection Mode (1 phasig, 3 phasig)
- Auswählbare Nennspannung
- Auswählbarer Rückmeldekontakt (Öffner / Schließer/ kein)
- Auswählbare Fernabschaltung (Öffner / Schließer)
- 2 Überspannungsschwellen - Sternspannung
- 1 Unterspannungsschwelle - Sternspannung
- 1 Überfrequenzschwelle
- 1 Unterfrequenzschwelle
- 10-Minuten Mittelwert Überspannungsschwelle
- 1 Frequenzrampenschwelle (RoCoF ... bei Bedarf deaktivierbar)
- Auswählbare RoCoF window length
- 1 Phasensprungschwelle (PShift ... bei Bedarf deaktivierbar)
- Auswählbare Pshift window length
- Einschaltverzögerung
- Melderelais R3 - Aktivierung (LED R3 ON) bei Ansprechen einer Schutzfunktion U/f oder bei Fehler Rückmeldekontakt

9.46 G59/3/3:2015 LV (Niederspannung – Vorgänger von G99/1/3 LV:2018)

- Auswählbare Nennspannung
- Auswählbarer Rückmeldekontakt (Öffner / Schließer)
- Auswählbare Fernabschaltung (Öffner / Schließer)
- 2 Überspannungsschwellen - Sternspannung
- 2 Unterspannungsschwellen - Sternspannung
- 2 Überfrequenzschwellen
- 2 Unterfrequenzschwellen
- 1 Frequenzrampenschwelle (RoCoF ... bei Bedarf deaktivierbar)
- 1 Phasensprungschwelle (PShift ... bei Bedarf aktivierbar)
- Einschaltverzögerung

9.47 G59/3/3:2015 MV (Mittelspannung Vorgänger von G99/1/3 HV:2018)

- Auswählbare Nennspannung
- Auswählbarer Rückmeldekontakt (Öffner / Schließer)
- Auswählbare Fernabschaltung (Öffner / Schließer)
- 2 Überspannungsschwellen - Außenleiterspannung
- 2 Unterspannungsschwellen - Außenleiterspannung
- 2 Überfrequenzschwellen
- 2 Unterfrequenzschwellen
- 1 Frequenzrampenschwelle (RoCoF ... bei Bedarf deaktivierbar)
- 1 Phasensprungschwelle (PShift ... bei Bedarf aktivierbar)
- Einschaltverzögerung

9.48 G83/2:2012 (Niederspannung Vorgänger von G98/1/2:2018)

- Auswählbare Nennspannung
- Auswählbarer Rückmeldekontakt (Öffner / Schließer)
- Auswählbare Fernabschaltung (Öffner / Schließer)
- 2 Überspannungsschwellen - Sternspannung
- 2 Unterspannungsschwellen - Sternspannung
- 2 Überfrequenzschwellen
- 2 Unterfrequenzschwellen
- 1 Frequenzrampenschwelle (RoCoF ... bei Bedarf aktivierbar)
- 1 Phasensprungschwelle (PShift ... bei Bedarf deaktivierbar)
- Einschaltverzögerung

9.49 C10-11:2012 LV (Niederspannung Vorgänger von C10-11:2019)

- Auswählbarer Connection Mode (1 phasig, 3 phasig)
- Auswählbare Nennspannung
- Auswählbarer Rückmeldekontakt (Öffner / Schließer)
- Auswählbare Fernabschaltung (Öffner / Schließer)
- 1 Überspannungsschwelle - Sternspannung
- 2 Unterspannungsschwellen - Sternspannung
- 1 Überfrequenzschwelle
- 1 Unterfrequenzschwelle
- 1 Frequenzrampenschwelle (RoCoF ... bei Bedarf aktivierbar)
- 1 Phasensprungschwelle (PShift ... bei Bedarf deaktivierbar)
- Einschaltverzögerung

9.50 C10-11:2012 MV (Mittelspannung Vorgänger von C10-11:2019)

- Auswählbarer Connection Mode (1 phasig, 3 phasig)
- Auswählbare Nennspannung
- Auswählbarer Rückmeldekontakt (Öffner / Schließer)
- Auswählbare Fernabschaltung (Öffner / Schließer)
- 1 Überspannungsschwelle - Außenleiterspannung
- 2 Unterspannungsschwellen - Außenleiterspannung
- 1 Überfrequenzschwelle
- 1 Unterfrequenzschwelle
- 1 Frequenzrampenschwelle (RoCoF ... bei Bedarf aktivierbar)
- 1 Phasensprungschwelle (PShift ... bei Bedarf deaktivierbar)
- Einschaltverzögerung

9.51 C10-11:2019 LV-IP (Interface Protection / Niederspannung Vorgänger von C10-11:2021)

- Auswählbarer Connection Mode (1 phasig, 3 phasig)
- Auswählbare Nennspannung
- Auswählbarer Rückmeldekontakt (Öffner / Schließer)
- Zusätzliche zeitliche Überwachung des Rückmeldekontaktes
- Auswählbare Fernabschaltung (Öffner / Schließer)
- 2 Überspannungsschwellen - Sternspannung
- 2 Unterspannungsschwellen - Sternspannung
- 1 Überfrequenzschwelle
- 1 Unterfrequenzschwelle
- 1 Frequenzrampenschwelle (RoCoF ... bei Bedarf aktivierbar)
- 1 Phasensprungschwelle (PShift ... bei Bedarf deaktivierbar)
- Einschaltverzögerung
- Melderelais R3 - Aktivierung (LED R3 ON) bei Fehler Rückmeldekontakt

9.52 C10-11:2019 HV-IP (Interface Protection / Hochspannung Vorgänger von C10-11:2021)

- Auswählbarer Connection Mode (1 phasig, 3 phasig)
- Auswählbare Nennspannung
- Auswählbarer Rückmeldekontakt (Öffner / Schließer)
- Zusätzliche zeitliche Überwachung des Rückmeldekontaktes
- Auswählbare Fernabschaltung (Öffner / Schließer)
- 2 Überspannungsschwellen - Außenleiterspannung
- 2 Unterspannungsschwellen - Außenleiterspannung
- 1 Überfrequenzschwelle
- 1 Unterfrequenzschwelle
- 1 Frequenzrampenschwelle (RoCoF ... bei Bedarf aktivierbar)
- 1 Phasensprungschwelle (PShift ... bei Bedarf deaktivierbar)
- Einschaltverzögerung
- Melderelais R3 - Aktivierung (LED R3 ON) bei Fehler Rückmeldekontakt

10 ANHANG (Parameter der implementierten Standards im Detail)

10.1 ÖVE TOR R25 NS SYNC [ID 802] Typ A/B low voltage synchr. generators

Connection Mode			Conformity Range		Possible Range	
ID		Default				
.003	Connection	4-wire (LN)	4-wire (LN)		2-wire, 3-wire, 4-wire (LN), 4-wire (LN+LL)	

Nominal Voltage				Conformity Range		Possible Range		
ID				Default	Min	Max	Min	Max
.005	ULN/LL nom	Unom Y	V	230.0	57.5	230.0	28.8	241.4
		Unom Δ	V	400.0	100.0	400.0	50.0	420.0

Functional Safety			Conformity Range		Possible Range	
ID		Default				
.007	Errtol	Fixed to 2ch				
Remark:		2ch means: 2 channel with functional safety and 2 auxilliary contacts necessary				

Overvoltage1 Line to Neutral				Conformity Range		Possible Range		
ID				Default	Min	Max	Min	Max
.018	Ueff >	Enable function		on	on / off		on / off	
.019	Ueff > off	U _{THR} OFF	%Unom	111	100	130	100	135
.020	Ueff > on	U _{THR} ON	%Unom	108	100	108	100	135
.021	T Ueff >	Time OFF	ms	60000	50	180000	50	180000
Comment:		Ueff > on has a fixed offset of 0.5% U _{NOM} subtracted from the displayed value						
Only active for:		Connection Modes: 2-wire, 4-wire (LN), 4-wire (LN+LL)						

Undervoltage1 Line to Neutral				Conformity Range		Possible Range		
ID				Default	Min	Max	Min	Max
.023	Ueff < off	U _{THR} OFF	%Unom	80	10	100	10	100
.024	Ueff < on	U _{THR} ON	%Unom	90	86	100	10	100
.025	T Ueff <	Time OFF	ms	1000	50	180000	50	180000
Comment:		Ueff < on has a fixed offset of 0.5% U _{NOM} added to the displayed value						
Only active for:		Connection Modes: 2-wire, 4-wire (LN), 4-wire (LN+LL)						

Overvoltage2 Line to Neutral				Conformity Range		Possible Range		
ID				Default	Min	Max	Min	Max
.034	Ueff>>	Enable function		on	on		on / off	
.035	Ueff>> off	U _{THR} OFF	%Unom	115	100	130	100	135
.036	Ueff>> on	U _{THR} ON	%Unom	108	100	108	100	135
.037	T Ueff>>	Time OFF	ms	100	50	180000	50	180000
Comment:		Ueff>> on has a fixed offset of 0.5% U _{NOM} subtracted from the displayed value						
Only active for:		Connection Modes: 2-wire, 4-wire (LN), 4-wire (LN+LL)						

Undervoltage2 Line to Neutral				Conformity Range		Possible Range		
ID				Default	Min	Max	Min	Max
.038	Ueff<<	Enable function		on	on		on / off	
.039	Ueff<< off	U _{THR} OFF	%Unom	30	10	100	10	100
.040	Ueff<< on	U _{THR} ON	%Unom	90	86	100	0	100
.041	T Ueff<<	Time OFF	ms	200	50	180000	50	180000
Comment:		Ueff<< on has a fixed offset of 0.5% U _{NOM} added to the displayed value						
Only active for:		Connection Modes: 2-wire, 4-wire (LN), 4-wire (LN+LL)						

10 minutes average overvoltage				Conformity Range		Possible Range		
ID				Default	Min	Max	Min	Max
.042	U10min	Enable function		off	on / off		on /off	
.043	U10min off	U _{THR} OFF	%Unom	111	100	130	100	135
		U _{THR} ON	%Unom	Fixed Hysteresis (0.9% U _{NOM})				
		Time OFF	ms	Fixed to fastest possible disconnection				

Overfrequency1				Conformity Range		Possible Range		
ID				Default	Min	Max	Min	Max
.055	f > off	f _{THR} OFF	Hz	51.50	50.00	55.00	50.00	55.00
.056	f > on	f _{THR} ON	Hz	50.05	50.00	50.05	50.00	55.00
.057	T f >	Time OFF	ms	50	50	50	50	180000
Comment:		f > on has a fixed offset of 0.01 Hz subtracted to the displayed value						
Only active for:		Voltage > 60% U _{NOM}						

Underfrequency1				Conformity Range		Possible Range		
ID				Default	Min	Max	Min	Max
.059	f < off	f _{THR} OFF	Hz	47.50	45.00	50.00	45.00	50.00
.060	f < on	f _{THR} ON	Hz	49.50	47.55	50.00	45.00	50.00
.061	T f <	Time OFF	ms	50	50	50	50	180000
Comment:		f < on has a fixed offset of 0.01 Hz added to the displayed value						
Only active for:		Voltage > 60% U _{NOM}						

Frequency measuring in general				Conformity Range		Possible Range		
ID				Default	Min	Max	Min	Max
.113	F wnd	Window length	ms	Fixed window length 100ms				

Auxiliary Contact type				Conformity Range		Possible Range		
ID				Default	Min	Max	Min	Max
.099	Contact	Type	n.c. (normally closed)		n.o. (normally opened) n.c. (normally closed)		n.o. (normally opened) n.c. (normally closed) dis. (disabled)	
.100	T Contact	Time OFF	ms	Fixed to 500ms				
.114	I3 STOP	Type	n.o. (normally opened)		n.o. (normally opened) n.c. (normally closed) dis. (disabled)		n.o. (normally opened) n.c. (normally closed) dis. (disabled)	

Turn-on delay				Conformity Range		Possible Range		
ID				Default	Min	Max	Min	Max
.102	Ton delay	Turn on time	s	60	0	300	0	600

Password							
ID				Default	Min	Max	
.106	PW1	1 st digit of Password		0	0	9	
.107	PW2	2 nd digit of Password		0	0	9	
.108	PW3	3 rd digit of Password		0	0	9	
.109	PW4	4 th digit of Password		0	0	9	
Remark:		If all 4 digits of the Password are 0 (default setting) the Password request is skipped					

Device Information		
ID		
.105	ID: xxxxxx SW: aa.dd.ccb	xxxxx = Device ID dd: Software version of Display Software aa: Software version of Measuring Software cc: Index of Configuration set b: Version of Configuration set

10.2 ÖVE TOR R25 NS ASYNC [ID 803] Typ A/B low voltage asynchr. generators

Connection Mode			Conformity Range		Possible Range	
ID		Default				
.003	Connection	4-wire (LN)	4-wire (LN)		2-wire, 3-wire, 4-wire (LN), 4-wire (LN+LL)	

Nominal Voltage				Conformity Range		Possible Range		
ID		Default		Min	Max	Min	Max	
.005	ULN/LL nom	Unom Y	V	230.0	57.5	230.0	28.8	241.4
		Unom Δ	V	400.0	100.0	400.0	50.0	420.0

Functional Safety			Conformity Range		Possible Range	
ID		Default				
.007	Errtol	Fixed to 2ch				
Remark:		2ch means: 2 channel with functional safety and 2 auxilliary contacts necessary				

Overvoltage1 Line to Neutral				Conformity Range		Possible Range		
ID		Default		Min	Max	Min	Max	
.018	Ueff >	Enable function		on		on / off		
.019	Ueff > off	U _{THR} OFF	%Unom	111	100	130	100	135
.020	Ueff > on	U _{THR} ON	%Unom	108	100	108	100	135
.021	T Ueff >	Time OFF	ms	60000	50	180000	50	180000
Comment:		Ueff > on has a fixed offset of 0.5% U _{NOM} subtracted from the displayed value						
Only active for:		Connection Modes: 2-wire, 4-wire (LN), 4-wire (LN+LL)						

Undervoltage1 Line to Neutral				Conformity Range		Possible Range		
ID		Default		Min	Max	Min	Max	
.023	Ueff < off	U _{THR} OFF	%Unom	80	10	100	10	100
.024	Ueff < on	U _{THR} ON	%Unom	90	86	100	10	100
.025	T Ueff <	Time OFF	ms	1500	50	180000	50	180000
Comment:		Ueff < on has a fixed offset of 0.5% U _{NOM} added to the displayed value						
Only active for:		Connection Modes: 2-wire, 4-wire (LN), 4-wire (LN+LL)						

Overvoltage2 Line to Neutral				Conformity Range		Possible Range		
ID		Default		Min	Max	Min	Max	
.034	Ueff>>	Enable function		on		on / off		
.035	Ueff>> off	U _{THR} OFF	%Unom	115	100	130	100	135
.036	Ueff>> on	U _{THR} ON	%Unom	108	100	108	100	135
.037	T Ueff>>	Time OFF	ms	100	50	180000	50	180000
Comment:		Ueff>> on has a fixed offset of 0.5% U _{NOM} subtracted from the displayed value						
Only active for:		Connection Modes: 2-wire, 4-wire (LN), 4-wire (LN+LL)						

Undervoltage2 Line to Neutral				Conformity Range		Possible Range		
ID		Default		Min	Max	Min	Max	
.038	Ueff<<	Enable function		on		on / off		
.039	Ueff<< off	U _{THR} OFF	%Unom	25	10	100	10	100
.040	Ueff<< on	U _{THR} ON	%Unom	90	86	100	0	100
.041	T Ueff<<	Time OFF	ms	500	50	180000	50	180000
Comment:		Ueff<< on has a fixed offset of 0.5% U _{NOM} added to the displayed value						
Only active for:		Connection Modes: 2-wire, 4-wire (LN), 4-wire (LN+LL)						

10 minutes average overvoltage				Conformity Range		Possible Range		
ID				Default	Min	Max	Min	Max
.042	U10min	Enable function		off	on / off		on /off	
.043	U10min off	U _{THR} OFF	%Unom	111	100	130	100	135
		U _{THR} ON	%Unom	Fixed Hysteresis (0.9% U _{NOM})				
		Time OFF	ms	Fixed to fastest possible disconnection				

Overfrequency1				Conformity Range		Possible Range		
ID				Default	Min	Max	Min	Max
.055	f > off	f _{THR} OFF	Hz	51.50	50.00	55.00	50.00	55.00
.056	f > on	f _{THR} ON	Hz	50.05	50.00	50.05	50.00	55.00
.057	T f >	Time OFF	ms	50	50	50	50	180000
Comment:		f > on has a fixed offset of 0.01 Hz subtracted to the displayed value						
Only active for:		Voltage > 60% U _{NOM}						

Underfrequency1				Conformity Range		Possible Range		
ID				Default	Min	Max	Min	Max
.059	f < off	f _{THR} OFF	Hz	47.50	45.00	50.00	45.00	50.00
.060	f < on	f _{THR} ON	Hz	49.50	47.55	50.00	45.00	50.00
.061	T f <	Time OFF	ms	50	50	50	50	180000
Comment:		f < on has a fixed offset of 0.01 Hz added to the displayed value						
Only active for:		Voltage > 60% U _{NOM}						

Frequency measuring in general				Conformity Range		Possible Range		
ID				Default	Min	Max	Min	Max
.113	F wnd	Window length	ms	Fixed window length 100ms				

Auxiliary Contact type				Conformity Range		Possible Range		
ID				Default	Min	Max	Min	Max
.099	Contact	Type	n.c. (normally closed)		n.o. (normally opened) n.c. (normally closed)		n.o. (normally opened) n.c. (normally closed) dis. (disabled)	
.100	T Contact	Time OFF	ms	Fixed to 500ms				
.114	I3 STOP	Type	n.o. (normally opened)		n.o. (normally opened) n.c. (normally closed) dis. (disabled)		n.o. (normally opened) n.c. (normally closed) dis. (disabled)	

Turn-on delay				Conformity Range		Possible Range		
ID				Default	Min	Max	Min	Max
.102	Ton delay	Turn on time	s	60	0	300	0	600

Password						
ID				Default	Min	Max
.106	PW1	1 st digit of Password		0	0	9
.107	PW2	2 nd digit of Password		0	0	9
.108	PW3	3 rd digit of Password		0	0	9
.109	PW4	4 th digit of Password		0	0	9
Remark:		If all 4 digits of the Password are 0 (default setting) the Password request is skipped				

Device Information		
ID		
.105	ID: xxxxxx SW: aa.dd.ccb	xxxxx = Device ID dd: Software version of Display Software aa: Software version of Measuring Software cc: Index of Configuration set b: Version of Configuration set

10.3 ÖVE TOR R25 MS SYNC [ID 852] Typ A/B medium voltage synchr. generators

Connection Mode			Conformity Range		Possible Range	
ID		Default				
.003	Connection	3-wire	3-wire		2-wire, 3-wire, 4-wire (LN), 4-wire (LN+LL)	

Nominal Voltage				Conformity Range		Possible Range		
ID		Default		Min	Max	Min	Max	
.005	ULN/LL nom	Unom Y	V	60.4	57.5	230.0	28.8	241.4
		Unom Δ	V	105.0	100.0	400.0	50.0	420.0
Comment:		Default for Uc=21kV and 200:1 voltage transformer or Uc=31,7kV and 300:1						

Functional Safety			Conformity Range		Possible Range	
ID		Default				
.007	Errtol	Fixed to 2ch				
Remark:		2ch means: 2 channel with functional safety and 2 auxilliary contacts necessary				

Overvoltage1 Line to Line				Conformity Range		Possible Range		
ID		Default		Min	Max	Min	Max	
.011	U > off	U _{THR} OFF	%Unom	106	100	130	100	135
.012	U > on	U _{THR} ON	%Unom	104	100	108	100	135
.013	T U >	Time OFF	ms	60000	50	180000	50	180000
Comment:		U > on has a fixed offset of 0.5% U _{NOM} subtracted from the displayed value						
Only active for:		Connection Modes: 3-wire, 4-wire (LN+LL)						

Undervoltage1 Line to Line				Conformity Range		Possible Range		
ID		Default		Min	Max	Min	Max	
.015	U < off	U _{THR} OFF	%Unom	70	10	100	10	100
.016	U < on	U _{THR} ON	%Unom	90	86	100	10	100
.017	T U <	Time OFF	ms	1500	50	180000	50	180000
Comment:		U < on has a fixed offset of 0.5% U _{NOM} added to the displayed value						
Only active for:		Connection Modes: 3-wire, 4-wire (LN+LL)						

Overvoltage2 Line to Line				Conformity Range		Possible Range		
ID		Default		Min	Max	Min	Max	
.026	U >>	Enable function		on	on	on /off		
.027	U >> off	U _{THR} OFF	%Unom	110	100	130	100	135
.028	U >> on	U _{THR} ON	%Unom	104	100	108	100	135
.029	T U >>	Time OFF	ms	100	50	180000	50	180000
Comment:		U >> on has a fixed offset of 0.5% U _{NOM} subtracted from the displayed value						
Only active for:		Connection Modes: 3-wire, 4-wire (LN+LL)						

Undervoltage2 Line to Line				Conformity Range		Possible Range		
ID		Default		Min	Max	Min	Max	
.030	U <<	Enable function		on	on	on /off		
.031	U << off	U _{THR} OFF	%Unom	30	10	100	10	100
.032	U << on	U _{THR} ON	%Unom	90	86	100	0	100
.033	T U <<	Time OFF	ms	700	50	180000	50	180000
Comment:		U << on has a fixed offset of 0.5% U _{NOM} added to the displayed value						
Only active for:		Connection Modes: 3-wire, 4-wire (LN+LL)						

Overfrequency1					Conformity Range		Possible Range	
ID				Default	Min	Max	Min	Max
.055	f > off	f _{THR} OFF	Hz	51.50	50.00	55.00	50.00	55.00
.056	f > on	f _{THR} ON	Hz	50.05	50.00	50.05	50.00	55.00
.057	T f >	Time OFF	ms	50	50	50	50	180000
Comment:		f > on has a fixed offset of 0.01 Hz subtracted to the displayed value						
Only active for:		Voltage > 60% U _{NOM}						

Underfrequency1					Conformity Range		Possible Range	
ID				Default	Min	Max	Min	Max
.059	f < off	f _{THR} OFF	Hz	47.50	45.00	50.00	45.00	50.00
.060	f < on	f _{THR} ON	Hz	49.50	47.55	50.00	45.00	50.00
.061	T f <	Time OFF	ms	50	50	50	50	180000
Comment:		f < on has a fixed offset of 0.01 Hz added to the displayed value						
Only active for:		Voltage > 60% U _{NOM}						

Frequency measuring in general					Conformity Range		Possible Range	
ID				Default	Min	Max	Min	Max
.113	F wnd	Window length	ms	Fixed window length 100ms				

Auxiliary Contact type					Conformity Range		Possible Range	
ID				Default	Min	Max	Min	Max
.099	Contact	Type	n.c. (normally closed)		n.o. (normally opened) n.c. (normally closed)		n.o. (normally opened) n.c. (normally closed) dis. (disabled)	
.100	T Contact	Time OFF	ms	Fixed to 500ms				
.114	I3 STOP	Type	n.o. (normally opened)		n.o. (normally opened) n.c. (normally closed) dis. (disabled)		n.o. (normally opened) n.c. (normally closed) dis. (disabled)	

Turn-on delay					Conformity Range		Possible Range	
ID				Default	Min	Max	Min	Max
.102	Ton delay	Turn on time	s	60	0	300	0	600

Password					Default	Min	Max
ID							
.106	PW1	1 st digit of Password			0	0	9
.107	PW2	2 nd digit of Password			0	0	9
.108	PW3	3 rd digit of Password			0	0	9
.109	PW4	4 th digit of Password			0	0	9
Remark:		If all 4 digits of the Password are 0 (default setting) the Password request is skipped					

Device Information		
ID		
.105	ID: xxxxxx	xxxxx = Device ID
	SW: aa.dd.ccb	dd: Software version of Display Software aa: Software version of Measuring Software cc: Index of Configuration set b: Version of Configuration set

10.4 ÖVE TOR R25 MS ASYNC [ID 853] Typ A/B medium voltage asynchr. generators

Connection Mode			Conformity Range	Possible Range
ID		Default		
.003	Connection	3-wire	3-wire	2-wire, 3-wire, 4-wire (LN), 4-wire (LN+LL)

Nominal Voltage				Conformity Range		Possible Range		
ID		Default		Min	Max	Min	Max	
.005	ULN/LL nom	Unom Y	V	60.4	57.5	230.0	28.8	241.4
		Unom Δ	V	105.0	100.0	400.0	50.0	420.0
Comment:		Default for Uc=21kV and 200:1 voltage transformer or Uc=31,7kV and 300:1						

Functional Safety			Conformity Range	Possible Range
ID		Default		
.007	Errtol	Fixed to 2ch		
Remark:		2ch means: 2 channel with functional safety and 2 auxilliary contacts necessary		

Overvoltage1 Line to Line				Conformity Range		Possible Range		
ID		Default		Min	Max	Min	Max	
.011	U > off	U _{THR} OFF	%Unom	106	100	130	100	135
.012	U > on	U _{THR} ON	%Unom	104	100	108	100	135
.013	T U >	Time OFF	ms	60000	50	180000	50	180000
Comment:		U > on has a fixed offset of 0.5% U _{NOM} subtracted from the displayed value						
Only active for:		Connection Modes: 3-wire, 4-wire (LN+LL)						

Undervoltage1 Line to Line				Conformity Range		Possible Range		
ID		Default		Min	Max	Min	Max	
.015	U < off	U _{THR} OFF	%Unom	80	10	100	10	100
.016	U < on	U _{THR} ON	%Unom	90	86	100	10	100
.017	T U <	Time OFF	ms	1500	50	180000	50	180000
Comment:		U < on has a fixed offset of 0.5% U _{NOM} added to the displayed value						
Only active for:		Connection Modes: 3-wire, 4-wire (LN+LL)						

Overvoltage2 Line to Line				Conformity Range		Possible Range		
ID		Default		Min	Max	Min	Max	
.026	U >>	Enable function		on	on	on /off		
.027	U >> off	U _{THR} OFF	%Unom	110	100	130	100	135
.028	U >> on	U _{THR} ON	%Unom	104	100	108	100	135
.029	T U >>	Time OFF	ms	100	50	180000	50	180000
Comment:		U >> on has a fixed offset of 0.5% U _{NOM} subtracted from the displayed value						
Only active for:		Connection Modes: 3-wire, 4-wire (LN+LL)						

Undervoltage2 Line to Line				Conformity Range		Possible Range		
ID		Default		Min	Max	Min	Max	
.030	U <<	Enable function		on	on	on /off		
.031	U << off	U _{THR} OFF	%Unom	30	10	100	10	100
.032	U << on	U _{THR} ON	%Unom	90	86	100	0	100
.033	T U <<	Time OFF	ms	700	50	180000	50	180000
Comment:		U << on has a fixed offset of 0.5% U _{NOM} added to the displayed value						
Only active for:		Connection Modes: 3-wire, 4-wire (LN+LL)						

Overfrequency1					Conformity Range		Possible Range	
ID				Default	Min	Max	Min	Max
.055	f > off	f _{THR} OFF	Hz	51.50	50.00	55.00	50.00	55.00
.056	f > on	f _{THR} ON	Hz	50.05	50.00	50.05	50.00	55.00
.057	T f >	Time OFF	ms	50	50	50	50	180000
Comment:		f > on has a fixed offset of 0.01 Hz subtracted to the displayed value						
Only active for:		Voltage > 60% U _{NOM}						

Underfrequency1					Conformity Range		Possible Range	
ID				Default	Min	Max	Min	Max
.059	f < off	f _{THR} OFF	Hz	47.50	45.00	50.00	45.00	50.00
.060	f < on	f _{THR} ON	Hz	49.50	47.55	50.00	45.00	50.00
.061	T f <	Time OFF	ms	50	50	50	50	180000
Comment:		f < on has a fixed offset of 0.01 Hz added to the displayed value						
Only active for:		Voltage > 60% U _{NOM}						

Frequency measuring in general					Conformity Range		Possible Range	
ID				Default	Min	Max	Min	Max
.113	F wnd	Window length	ms	Fixed window length 100ms				

Auxiliary Contact type					Conformity Range		Possible Range	
ID				Default	Min	Max	Min	Max
.099	Contact	Type	n.c. (normally closed)		n.o. (normally opened) n.c. (normally closed)		n.o. (normally opened) n.c. (normally closed) dis. (disabled)	
.100	T Contact	Time OFF	ms	Fixed to 500ms				
.114	I3 STOP	Type	n.o. (normally opened)		n.o. (normally opened) n.c. (normally closed) dis. (disabled)		n.o. (normally opened) n.c. (normally closed) dis. (disabled)	

Turn-on delay					Conformity Range		Possible Range	
ID				Default	Min	Max	Min	Max
.102	Ton delay	Turn on time	s	60	0	300	0	600

Password					Default	Min	Max
ID							
.106	PW1	1 st digit of Password			0	0	9
.107	PW2	2 nd digit of Password			0	0	9
.108	PW3	3 rd digit of Password			0	0	9
.109	PW4	4 th digit of Password			0	0	9
Remark:		If all 4 digits of the Password are 0 (default setting) the Password request is skipped					

Device Information		
ID		
.105	ID: xxxxxx	xxxxx = Device ID
	SW: aa.dd.ccb	dd: Software version of Display Software aa: Software version of Measuring Software cc: Index of Configuration set b: Version of Configuration set

10.5 Oberösterreich OOE TOR R25 NS SYNC [ID 822] Typ A/B low voltage synchr. generators

Connection Mode			Conformity Range		Possible Range	
ID		Default				
.003	Connection	4-wire (LN)	4-wire (LN)		2-wire, 3-wire, 4-wire (LN), 4-wire (LN+LL)	

Nominal Voltage				Conformity Range		Possible Range	
ID		Default		Min	Max	Min	Max
.005	ULN/LL nom	Unom Y	V	230.0	57.5	230.0	28.8
		Unom Δ	V	400.0	100.0	400.0	50.0

Functional Safety			Conformity Range		Possible Range	
ID		Default				
.007	Errtol	Fixed to 2ch				
Remark:		2ch means: 2 channel with functional safety and 2 auxilliary contacts necessary				

Undervoltage1 Line to Neutral				Conformity Range		Possible Range	
ID		Default		Min	Max	Min	Max
.023	Ueff < off	U _{THR} OFF	%Unom	80	10	100	10
.024	Ueff < on	U _{THR} ON	%Unom	85	85	100	10
.025	T Ueff <	Time OFF	ms	200	50	180000	50
Comment:		Ueff < on has a fixed offset of 0.5% U _{NOM} added to the displayed value					
Only active for:		Connection Modes: 2-wire, 4-wire (LN), 4-wire (LN+LL)					

Overvoltage2 Line to Neutral				Conformity Range		Possible Range	
ID		Default		Min	Max	Min	Max
.034	Ueff>>	Enable function		on	on		on / off
.035	Ueff>> off	U _{THR} OFF	%Unom	115	100	130	100
.036	Ueff>> on	U _{THR} ON	%Unom	109	100	109	100
.037	T Ueff>>	Time OFF	ms	100	50	180000	50
Comment:		Ueff>> on has a fixed offset of 0.5% U _{NOM} subtracted from the displayed value					
Only active for:		Connection Modes: 2-wire, 4-wire (LN), 4-wire (LN+LL)					

Undervoltage2 Line to Neutral				Conformity Range		Possible Range	
ID		Default		Min	Max	Min	Max
.038	Ueff<<	Enable function		on	on		on / off
.039	Ueff<< off	U _{THR} OFF	%Unom	30	10	100	10
.040	Ueff<< on	U _{THR} ON	%Unom	85	85	100	0
.041	T Ueff<<	Time OFF	ms	200	50	180000	50
Comment:		Ueff<< on has a fixed offset of 0.5% U _{NOM} added to the displayed value					
Only active for:		Connection Modes: 2-wire, 4-wire (LN), 4-wire (LN+LL)					

10 minutes average overvoltage				Conformity Range		Possible Range	
ID		Default		Min	Max	Min	Max
.042	U10min	Enable function		on	on / off		on / off
.043	U10min off	U _{THR} OFF	%Unom	111	100	130	100
		U _{THR} ON	%Unom	Fixed Hysteresis (0.9% U _{NOM})			
		Time OFF	ms	Fixed to fastest possible disconnection			

Overfrequency1				Conformity Range		Possible Range		
ID				Default	Min	Max	Min	Max
.055	f > off	f _{THR} OFF	Hz	51.50	50.00	55.00	50.00	55.00
.056	f > on	f _{THR} ON	Hz	50.1	50.00	50.1	50.00	55.00
.057	T f >	Time OFF	ms	50	50	50	50	180000
Comment:		f > on has a fixed offset of 0.01 Hz subtracted to the displayed value						
Only active for:		Voltage > 60% U _{NOM}						

Underfrequency1				Conformity Range		Possible Range		
ID				Default	Min	Max	Min	Max
.059	f < off	f _{THR} OFF	Hz	47.50	45.00	50.00	45.00	50.00
.060	f < on	f _{THR} ON	Hz	47.50	47.50	50.00	45.00	50.00
.061	T f <	Time OFF	ms	50	50	50	50	180000
Comment:		f < on has a fixed offset of 0.01 Hz added to the displayed value						
Only active for:		Voltage > 60% U _{NOM}						

Frequency measuring in general				Conformity Range		Possible Range		
ID				Default	Min	Max	Min	Max
.113	F wnd	Window length	ms	Fixed window length 100ms				

Auxiliary Contact type				Conformity Range		Possible Range		
ID				Default	Min	Max	Min	Max
.099	Contact	Type	n.c. (normally closed)		n.o. (normally opened) n.c. (normally closed)		n.o. (normally opened) n.c. (normally closed) dis. (disabled)	
.100	T Contact	Time OFF	ms	Fixed to 500ms				
.114	I3 STOP	Type	n.o. (normally opened)		n.o. (normally opened) n.c. (normally closed) dis. (disabled)		n.o. (normally opened) n.c. (normally closed) dis. (disabled)	

Turn-on delay				Conformity Range		Possible Range		
ID				Default	Min	Max	Min	Max
.102	Ton delay	Turn on time	s	60	0	300	0	600

Password				Default	Min	Max
ID						
.106	PW1	1 st digit of Password		0	0	9
.107	PW2	2 nd digit of Password		0	0	9
.108	PW3	3 rd digit of Password		0	0	9
.109	PW4	4 th digit of Password		0	0	9
Remark:		If all 4 digits of the Password are 0 (default setting) the Password request is skipped				

Device Information		
ID		
.105	ID: xxxxxx	xxxxx = Device ID
	SW: aa.dd.ccb	dd: Software version of Display Software aa: Software version of Measuring Software cc: Index of Configuration set b: Version of Configuration set

10.6 Oberösterreich OOE TOR R25 NS ASYNC [ID 823] Typ A/B low voltage asynchr. generators

Connection Mode			Conformity Range		Possible Range	
ID		Default				
.003	Connection	4-wire (LN)	4-wire (LN)		2-wire, 3-wire, 4-wire (LN), 4-wire (LN+LL)	

Nominal Voltage				Conformity Range		Possible Range	
ID		Default		Min	Max	Min	Max
.005	ULN/LL nom	Unom Y	V	230.0	57.5	230.0	28.8
		Unom Δ	V	400.0	100.0	400.0	50.0

Functional Safety			Conformity Range		Possible Range	
ID		Default				
.007	Errtol	Fixed to 2ch				
Remark:		2ch means: 2 channel with functional safety and 2 auxilliary contacts necessary				

Undervoltage1 Line to Neutral				Conformity Range		Possible Range	
ID		Default		Min	Max	Min	Max
.023	Ueff < off	U _{THR} OFF	%Unom	80	10	100	10
.024	Ueff < on	U _{THR} ON	%Unom	85	85	100	10
.025	T Ueff <	Time OFF	ms	1500	50	180000	50
Comment:		Ueff < on has a fixed offset of 0.5% U _{NOM} added to the displayed value					
Only active for:		Connection Modes: 2-wire, 4-wire (LN), 4-wire (LN+LL)					

Overvoltage2 Line to Neutral				Conformity Range		Possible Range	
ID		Default		Min	Max	Min	Max
.034	Ueff>>	Enable function		on	on		on / off
.035	Ueff>> off	U _{THR} OFF	%Unom	115	100	130	100
.036	Ueff>> on	U _{THR} ON	%Unom	109	100	109	100
.037	T Ueff>>	Time OFF	ms	100	50	180000	50
Comment:		Ueff>> on has a fixed offset of 0.5% U _{NOM} subtracted from the displayed value					
Only active for:		Connection Modes: 2-wire, 4-wire (LN), 4-wire (LN+LL)					

Undervoltage2 Line to Neutral				Conformity Range		Possible Range	
ID		Default		Min	Max	Min	Max
.038	Ueff<<	Enable function		on	on		on / off
.039	Ueff<< off	U _{THR} OFF	%Unom	25	10	100	10
.040	Ueff<< on	U _{THR} ON	%Unom	85	85	100	0
.041	T Ueff<<	Time OFF	ms	500	50	180000	50
Comment:		Ueff<< on has a fixed offset of 0.5% U _{NOM} added to the displayed value					
Only active for:		Connection Modes: 2-wire, 4-wire (LN), 4-wire (LN+LL)					

10 minutes average overvoltage				Conformity Range		Possible Range	
ID		Default		Min	Max	Min	Max
.042	U10min	Enable function		on	on / off		on / off
.043	U10min off	U _{THR} OFF	%Unom	111	100	130	100
		U _{THR} ON	%Unom	Fixed Hysteresis (0.9% U _{NOM})			
		Time OFF	ms	Fixed to fastest possible disconnection			

Overfrequency1					Conformity Range		Possible Range	
ID				Default	Min	Max	Min	Max
.055	f > off	f _{THR} OFF	Hz	51.50	50.00	55.00	50.00	55.00
.056	f > on	f _{THR} ON	Hz	50.1	50.00	50.1	50.00	55.00
.057	T f >	Time OFF	ms	50	50	50	50	180000
Comment:		f > on has a fixed offset of 0.01 Hz subtracted to the displayed value						
Only active for:		Voltage > 60% U _{NOM}						

Underfrequency1					Conformity Range		Possible Range	
ID				Default	Min	Max	Min	Max
.059	f < off	f _{THR} OFF	Hz	47.50	45.00	50.00	45.00	50.00
.060	f < on	f _{THR} ON	Hz	47.50	47.50	50.00	45.00	50.00
.061	T f <	Time OFF	ms	50	50	50	50	180000
Comment:		f < on has a fixed offset of 0.01 Hz added to the displayed value						
Only active for:		Voltage > 60% U _{NOM}						

Frequency measuring in general					Conformity Range		Possible Range	
ID				Default	Min	Max	Min	Max
.113	F wnd	Window length	ms	Fixed window length 100ms				

Auxiliary Contact type					Conformity Range		Possible Range	
ID				Default	Min	Max	Min	Max
.099	Contact	Type	n.c. (normally closed)		n.o. (normally opened) n.c. (normally closed)		n.o. (normally opened) n.c. (normally closed) dis. (disabled)	
.100	T Contact	Time OFF	ms	Fixed to 500ms				
.114	I3 STOP	Type	n.o. (normally opened)		n.o. (normally opened) n.c. (normally closed) dis. (disabled)		n.o. (normally opened) n.c. (normally closed) dis. (disabled)	

Turn-on delay					Conformity Range		Possible Range	
ID				Default	Min	Max	Min	Max
.102	Ton delay	Turn on time	s	60	0	300	0	600

Password					Default	Min	Max
ID							
.106	PW1	1 st digit of Password			0	0	9
.107	PW2	2 nd digit of Password			0	0	9
.108	PW3	3 rd digit of Password			0	0	9
.109	PW4	4 th digit of Password			0	0	9
Remark:		If all 4 digits of the Password are 0 (default setting) the Password request is skipped					

Device Information		
ID		
.105	ID: xxxxxx	xxxxx = Device ID
	SW: aa.dd.ccb	dd: Software version of Display Software aa: Software version of Measuring Software cc: Index of Configuration set b: Version of Configuration set

10.7 Oberösterreich OOE TOR R25 MS SYNC [ID 872] Typ A/B medium voltage synchr. generators

Connection Mode			Conformity Range		Possible Range	
ID		Default				
.003	Connection	3-wire	3-wire		2-wire, 3-wire, 4-wire (LN), 4-wire (LN+LL)	

Nominal Voltage				Conformity Range		Possible Range		
ID				Default	Min	Max	Min	Max
.005	ULN/LL nom	Unom Y	V	60.4	57.5	230.0	28.8	241.4
		Unom Δ	V	105.0	100.0	400.0	50.0	420.0
Comment:		Default for Uc=21kV and 200:1 voltage transformer or Uc=31,7kV and 300:1						

Functional Safety			Conformity Range		Possible Range	
ID		Default				
.007	Errtol	Fixed to 2ch				
Remark:		2ch means: 2 channel with functional safety and 2 auxilliary contacts necessary				

Overvoltage1 Line to Line				Conformity Range		Possible Range		
ID				Default	Min	Max	Min	Max
.011	U > off	U _{THR} OFF	%Unom	104.5	100	130	100	135
.012	U > on	U _{THR} ON	%Unom	104.5	100	109	100	135
.013	T U >	Time OFF	ms	60000	50	180000	50	180000
Comment:		U > on has a fixed offset of 0.5% U _{NOM} subtracted from the displayed value						
Only active for:		Connection Modes: 3-wire, 4-wire (LN+LL)						

Undervoltage1 Line to Line				Conformity Range		Possible Range		
ID				Default	Min	Max	Min	Max
.015	U < off	U _{THR} OFF	%Unom	70	10	100	10	100
.016	U < on	U _{THR} ON	%Unom	85	85	100	10	100
.017	T U <	Time OFF	ms	200	50	180000	50	180000
Comment:		U < on has a fixed offset of 0.5% U _{NOM} added to the displayed value						
Only active for:		Connection Modes: 3-wire, 4-wire (LN+LL)						

Overvoltage2 Line to Line				Conformity Range		Possible Range		
ID				Default	Min	Max	Min	Max
.026	U >>	Enable function		on	on		on /off	
.027	U >> off	U _{THR} OFF	%Unom	108	100	130	100	135
.028	U >> on	U _{THR} ON	%Unom	104.5	100	109	100	135
.029	T U >>	Time OFF	ms	100	50	180000	50	180000
Comment:		U >> on has a fixed offset of 0.5% U _{NOM} subtracted from the displayed value						
Only active for:		Connection Modes: 3-wire, 4-wire (LN+LL)						

Undervoltage2 Line to Line				Conformity Range		Possible Range		
ID				Default	Min	Max	Min	Max
.030	U <<	Enable function		on	on		on /off	
.031	U << off	U _{THR} OFF	%Unom	30	10	100	10	100
.032	U << on	U _{THR} ON	%Unom	85	85	100	0	100
.033	T U <<	Time OFF	ms	200	50	180000	50	180000
Comment:		U << on has a fixed offset of 0.5% U _{NOM} added to the displayed value						
Only active for:		Connection Modes: 3-wire, 4-wire (LN+LL)						

10 minutes average overvoltage				Conformity Range		Possible Range		
ID				Default	Min	Max	Min	Max
.042	U10min	Enable function		off	on / off		on /off	
.043	U10min off	U _{THR} OFF	%Unom	104.5	100	130	100	135
		U _{THR} ON	%Unom	Fixed Hysteresis (0.9% U _{NOM})				
		Time OFF	ms	Fixed to fastest possible disconnection				

Overfrequency1				Conformity Range		Possible Range		
ID				Default	Min	Max	Min	Max
.055	f > off	f _{THR} OFF	Hz	51.50	50.00	55.00	50.00	55.00
.056	f > on	f _{THR} ON	Hz	50.1	50.00	50.1	50.00	55.00
.057	T f >	Time OFF	ms	50	50	50	50	180000
Comment:		f > on has a fixed offset of 0.01 Hz subtracted to the displayed value						
Only active for:		Voltage > 60% U _{NOM}						

Underfrequency1				Conformity Range		Possible Range		
ID				Default	Min	Max	Min	Max
.059	f < off	f _{THR} OFF	Hz	47.50	45.00	50.00	45.00	50.00
.060	f < on	f _{THR} ON	Hz	47.50	47.5	50.00	45.00	50.00
.061	T f <	Time OFF	ms	50	50	50	50	180000
Comment:		f < on has a fixed offset of 0.01 Hz added to the displayed value						
Only active for:		Voltage > 60% U _{NOM}						

Frequency measuring in general				Conformity Range		Possible Range		
ID				Default	Min	Max	Min	Max
.113	F wnd	Window length	ms	Fixed window length 100ms				

Auxiliary Contact type				Conformity Range		Possible Range		
ID				Default	Min	Max	Min	Max
.099	Contact	Type	n.c. (normally closed)		n.o. (normally opened) n.c. (normally closed)		n.o. (normally opened) n.c. (normally closed) dis. (disabled)	
.100	T Contact	Time OFF	ms	Fixed to 500ms				
.114	I3 STOP	Type	n.o. (normally opened)		n.o. (normally opened) n.c. (normally closed) dis. (disabled)		n.o. (normally opened) n.c. (normally closed) dis. (disabled)	

Turn-on delay				Conformity Range		Possible Range		
ID				Default	Min	Max	Min	Max
.102	Ton delay	Turn on time	s	60	0	300	0	600

Password						
ID				Default	Min	Max
.106	PW1	1 st digit of Password		0	0	9
.107	PW2	2 nd digit of Password		0	0	9
.108	PW3	3 rd digit of Password		0	0	9
.109	PW4	4 th digit of Password		0	0	9
Remark:		If all 4 digits of the Password are 0 (default setting) the Password request is skipped				

Device Information		
ID		
.105	ID: xxxxxx SW: aa.dd.ccb	xxxxx = Device ID dd: Software version of Display Software aa: Software version of Measuring Software cc: Index of Configuration set b: Version of Configuration set

10.8 Oberösterreich OOE TOR R25 MS ASYNC [ID 873] Typ A/B med. voltage asynchr. generators

Connection Mode			Conformity Range		Possible Range	
ID		Default				
.003	Connection	3-wire	3-wire		2-wire, 3-wire, 4-wire (LN), 4-wire (LN+LL)	

Nominal Voltage				Conformity Range		Possible Range		
ID				Default	Min	Max	Min	Max
.005	ULN/LL nom	Unom Y	V	60.4	57.5	230.0	28.8	241.4
		Unom Δ	V	105.0	100.0	400.0	50.0	420.0
Comment:		Default for Uc=21kV and 200:1 voltage transformer or Uc=31,7kV and 300:1						

Functional Safety			Conformity Range		Possible Range	
ID		Default				
.007	Errtol	Fixed to 2ch				
Remark:		2ch means: 2 channel with functional safety and 2 auxilliary contacts necessary				

Overvoltage1 Line to Line				Conformity Range		Possible Range		
ID				Default	Min	Max	Min	Max
.011	U > off	U _{THR} OFF	%Unom	104.5	100	130	100	135
.012	U > on	U _{THR} ON	%Unom	104.5	100	109	100	135
.013	T U >	Time OFF	ms	60000	50	180000	50	180000
Comment:		U > on has a fixed offset of 0.5% U _{NOM} subtracted from the displayed value						
Only active for:		Connection Modes: 3-wire, 4-wire (LN+LL)						

Undervoltage1 Line to Line				Conformity Range		Possible Range		
ID				Default	Min	Max	Min	Max
.015	U < off	U _{THR} OFF	%Unom	80	10	100	10	100
.016	U < on	U _{THR} ON	%Unom	85	85	100	10	100
.017	T U <	Time OFF	ms	1000	50	180000	50	180000
Comment:		U < on has a fixed offset of 0.5% U _{NOM} added to the displayed value						
Only active for:		Connection Modes: 3-wire, 4-wire (LN+LL)						

Overvoltage2 Line to Line				Conformity Range		Possible Range		
ID				Default	Min	Max	Min	Max
.026	U >>	Enable function		on	on		on /off	
.027	U >> off	U _{THR} OFF	%Unom	108	100	130	100	135
.028	U >> on	U _{THR} ON	%Unom	104.5	100	109	100	135
.029	T U >>	Time OFF	ms	100	50	180000	50	180000
Comment:		U >> on has a fixed offset of 0.5% U _{NOM} subtracted from the displayed value						
Only active for:		Connection Modes: 3-wire, 4-wire (LN+LL)						

Undervoltage2 Line to Line				Conformity Range		Possible Range		
ID				Default	Min	Max	Min	Max
.030	U <<	Enable function		on	on		on /off	
.031	U << off	U _{THR} OFF	%Unom	30	10	100	10	100
.032	U << on	U _{THR} ON	%Unom	85	85	100	0	100
.033	T U <<	Time OFF	ms	500	50	180000	50	180000
Comment:		U << on has a fixed offset of 0.5% U _{NOM} added to the displayed value						
Only active for:		Connection Modes: 3-wire, 4-wire (LN+LL)						

10 minutes average overvoltage				Conformity Range		Possible Range		
ID				Default	Min	Max	Min	Max
.042	U10min	Enable function		off	on / off		on / off	
.043	U10min off	U _{THR} OFF	%Unom	104.5	100	130	100	135
		U _{THR} ON	%Unom	Fixed Hysteresis (0.9% U _{NOM})				
		Time OFF	ms	Fixed to fastest possible disconnection				

Overfrequency1				Conformity Range		Possible Range		
ID				Default	Min	Max	Min	Max
.055	f > off	f _{THR} OFF	Hz	51.50	50.00	55.00	50.00	55.00
.056	f > on	f _{THR} ON	Hz	50.1	50.00	50.1	50.00	55.00
.057	T f >	Time OFF	ms	50	50	50	50	180000
Comment:		f > on has a fixed offset of 0.01 Hz subtracted to the displayed value						
Only active for:		Voltage > 60% U _{NOM}						

Underfrequency1				Conformity Range		Possible Range		
ID				Default	Min	Max	Min	Max
.059	f < off	f _{THR} OFF	Hz	47.50	45.00	50.00	45.00	50.00
.060	f < on	f _{THR} ON	Hz	47.50	47.5	50.00	45.00	50.00
.061	T f <	Time OFF	ms	50	50	50	50	180000
Comment:		f < on has a fixed offset of 0.01 Hz added to the displayed value						
Only active for:		Voltage > 60% U _{NOM}						

Frequency measuring in general				Conformity Range		Possible Range		
ID				Default	Min	Max	Min	Max
.113	F wnd	Window length	ms	Fixed window length 100ms				

Auxiliary Contact type				Conformity Range		Possible Range		
ID				Default	Min	Max	Min	Max
.099	Contact	Type	n.c. (normally closed)		n.o. (normally opened) n.c. (normally closed)		n.o. (normally opened) n.c. (normally closed) dis. (disabled)	
.100	T Contact	Time OFF	ms	Fixed to 500ms				
.114	I3 STOP	Type	n.o. (normally opened)		n.o. (normally opened) n.c. (normally closed) dis. (disabled)		n.o. (normally opened) n.c. (normally closed) dis. (disabled)	

Turn-on delay				Conformity Range		Possible Range		
ID				Default	Min	Max	Min	Max
.102	Ton delay	Turn on time	s	60	0	300	0	600

Password						
ID				Default	Min	Max
.106	PW1	1 st digit of Password		0	0	9
.107	PW2	2 nd digit of Password		0	0	9
.108	PW3	3 rd digit of Password		0	0	9
.109	PW4	4 th digit of Password		0	0	9
Remark:		If all 4 digits of the Password are 0 (default setting) the Password request is skipped				

Device Information		
ID		
.105	ID: xxxxxx SW: aa.dd.ccb	xxxxx = Device ID dd: Software version of Display Software aa: Software version of Measuring Software cc: Index of Configuration set b: Version of Configuration set

10.9 Wien TOR R25 NS SYNC [ID 832] Typ A/B low voltage synchr. generators

Connection Mode			Conformity Range		Possible Range	
ID		Default				
.003	Connection	4-wire (LN)	4-wire (LN)		2-wire, 3-wire, 4-wire (LN), 4-wire (LN+LL)	

Nominal Voltage				Conformity Range		Possible Range		
ID		Default		Min	Max	Min	Max	
.005	ULN/LL nom	Unom Y	V	230.0	57.5	230.0	28.8	241.4
		Unom Δ	V	400.0	100.0	400.0	50.0	420.0

Functional Safety			Conformity Range		Possible Range	
ID		Default				
.007	Errtol	Fixed to 2ch				
Remark:		2ch means: 2 channel with functional safety and 2 auxilliary contacts necessary				

Overvoltage1 Line to Neutral				Conformity Range		Possible Range		
ID		Default		Min	Max	Min	Max	
.018	Ueff >	Enable function		on / off		on / off		
.019	Ueff > off	U _{THR} OFF	%Unom	108	100	130	100	135
.020	Ueff > on	U _{THR} ON	%Unom	107	100	108	100	135
.021	T Ueff >	Time OFF	ms	60000	50	180000	50	180000
Comment:		Ueff > on has a fixed offset of 0.5% U _{NOM} subtracted from the displayed value						
Only active for:		Connection Modes: 2-wire, 4-wire (LN), 4-wire (LN+LL)						

Undervoltage1 Line to Neutral				Conformity Range		Possible Range		
ID		Default		Min	Max	Min	Max	
.023	Ueff < off	U _{THR} OFF	%Unom	80	10	100	10	100
.024	Ueff < on	U _{THR} ON	%Unom	90	86	100	10	100
.025	T Ueff <	Time OFF	ms	1000	50	180000	50	180000
Comment:		Ueff < on has a fixed offset of 0.5% U _{NOM} added to the displayed value						
Only active for:		Connection Modes: 2-wire, 4-wire (LN), 4-wire (LN+LL)						

Overvoltage2 Line to Neutral				Conformity Range		Possible Range		
ID		Default		Min	Max	Min	Max	
.034	Ueff>>	Enable function		on		on / off		
.035	Ueff>> off	U _{THR} OFF	%Unom	115	100	130	100	135
.036	Ueff>> on	U _{THR} ON	%Unom	107	100	108	100	135
.037	T Ueff>>	Time OFF	ms	100	50	180000	50	180000
Comment:		Ueff>> on has a fixed offset of 0.5% U _{NOM} subtracted from the displayed value						
Only active for:		Connection Modes: 2-wire, 4-wire (LN), 4-wire (LN+LL)						

Undervoltage2 Line to Neutral				Conformity Range		Possible Range		
ID		Default		Min	Max	Min	Max	
.038	Ueff<<	Enable function		on		on / off		
.039	Ueff<< off	U _{THR} OFF	%Unom	30	10	100	10	100
.040	Ueff<< on	U _{THR} ON	%Unom	90	86	100	0	100
.041	T Ueff<<	Time OFF	ms	200	50	180000	50	180000
Comment:		Ueff<< on has a fixed offset of 0.5% U _{NOM} added to the displayed value						
Only active for:		Connection Modes: 2-wire, 4-wire (LN), 4-wire (LN+LL)						

10 minutes average overvoltage				Conformity Range		Possible Range		
ID				Default	Min	Max	Min	Max
.042	U10min	Enable function		off	on / off		on /off	
.043	U10min off	U _{THR} OFF	%Unom	108	100	130	100	135
		U _{THR} ON	%Unom	Fixed Hysteresis (0.9% U _{NOM})				
		Time OFF	ms	Fixed to fastest possible disconnection				

Overfrequency1				Conformity Range		Possible Range		
ID				Default	Min	Max	Min	Max
.055	f > off	f _{THR} OFF	Hz	51.00	50.00	55.00	50.00	55.00
.056	f > on	f _{THR} ON	Hz	50.05	50.00	50.05	50.00	55.00
.057	T f >	Time OFF	ms	50	50	50	50	180000
Comment:		f > on has a fixed offset of 0.01 Hz subtracted to the displayed value						
Only active for:		Voltage > 60% U _{NOM}						

Underfrequency1				Conformity Range		Possible Range		
ID				Default	Min	Max	Min	Max
.059	f < off	f _{THR} OFF	Hz	47.50	45.00	50.00	45.00	50.00
.060	f < on	f _{THR} ON	Hz	49.50	47.55	50.00	45.00	50.00
.061	T f <	Time OFF	ms	50	50	50	50	180000
Comment:		f < on has a fixed offset of 0.01 Hz added to the displayed value						
Only active for:		Voltage > 60% U _{NOM}						

Frequency measuring in general				Conformity Range		Possible Range		
ID				Default	Min	Max	Min	Max
.113	F wnd	Window length	ms	Fixed window length 100ms				

Auxiliary Contact type				Conformity Range		Possible Range		
ID				Default	Min	Max	Min	Max
.099	Contact	Type	n.c. (normally closed)		n.o. (normally opened) n.c. (normally closed)		n.o. (normally opened) n.c. (normally closed) dis. (disabled)	
.100	T Contact	Time OFF	ms	Fixed to 500ms				
.114	I3 STOP	Type	n.o. (normally opened)		n.o. (normally opened) n.c. (normally closed) dis. (disabled)		n.o. (normally opened) n.c. (normally closed) dis. (disabled)	

Turn-on delay				Conformity Range		Possible Range		
ID				Default	Min	Max	Min	Max
.102	Ton delay	Turn on time	s	60	0	300	0	600

Password							
ID				Default	Min	Max	
.106	PW1	1 st digit of Password		0	0	9	
.107	PW2	2 nd digit of Password		0	0	9	
.108	PW3	3 rd digit of Password		0	0	9	
.109	PW4	4 th digit of Password		0	0	9	
Remark:		If all 4 digits of the Password are 0 (default setting) the Password request is skipped					

Device Information		
ID		
.105	ID: xxxxxx SW: aa.dd.ccb	xxxxx = Device ID dd: Software version of Display Software aa: Software version of Measuring Software cc: Index of Configuration set b: Version of Configuration set

10.10 Wien TOR R25 NS ASYNC [ID 833] Typ A/B low voltage asynchr. generators

Connection Mode			Conformity Range		Possible Range	
ID		Default				
.003	Connection	4-wire (LN)	4-wire (LN)		2-wire, 3-wire, 4-wire (LN), 4-wire (LN+LL)	

Nominal Voltage				Conformity Range		Possible Range		
ID		Default		Min	Max	Min	Max	
.005	ULN/LL nom	Unom Y	V	230.0	57.5	230.0	28.8	241.4
		Unom Δ	V	400.0	100.0	400.0	50.0	420.0

Functional Safety			Conformity Range		Possible Range	
ID		Default				
.007	Errtol	Fixed to 2ch				
Remark:		2ch means: 2 channel with functional safety and 2 auxilliary contacts necessary				

Overvoltage1 Line to Neutral				Conformity Range		Possible Range		
ID		Default		Min	Max	Min	Max	
.018	Ueff >	Enable function		on / off		on / off		
.019	Ueff > off	U _{THR} OFF	%Unom	108	100	130	100	135
.020	Ueff > on	U _{THR} ON	%Unom	107	100	108	100	135
.021	T Ueff >	Time OFF	ms	60000	50	180000	50	180000
Comment:		Ueff > on has a fixed offset of 0.5% U _{NOM} subtracted from the displayed value						
Only active for:		Connection Modes: 2-wire, 4-wire (LN), 4-wire (LN+LL)						

Undervoltage1 Line to Neutral				Conformity Range		Possible Range		
ID		Default		Min	Max	Min	Max	
.023	Ueff < off	U _{THR} OFF	%Unom	80	10	100	10	100
.024	Ueff < on	U _{THR} ON	%Unom	90	86	100	10	100
.025	T Ueff <	Time OFF	ms	1000	50	180000	50	180000
Comment:		Ueff < on has a fixed offset of 0.5% U _{NOM} added to the displayed value						
Only active for:		Connection Modes: 2-wire, 4-wire (LN), 4-wire (LN+LL)						

Overvoltage2 Line to Neutral				Conformity Range		Possible Range		
ID		Default		Min	Max	Min	Max	
.034	Ueff>>	Enable function		on		on / off		
.035	Ueff>> off	U _{THR} OFF	%Unom	115	100	130	100	135
.036	Ueff>> on	U _{THR} ON	%Unom	107	100	108	100	135
.037	T Ueff>>	Time OFF	ms	100	50	180000	50	180000
Comment:		Ueff>> on has a fixed offset of 0.5% U _{NOM} subtracted from the displayed value						
Only active for:		Connection Modes: 2-wire, 4-wire (LN), 4-wire (LN+LL)						

Undervoltage2 Line to Neutral				Conformity Range		Possible Range		
ID		Default		Min	Max	Min	Max	
.038	Ueff<<	Enable function		on		on / off		
.039	Ueff<< off	U _{THR} OFF	%Unom	30	10	100	10	100
.040	Ueff<< on	U _{THR} ON	%Unom	90	86	100	0	100
.041	T Ueff<<	Time OFF	ms	200	50	180000	50	180000
Comment:		Ueff<< on has a fixed offset of 0.5% U _{NOM} added to the displayed value						
Only active for:		Connection Modes: 2-wire, 4-wire (LN), 4-wire (LN+LL)						

10 minutes average overvoltage				Conformity Range		Possible Range		
ID				Default	Min	Max	Min	Max
.042	U10min	Enable function		off	on / off		on /off	
.043	U10min off	U _{THR} OFF	%Unom	108	100	130	100	135
		U _{THR} ON	%Unom	Fixed Hysteresis (0.9% U _{NOM})				
		Time OFF	ms	Fixed to fastest possible disconnection				

Overfrequency1				Conformity Range		Possible Range		
ID				Default	Min	Max	Min	Max
.055	f > off	f _{THR} OFF	Hz	51.00	50.00	55.00	50.00	55.00
.056	f > on	f _{THR} ON	Hz	50.05	50.00	50.05	50.00	55.00
.057	T f >	Time OFF	ms	50	50	50	50	180000
Comment:		f > on has a fixed offset of 0.01 Hz subtracted to the displayed value						
Only active for:		Voltage > 60% U _{NOM}						

Underfrequency1				Conformity Range		Possible Range		
ID				Default	Min	Max	Min	Max
.059	f < off	f _{THR} OFF	Hz	47.50	45.00	50.00	45.00	50.00
.060	f < on	f _{THR} ON	Hz	49.50	47.55	50.00	45.00	50.00
.061	T f <	Time OFF	ms	50	50	50	50	180000
Comment:		f < on has a fixed offset of 0.01 Hz added to the displayed value						
Only active for:		Voltage > 60% U _{NOM}						

Frequency measuring in general				Conformity Range		Possible Range		
ID				Default	Min	Max	Min	Max
.113	F wnd	Window length	ms	Fixed window length 100ms				

Auxiliary Contact type				Conformity Range		Possible Range		
ID				Default	Min	Max	Min	Max
.099	Contact	Type	n.c. (normally closed)		n.o. (normally opened) n.c. (normally closed)		n.o. (normally opened) n.c. (normally closed) dis. (disabled)	
.100	T Contact	Time OFF	ms	Fixed to 500ms				
.114	I3 STOP	Type	n.o. (normally opened)		n.o. (normally opened) n.c. (normally closed) dis. (disabled)		n.o. (normally opened) n.c. (normally closed) dis. (disabled)	

Turn-on delay				Conformity Range		Possible Range		
ID				Default	Min	Max	Min	Max
.102	Ton delay	Turn on time	s	60	0	300	0	600

Password							
ID				Default	Min	Max	
.106	PW1	1 st digit of Password		0	0	9	
.107	PW2	2 nd digit of Password		0	0	9	
.108	PW3	3 rd digit of Password		0	0	9	
.109	PW4	4 th digit of Password		0	0	9	
Remark:		If all 4 digits of the Password are 0 (default setting) the Password request is skipped					

Device Information		
ID		
.105	ID: xxxxxx SW: aa.dd.ccb	xxxxx = Device ID dd: Software version of Display Software aa: Software version of Measuring Software cc: Index of Configuration set b: Version of Configuration set

10.11 Wien TOR R25 MS SYNC [ID 882] Typ A/B medium voltage synchr. generators

Connection Mode			Conformity Range		Possible Range	
ID		Default				
.003	Connection	3-wire	3-wire		2-wire, 3-wire, 4-wire (LN), 4-wire (LN+LL)	

Nominal Voltage				Conformity Range		Possible Range		
ID		Default		Min	Max	Min	Max	
.005	ULN/LL nom	Unom Y	V	58.7	57.5	230.0	28.8	241.4
		Unom Δ	V	102.0	100.0	400.0	50.0	420.0
Comment:		Default for Uc=21kV and 200:1 voltage transformer or Uc=31,7kV and 300:1						

Functional Safety			Conformity Range		Possible Range	
ID		Default				
.007	Errtol	Fixed to 2ch				
Remark:		2ch means: 2 channel with functional safety and 2 auxilliary contacts necessary				

Overvoltage1 Line to Line				Conformity Range		Possible Range		
ID		Default		Min	Max	Min	Max	
.011	U > off	U _{THR} OFF	%Unom	108	100	130	100	135
.012	U > on	U _{THR} ON	%Unom	107	100	108	100	135
.013	T U >	Time OFF	ms	60000	50	180000	50	180000
Comment:		U > on has a fixed offset of 0.5% U _{NOM} subtracted from the displayed value						
Only active for:		Connection Modes: 3-wire, 4-wire (LN+LL)						

Undervoltage1 Line to Line				Conformity Range		Possible Range		
ID		Default		Min	Max	Min	Max	
.015	U < off	U _{THR} OFF	%Unom	80	10	100	10	100
.016	U < on	U _{THR} ON	%Unom	90	86	100	10	100
.017	T U <	Time OFF	ms	1000	50	180000	50	180000
Comment:		U < on has a fixed offset of 0.5% U _{NOM} added to the displayed value						
Only active for:		Connection Modes: 3-wire, 4-wire (LN+LL)						

Overvoltage2 Line to Line				Conformity Range		Possible Range		
ID		Default		Min	Max	Min	Max	
.026	U >>	Enable function		on	on	on /off		
.027	U >> off	U _{THR} OFF	%Unom	115	100	130	100	135
.028	U >> on	U _{THR} ON	%Unom	107	100	108	100	135
.029	T U >>	Time OFF	ms	100	50	180000	50	180000
Comment:		U >> on has a fixed offset of 0.5% U _{NOM} subtracted from the displayed value						
Only active for:		Connection Modes: 3-wire, 4-wire (LN+LL)						

Undervoltage2 Line to Line				Conformity Range		Possible Range		
ID		Default		Min	Max	Min	Max	
.030	U <<	Enable function		on	on	on /off		
.031	U << off	U _{THR} OFF	%Unom	30	10	100	10	100
.032	U << on	U _{THR} ON	%Unom	90	86	100	0	100
.033	T U <<	Time OFF	ms	200	50	180000	50	180000
Comment:		U << on has a fixed offset of 0.5% U _{NOM} added to the displayed value						
Only active for:		Connection Modes: 3-wire, 4-wire (LN+LL)						

Overfrequency1					Conformity Range		Possible Range	
ID				Default	Min	Max	Min	Max
.055	f > off	f _{THR} OFF	Hz	51.00	50.00	55.00	50.00	55.00
.056	f > on	f _{THR} ON	Hz	50.05	50.00	50.05	50.00	55.00
.057	T f >	Time OFF	ms	50	50	50	50	180000
Comment:		f > on has a fixed offset of 0.01 Hz subtracted to the displayed value						
Only active for:		Voltage > 60% U _{NOM}						

Underfrequency1					Conformity Range		Possible Range	
ID				Default	Min	Max	Min	Max
.059	f < off	f _{THR} OFF	Hz	47.50	45.00	50.00	45.00	50.00
.060	f < on	f _{THR} ON	Hz	49.50	47.55	50.00	45.00	50.00
.061	T f <	Time OFF	ms	50	50	50	50	180000
Comment:		f < on has a fixed offset of 0.01 Hz added to the displayed value						
Only active for:		Voltage > 60% U _{NOM}						

Frequency measuring in general					Conformity Range		Possible Range	
ID				Default	Min	Max	Min	Max
.113	F wnd	Window length	ms	Fixed window length 100ms				

Auxiliary Contact type					Conformity Range		Possible Range	
ID				Default	Min	Max	Min	Max
.099	Contact	Type	n.c. (normally closed)		n.o. (normally opened) n.c. (normally closed)		n.o. (normally opened) n.c. (normally closed) dis. (disabled)	
.100	T Contact	Time OFF	ms	Fixed to 500ms				
.114	I3 STOP	Type	n.o. (normally opened)		n.o. (normally opened) n.c. (normally closed) dis. (disabled)		n.o. (normally opened) n.c. (normally closed) dis. (disabled)	

Turn-on delay					Conformity Range		Possible Range	
ID				Default	Min	Max	Min	Max
.102	Ton delay	Turn on time	s	60	0	300	0	600

Password					Default	Min	Max
ID							
.106	PW1	1 st digit of Password			0	0	9
.107	PW2	2 nd digit of Password			0	0	9
.108	PW3	3 rd digit of Password			0	0	9
.109	PW4	4 th digit of Password			0	0	9
Remark:		If all 4 digits of the Password are 0 (default setting) the Password request is skipped					

Device Information		
ID		
.105	ID: xxxxxx	xxxxx = Device ID
	SW: aa.dd.ccb	dd: Software version of Display Software aa: Software version of Measuring Software cc: Index of Configuration set b: Version of Configuration set

10.12 Wien TOR R25 MS ASYNC [ID 883] Typ A/B medium voltage asynchr. generators

Connection Mode			Conformity Range		Possible Range	
ID		Default				
.003	Connection	3-wire	3-wire		2-wire, 3-wire, 4-wire (LN), 4-wire (LN+LL)	

Nominal Voltage				Conformity Range		Possible Range		
ID		Default		Min	Max	Min	Max	
.005	ULN/LL nom	Unom Y	V	58.7	57.5	230.0	28.8	241.4
		Unom Δ	V	102.0	100.0	400.0	50.0	420.0
Comment:		Default for Uc=21kV and 200:1 voltage transformer or Uc=31,7kV and 300:1						

Functional Safety			Conformity Range		Possible Range	
ID		Default				
.007	Errtol	Fixed to 2ch				
Remark:		2ch means: 2 channel with functional safety and 2 auxilliary contacts necessary				

Overvoltage1 Line to Line				Conformity Range		Possible Range		
ID		Default		Min	Max	Min	Max	
.011	U > off	U _{THR} OFF	%Unom	108	100	130	100	135
.012	U > on	U _{THR} ON	%Unom	107	100	108	100	135
.013	T U >	Time OFF	ms	60000	50	180000	50	180000
Comment:		U > on has a fixed offset of 0.5% U _{NOM} subtracted from the displayed value						
Only active for:		Connection Modes: 3-wire, 4-wire (LN+LL)						

Undervoltage1 Line to Line				Conformity Range		Possible Range		
ID		Default		Min	Max	Min	Max	
.015	U < off	U _{THR} OFF	%Unom	80	10	100	10	100
.016	U < on	U _{THR} ON	%Unom	90	86	100	10	100
.017	T U <	Time OFF	ms	1000	50	180000	50	180000
Comment:		U < on has a fixed offset of 0.5% U _{NOM} added to the displayed value						
Only active for:		Connection Modes: 3-wire, 4-wire (LN+LL)						

Overvoltage2 Line to Line				Conformity Range		Possible Range		
ID		Default		Min	Max	Min	Max	
.026	U >>	Enable function		on	on		on /off	
.027	U >> off	U _{THR} OFF	%Unom	115	100	130	100	135
.028	U >> on	U _{THR} ON	%Unom	107	100	108	100	135
.029	T U >>	Time OFF	ms	100	50	180000	50	180000
Comment:		U >> on has a fixed offset of 0.5% U _{NOM} subtracted from the displayed value						
Only active for:		Connection Modes: 3-wire, 4-wire (LN+LL)						

Undervoltage2 Line to Line				Conformity Range		Possible Range		
ID		Default		Min	Max	Min	Max	
.030	U <<	Enable function		on	on		on /off	
.031	U << off	U _{THR} OFF	%Unom	30	10	100	10	100
.032	U << on	U _{THR} ON	%Unom	90	86	100	0	100
.033	T U <<	Time OFF	ms	200	50	180000	50	180000
Comment:		U << on has a fixed offset of 0.5% U _{NOM} added to the displayed value						
Only active for:		Connection Modes: 3-wire, 4-wire (LN+LL)						

Overfrequency1					Conformity Range		Possible Range	
ID				Default	Min	Max	Min	Max
.055	f > off	f _{THR} OFF	Hz	51.00	50.00	55.00	50.00	55.00
.056	f > on	f _{THR} ON	Hz	50.05	50.00	50.05	50.00	55.00
.057	T f >	Time OFF	ms	50	50	50	50	180000
Comment:		f > on has a fixed offset of 0.01 Hz subtracted to the displayed value						
Only active for:		Voltage > 60% U _{NOM}						

Underfrequency1					Conformity Range		Possible Range	
ID				Default	Min	Max	Min	Max
.059	f < off	f _{THR} OFF	Hz	47.50	45.00	50.00	45.00	50.00
.060	f < on	f _{THR} ON	Hz	49.50	47.55	50.00	45.00	50.00
.061	T f <	Time OFF	ms	50	50	50	50	180000
Comment:		f < on has a fixed offset of 0.01 Hz added to the displayed value						
Only active for:		Voltage > 60% U _{NOM}						

Frequency measuring in general					Conformity Range		Possible Range	
ID				Default	Min	Max	Min	Max
.113	F wnd	Window length	ms	Fixed window length 100ms				

Auxiliary Contact type					Conformity Range		Possible Range	
ID				Default	Min	Max	Min	Max
.099	Contact	Type	n.c. (normally closed)		n.o. (normally opened) n.c. (normally closed)		n.o. (normally opened) n.c. (normally closed) dis. (disabled)	
.100	T Contact	Time OFF	ms	Fixed to 500ms				
.114	I3 STOP	Type	n.o. (normally opened)		n.o. (normally opened) n.c. (normally closed) dis. (disabled)		n.o. (normally opened) n.c. (normally closed) dis. (disabled)	

Turn-on delay					Conformity Range		Possible Range	
ID				Default	Min	Max	Min	Max
.102	Ton delay	Turn on time	s	60	0	300	0	600

Password					Default	Min	Max
ID							
.106	PW1	1 st digit of Password			0	0	9
.107	PW2	2 nd digit of Password			0	0	9
.108	PW3	3 rd digit of Password			0	0	9
.109	PW4	4 th digit of Password			0	0	9
Remark:		If all 4 digits of the Password are 0 (default setting) the Password request is skipped					

Device Information		
ID		
.105	ID: xxxxxx SW: aa.dd.ccb	xxxxx = Device ID dd: Software version of Display Software aa: Software version of Measuring Software cc: Index of Configuration set b: Version of Configuration set

10.13 TIROL TOR NS SYNC [ID 812] Typ A/B low voltage synchr. generators

Connection Mode			Conformity Range		Possible Range	
ID		Default				
.003	Connection	4-wire (LN)	4-wire (LN)		2-wire, 3-wire, 4-wire (LN), 4-wire (LN+LL)	

Nominal Voltage				Conformity Range		Possible Range		
ID		Default		Min	Max	Min	Max	
.005	ULN/LL nom	Unom Y	V	230.0	57.5	230.0	28.8	241.4
		Unom Δ	V	400.0	100.0	400.0	50.0	420.0

Functional Safety			Conformity Range		Possible Range	
ID		Default				
.007	Errtol	Fixed to 2ch				
Remark:		2ch means: 2 channel with functional safety and 2 auxilliary contacts necessary				

Overvoltage1 Line to Neutral				Conformity Range		Possible Range		
ID		Default		Min	Max	Min	Max	
.018	Ueff >	Enable function		on / off		on / off		
.019	Ueff > off	U _{THR} OFF	%Unom	111	100	130	100	135
.020	Ueff > on	U _{THR} ON	%Unom	109	100	109	100	135
.021	T Ueff >	Time OFF	ms	60000	50	180000	50	180000
Comment:		Ueff > on has a fixed offset of 0.5% U _{NOM} subtracted from the displayed value						
Only active for:		Connection Modes: 2-wire, 4-wire (LN), 4-wire (LN+LL)						

Undervoltage1 Line to Neutral				Conformity Range		Possible Range		
ID		Default		Min	Max	Min	Max	
.023	Ueff < off	U _{THR} OFF	%Unom	80	10	100	10	100
.024	Ueff < on	U _{THR} ON	%Unom	86	86	100	10	100
.025	T Ueff <	Time OFF	ms	1000	50	180000	50	180000
Comment:		Ueff < on has a fixed offset of 0.5% U _{NOM} added to the displayed value						
Only active for:		Connection Modes: 2-wire, 4-wire (LN), 4-wire (LN+LL)						

Overvoltage2 Line to Neutral				Conformity Range		Possible Range		
ID		Default		Min	Max	Min	Max	
.034	Ueff>>	Enable function		on		on / off		
.035	Ueff>> off	U _{THR} OFF	%Unom	115	100	130	100	135
.036	Ueff>> on	U _{THR} ON	%Unom	109	100	109	100	135
.037	T Ueff>>	Time OFF	ms	100	50	180000	50	180000
Comment:		Ueff>> on has a fixed offset of 0.5% U _{NOM} subtracted from the displayed value						
Only active for:		Connection Modes: 2-wire, 4-wire (LN), 4-wire (LN+LL)						

Undervoltage2 Line to Neutral				Conformity Range		Possible Range		
ID		Default		Min	Max	Min	Max	
.038	Ueff<<	Enable function		on		on / off		
.039	Ueff<< off	U _{THR} OFF	%Unom	30	10	100	10	100
.040	Ueff<< on	U _{THR} ON	%Unom	86	86	100	0	100
.041	T Ueff<<	Time OFF	ms	200	50	180000	50	180000
Comment:		Ueff<< on has a fixed offset of 0.5% U _{NOM} added to the displayed value						
Only active for:		Connection Modes: 2-wire, 4-wire (LN), 4-wire (LN+LL)						

10 minutes average overvoltage				Conformity Range		Possible Range		
ID				Default	Min	Max	Min	Max
.042	U10min	Enable function		off	on / off		on /off	
.043	U10min off	U _{THR} OFF	%Unom	111	100	130	100	135
		U _{THR} ON	%Unom	Fixed Hysteresis (0.9% U _{NOM})				
		Time OFF	ms	Fixed to fastest possible disconnection				

Overfrequency1				Conformity Range		Possible Range		
ID				Default	Min	Max	Min	Max
.055	f > off	f _{THR} OFF	Hz	51.50	50.00	55.00	50.00	55.00
.056	f > on	f _{THR} ON	Hz	50.1	50.00	50.1	50.00	55.00
.057	T f >	Time OFF	ms	50	50	50	50	180000
Comment:		f > on has a fixed offset of 0.01 Hz subtracted to the displayed value						
Only active for:		Voltage > 60% U _{NOM}						

Underfrequency1				Conformity Range		Possible Range		
ID				Default	Min	Max	Min	Max
.059	f < off	f _{THR} OFF	Hz	47.50	45.00	50.00	45.00	50.00
.060	f < on	f _{THR} ON	Hz	47.50	47.50	50.00	45.00	50.00
.061	T f <	Time OFF	ms	50	50	50	50	180000
Comment:		f < on has a fixed offset of 0.01 Hz added to the displayed value						
Only active for:		Voltage > 60% U _{NOM}						

Frequency measuring in general				Conformity Range		Possible Range		
ID				Default	Min	Max	Min	Max
.113	F wnd	Window length	ms	Fixed window length 100ms				

Auxiliary Contact type				Conformity Range		Possible Range		
ID				Default	Min	Max	Min	Max
.099	Contact	Type	n.c. (normally closed)		n.o. (normally opened) n.c. (normally closed)		n.o. (normally opened) n.c. (normally closed) dis. (disabled)	
.100	T Contact	Time OFF	ms	Fixed to 500ms				
.114	I3 STOP	Type	n.o. (normally opened)		n.o. (normally opened) n.c. (normally closed) dis. (disabled)		n.o. (normally opened) n.c. (normally closed) dis. (disabled)	

Turn-on delay				Conformity Range		Possible Range		
ID				Default	Min	Max	Min	Max
.102	Ton delay	Turn on time	s	300	0	300	0	600

Password						
ID				Default	Min	Max
.106	PW1	1 st digit of Password		0	0	9
.107	PW2	2 nd digit of Password		0	0	9
.108	PW3	3 rd digit of Password		0	0	9
.109	PW4	4 th digit of Password		0	0	9
Remark:		If all 4 digits of the Password are 0 (default setting) the Password request is skipped				

Device Information		
ID		
.105	ID: xxxxxx SW: aa.dd.ccb	xxxxx = Device ID dd: Software version of Display Software aa: Software version of Measuring Software cc: Index of Configuration set b: Version of Configuration set

10.14 TIROL TOR NS ASYNC [ID 813] Typ A/B low voltage asynchr. generators

Connection Mode				Conformity Range		Possible Range	
ID	Default						
.003	Connection	4-wire (LN)	4-wire (LN)		2-wire, 3-wire, 4-wire (LN), 4-wire (LN+LL)		

Nominal Voltage				Conformity Range		Possible Range		
ID	Default		Min	Max	Min	Max		
.005	ULN/LL nom	Unom Y	V	230.0	57.5	230.0	28.8	241.4
		Unom Δ	V	400.0	100.0	400.0	50.0	420.0

Functional Safety				Conformity Range		Possible Range	
ID	Default						
.007	Errtol	Fixed to 2ch					
Remark:		2ch means: 2 channel with functional safety and 2 auxilliary contacts necessary					

Overvoltage1 Line to Neutral				Conformity Range		Possible Range		
ID	Default		Min	Max	Min	Max		
.018	Ueff >	Enable function	on	on / off		on / off		
.019	Ueff > off	U _{THR} OFF	%Unom	111	100	130	100	135
.020	Ueff > on	U _{THR} ON	%Unom	109	100	109	100	135
.021	T Ueff >	Time OFF	ms	60000	50	180000	50	180000
Comment:		Ueff > on has a fixed offset of 0.5% U _{NOM} subtracted from the displayed value						
Only active for:		Connection Modes: 2-wire, 4-wire (LN), 4-wire (LN+LL)						

Undervoltage1 Line to Neutral				Conformity Range		Possible Range		
ID	Default		Min	Max	Min	Max		
.023	Ueff < off	U _{THR} OFF	%Unom	80	10	100	10	100
.024	Ueff < on	U _{THR} ON	%Unom	86	86	100	10	100
.025	T Ueff <	Time OFF	ms	1500	50	180000	50	180000
Comment:		Ueff < on has a fixed offset of 0.5% U _{NOM} added to the displayed value						
Only active for:		Connection Modes: 2-wire, 4-wire (LN), 4-wire (LN+LL)						

Overvoltage2 Line to Neutral				Conformity Range		Possible Range		
ID	Default		Min	Max	Min	Max		
.034	Ueff>>	Enable function	on	on		on / off		
.035	Ueff>> off	U _{THR} OFF	%Unom	115	100	130	100	135
.036	Ueff>> on	U _{THR} ON	%Unom	109	100	109	100	135
.037	T Ueff>>	Time OFF	ms	100	50	180000	50	180000
Comment:		Ueff>> on has a fixed offset of 0.5% U _{NOM} subtracted from the displayed value						
Only active for:		Connection Modes: 2-wire, 4-wire (LN), 4-wire (LN+LL)						

Undervoltage2 Line to Neutral				Conformity Range		Possible Range		
ID	Default		Min	Max	Min	Max		
.038	Ueff<<	Enable function	on	on		on / off		
.039	Ueff<< off	U _{THR} OFF	%Unom	25	10	100	10	100
.040	Ueff<< on	U _{THR} ON	%Unom	86	86	100	0	100
.041	T Ueff<<	Time OFF	ms	500	50	180000	50	180000
Comment:		Ueff<< on has a fixed offset of 0.5% U _{NOM} added to the displayed value						
Only active for:		Connection Modes: 2-wire, 4-wire (LN), 4-wire (LN+LL)						

10 minutes average overvoltage				Conformity Range		Possible Range		
ID				Default	Min	Max	Min	Max
.042	U10min	Enable function		off	on / off		on / off	
.043	U10min off	U _{THR} OFF	%Unom	111	100	130	100	135
		U _{THR} ON	%Unom	Fixed Hysteresis (0.9% U _{NOM})				
		Time OFF	ms	Fixed to fastest possible disconnection				

Overfrequency1				Conformity Range		Possible Range		
ID				Default	Min	Max	Min	Max
.055	f > off	f _{THR} OFF	Hz	51.50	50.00	55.00	50.00	55.00
.056	f > on	f _{THR} ON	Hz	50.1	50.00	50.1	50.00	55.00
.057	T f >	Time OFF	ms	50	50	50	50	180000
Comment:		f > on has a fixed offset of 0.01 Hz subtracted to the displayed value						
Only active for:		Voltage > 60% U _{NOM}						

Underfrequency1				Conformity Range		Possible Range		
ID				Default	Min	Max	Min	Max
.059	f < off	f _{THR} OFF	Hz	47.50	45.00	50.00	45.00	50.00
.060	f < on	f _{THR} ON	Hz	47.50	47.5	50.00	45.00	50.00
.061	T f <	Time OFF	ms	50	50	50	50	180000
Comment:		f < on has a fixed offset of 0.01 Hz added to the displayed value						
Only active for:		Voltage > 60% U _{NOM}						

Frequency measuring in general				Conformity Range		Possible Range		
ID				Default	Min	Max	Min	Max
.113	F wnd	Window length	ms	Fixed window length 100ms				

Auxiliary Contact type				Conformity Range		Possible Range		
ID				Default	Min	Max	Min	Max
.099	Contact	Type	n.c. (normally closed)		n.o. (normally opened) n.c. (normally closed)		n.o. (normally opened) n.c. (normally closed) dis. (disabled)	
.100	T Contact	Time OFF	ms	Fixed to 500ms				
.114	I3 STOP	Type	n.o. (normally opened)		n.o. (normally opened) n.c. (normally closed) dis. (disabled)		n.o. (normally opened) n.c. (normally closed) dis. (disabled)	

Turn-on delay				Conformity Range		Possible Range		
ID				Default	Min	Max	Min	Max
.102	Ton delay	Turn on time	s	300	0	300	0	600

Password						
ID				Default	Min	Max
.106	PW1	1 st digit of Password		0	0	9
.107	PW2	2 nd digit of Password		0	0	9
.108	PW3	3 rd digit of Password		0	0	9
.109	PW4	4 th digit of Password		0	0	9
Remark:		If all 4 digits of the Password are 0 (default setting) the Password request is skipped				

Device Information		
ID		
.105	ID: xxxxxx SW: aa.dd.ccb	xxxxx = Device ID dd: Software version of Display Software aa: Software version of Measuring Software cc: Index of Configuration set b: Version of Configuration set

10.15 TIROL TOR MS SYNC [ID 862] Typ A/B medium voltage synchr. generators

Connection Mode			Conformity Range		Possible Range	
ID		Default				
.003	Connection	3-wire	3-wire		2-wire, 3-wire, 4-wire (LN), 4-wire (LN+LL)	

Nominal Voltage				Conformity Range		Possible Range		
ID		Default		Min	Max	Min	Max	
.005	ULN/LL nom	Unom Y	V	57.5	57.5	230.0	28.8	241.4
		Unom Δ	V	100.0	100.0	400.0	50.0	420.0
Comment:		Default for Uc=21kV and 200:1 voltage transformer or Uc=31,7kV and 300:1						

Functional Safety			Conformity Range		Possible Range	
ID		Default				
.007	Errtol	Fixed to 2ch				
Remark:		2ch means: 2 channel with functional safety and 2 auxilliary contacts necessary				

Overvoltage1 Line to Line				Conformity Range		Possible Range		
ID		Default		Min	Max	Min	Max	
.011	U > off	U _{THR} OFF	%Unom	105	100	130	100	135
.012	U > on	U _{THR} ON	%Unom	104	100	108	100	135
.013	T U >	Time OFF	ms	60000	50	180000	50	180000
Comment:		U > on has a fixed offset of 0.5% U _{NOM} subtracted from the displayed value						
Only active for:		Connection Modes: 3-wire, 4-wire (LN+LL)						

Undervoltage1 Line to Line				Conformity Range		Possible Range		
ID		Default		Min	Max	Min	Max	
.015	U < off	U _{THR} OFF	%Unom	70	10	100	10	100
.016	U < on	U _{THR} ON	%Unom	86	86	100	10	100
.017	T U <	Time OFF	ms	1000	50	180000	50	180000
Comment:		U < on has a fixed offset of 0.5% U _{NOM} added to the displayed value						
Only active for:		Connection Modes: 3-wire, 4-wire (LN+LL)						

Overvoltage2 Line to Line				Conformity Range		Possible Range		
ID		Default		Min	Max	Min	Max	
.026	U >>	Enable function		on	on	on /off		
.027	U >> off	U _{THR} OFF	%Unom	115	100	130	100	135
.028	U >> on	U _{THR} ON	%Unom	104	100	108	100	135
.029	T U >>	Time OFF	ms	100	50	180000	50	180000
Comment:		U >> on has a fixed offset of 0.5% U _{NOM} subtracted from the displayed value						
Only active for:		Connection Modes: 3-wire, 4-wire (LN+LL)						

Undervoltage2 Line to Line				Conformity Range		Possible Range		
ID		Default		Min	Max	Min	Max	
.030	U <<	Enable function		on	on	on /off		
.031	U << off	U _{THR} OFF	%Unom	30	10	100	10	100
.032	U << on	U _{THR} ON	%Unom	86	86	100	0	100
.033	T U <<	Time OFF	ms	200	50	180000	50	180000
Comment:		U << on has a fixed offset of 0.5% U _{NOM} added to the displayed value						
Only active for:		Connection Modes: 3-wire, 4-wire (LN+LL)						

Overfrequency1					Conformity Range		Possible Range	
ID				Default	Min	Max	Min	Max
.055	f > off	f _{THR} OFF	Hz	51.50	50.00	55.00	50.00	55.00
.056	f > on	f _{THR} ON	Hz	50.10	50.00	50.10	50.00	55.00
.057	T f >	Time OFF	ms	50	50	50	50	180000
Comment:		f > on has a fixed offset of 0.01 Hz subtracted to the displayed value						
Only active for:		Voltage > 60% U _{NOM}						

Underfrequency1					Conformity Range		Possible Range	
ID				Default	Min	Max	Min	Max
.059	f < off	f _{THR} OFF	Hz	47.50	45.00	50.00	45.00	50.00
.060	f < on	f _{THR} ON	Hz	47.50	47.50	50.00	45.00	50.00
.061	T f <	Time OFF	ms	50	50	50	50	180000
Comment:		f < on has a fixed offset of 0.01 Hz added to the displayed value						
Only active for:		Voltage > 60% U _{NOM}						

Frequency measuring in general					Conformity Range		Possible Range	
ID				Default	Min	Max	Min	Max
.113	F wnd	Window length	ms	Fixed window length 100ms				

Auxiliary Contact type					Conformity Range		Possible Range	
ID				Default	Min	Max	Min	Max
.099	Contact	Type	n.c. (normally closed)		n.o. (normally opened) n.c. (normally closed)		n.o. (normally opened) n.c. (normally closed) dis. (disabled)	
.100	T Contact	Time OFF	ms	Fixed to 500ms				
.114	I3 STOP	Type	n.o. (normally opened)		n.o. (normally opened) n.c. (normally closed) dis. (disabled)		n.o. (normally opened) n.c. (normally closed) dis. (disabled)	

Turn-on delay					Conformity Range		Possible Range	
ID				Default	Min	Max	Min	Max
.102	Ton delay	Turn on time	s	300	0	300	0	600

Password					Default	Min	Max
ID							
.106	PW1	1 st digit of Password			0	0	9
.107	PW2	2 nd digit of Password			0	0	9
.108	PW3	3 rd digit of Password			0	0	9
.109	PW4	4 th digit of Password			0	0	9
Remark:		If all 4 digits of the Password are 0 (default setting) the Password request is skipped					

Device Information		
ID		
.105	ID: xxxxxx	xxxxx = Device ID
	SW: aa.dd.ccb	dd: Software version of Display Software aa: Software version of Measuring Software cc: Index of Configuration set b: Version of Configuration set

10.16 TIROL TOR MS ASYNC [ID 863] Typ A/B medium voltage asynchr. generators

Connection Mode			Conformity Range		Possible Range	
ID		Default				
.003	Connection	3-wire	3-wire		2-wire, 3-wire, 4-wire (LN), 4-wire (LN+LL)	

Nominal Voltage				Conformity Range		Possible Range	
ID		Default		Min	Max	Min	Max
.005	ULN/LL nom	Unom Y	V	57.5	57.5	28.8	241.4
		Unom Δ	V	100.0	100.0	50.0	420.0
Comment:		Default for Uc=21kV and 200:1 voltage transformer or Uc=31,7kV and 300:1					

Functional Safety			Conformity Range		Possible Range	
ID		Default				
.007	Errtol	Fixed to 2ch				
Remark:		2ch means: 2 channel with functional safety and 2 auxilliary contacts necessary				

Overvoltage1 Line to Line				Conformity Range		Possible Range		
ID		Default		Min	Max	Min	Max	
.011	U > off	U _{THR} OFF	%Unom	105	100	130	100	135
.012	U > on	U _{THR} ON	%Unom	104	100	108	100	135
.013	T U >	Time OFF	ms	60000	50	180000	50	180000
Comment:		U > on has a fixed offset of 0.5% U _{NOM} subtracted from the displayed value						
Only active for:		Connection Modes: 3-wire, 4-wire (LN+LL)						

Undervoltage1 Line to Line				Conformity Range		Possible Range		
ID		Default		Min	Max	Min	Max	
.015	U < off	U _{THR} OFF	%Unom	80	10	100	10	100
.016	U < on	U _{THR} ON	%Unom	86	86	100	10	100
.017	T U <	Time OFF	ms	1500	50	180000	50	180000
Comment:		U < on has a fixed offset of 0.5% U _{NOM} added to the displayed value						
Only active for:		Connection Modes: 3-wire, 4-wire (LN+LL)						

Overvoltage2 Line to Line				Conformity Range		Possible Range		
ID		Default		Min	Max	Min	Max	
.026	U >>	Enable function		on	on	on /off		
.027	U >> off	U _{THR} OFF	%Unom	115	100	130	100	135
.028	U >> on	U _{THR} ON	%Unom	104	100	108	100	135
.029	T U >>	Time OFF	ms	100	50	180000	50	180000
Comment:		U >> on has a fixed offset of 0.5% U _{NOM} subtracted from the displayed value						
Only active for:		Connection Modes: 3-wire, 4-wire (LN+LL)						

Undervoltage2 Line to Line				Conformity Range		Possible Range		
ID		Default		Min	Max	Min	Max	
.030	U <<	Enable function		on	on	on /off		
.031	U << off	U _{THR} OFF	%Unom	30	10	100	10	100
.032	U << on	U _{THR} ON	%Unom	86	86	100	0	100
.033	T U <<	Time OFF	ms	500	50	180000	50	180000
Comment:		U << on has a fixed offset of 0.5% U _{NOM} added to the displayed value						
Only active for:		Connection Modes: 3-wire, 4-wire (LN+LL)						

Overfrequency1					Conformity Range		Possible Range	
ID				Default	Min	Max	Min	Max
.055	f > off	f _{THR} OFF	Hz	51.50	50.00	55.00	50.00	55.00
.056	f > on	f _{THR} ON	Hz	50.10	50.00	50.10	50.00	55.00
.057	T f >	Time OFF	ms	50	50	50	50	180000
Comment:		f > on has a fixed offset of 0.01 Hz subtracted to the displayed value						
Only active for:		Voltage > 60% U _{NOM}						

Underfrequency1					Conformity Range		Possible Range	
ID				Default	Min	Max	Min	Max
.059	f < off	f _{THR} OFF	Hz	47.50	45.00	50.00	45.00	50.00
.060	f < on	f _{THR} ON	Hz	47.50	47.50	50.00	45.00	50.00
.061	T f <	Time OFF	ms	50	50	50	50	180000
Comment:		f < on has a fixed offset of 0.01 Hz added to the displayed value						
Only active for:		Voltage > 60% U _{NOM}						

Frequency measuring in general					Conformity Range		Possible Range	
ID				Default	Min	Max	Min	Max
.113	F wnd	Window length	ms	Fixed window length 100ms				

Auxiliary Contact type					Conformity Range		Possible Range	
ID				Default	Min	Max	Min	Max
.099	Contact	Type	n.c. (normally closed)		n.o. (normally opened) n.c. (normally closed)		n.o. (normally opened) n.c. (normally closed) dis. (disabled)	
.100	T Contact	Time OFF	ms	Fixed to 500ms				
.114	I3 STOP	Type	n.o. (normally opened)		n.o. (normally opened) n.c. (normally closed) dis. (disabled)		n.o. (normally opened) n.c. (normally closed) dis. (disabled)	

Turn-on delay					Conformity Range		Possible Range	
ID				Default	Min	Max	Min	Max
.102	Ton delay	Turn on time	s	300	0	300	0	600

Password					Default	Min	Max
ID							
.106	PW1	1 st digit of Password			0	0	9
.107	PW2	2 nd digit of Password			0	0	9
.108	PW3	3 rd digit of Password			0	0	9
.109	PW4	4 th digit of Password			0	0	9
Remark:		If all 4 digits of the Password are 0 (default setting) the Password request is skipped					

Device Information		
ID		
.105	ID: xxxxxx	xxxxx = Device ID
	SW: aa.dd.ccb	dd: Software version of Display Software aa: Software version of Measuring Software cc: Index of Configuration set b: Version of Configuration set

10.17 VDE-AR-N 4105:2018 ≤50kW [ID 311]

Connection Mode			Conformity Range		Possible Range	
ID		Default				
.003	Connection	4-wire (LN+LL)	2-wire, 3-wire, 4-wire (LN), 4-wire (LN+LL)		2-wire, 3-wire, 4-wire (LN), 4-wire (LN+LL)	

Nominal Voltage				Conformity Range		Possible Range	
ID		Default		Min	Max	Min	Max
.005	ULN/LL nom	Unom Y Unom Δ	V V	Fixed to 230.0 / 400.0			

Functional Safety			Conformity Range		Possible Range	
ID		Default				
.007	Errtol	1ch	1ch		2ch, 1ch	
Remark:		2ch means: 2 channel with functional safety and 2 auxilliary contacts necessary 1ch means: 1 channel without functional safety and 1 auxilliary contact1 necessary				

Overvoltage1 Line to Line				Conformity Range		Possible Range	
ID		Default		Min	Max	Min	Max
.011	ULL >> off	U _{THR} OFF	%Unom	Fixed to 115% U _{NOM}			
.012	ULL >> on	U _{THR} ON	%Unom	110	110	100	110
		Time OFF	ms	Fixed to fastest possible disconnection			
Comment:		ULL >> on has a fixed offset of 0.5% U _{NOM} subtracted from the displayed value					

Undervoltage1 Line to Line				Conformity Range		Possible Range	
ID		Default		Min	Max	Min	Max
.015	ULL < off	U _{THR} OFF	%Unom	80	85	80	85
.016	ULL < on	U _{THR} ON	%Unom	85	85	85	100
		Time OFF	ms	Fixed to fastest possible disconnection			
Comment:		ULL < on has a fixed offset of 0.5% U _{NOM} added to the displayed value					

Overvoltage1 Line to Neutral				Conformity Range		Possible Range	
ID		Default		Min	Max	Min	Max
.019	ULN >> off	U _{THR} OFF	%Unom	Fixed to 115% U _{NOM}			
.020	ULN >> on	U _{THR} ON	%Unom	110	110	100	110
		Time OFF	ms	Fixed to fastest possible disconnection			
Comment:		ULN >> on has a fixed offset of 0.5% U _{NOM} subtracted from the displayed value					

Undervoltage1 Line to Neutral				Conformity Range		Possible Range	
ID		Default		Min	Max	Min	Max
.023	ULN < off	U _{THR} OFF	%Unom	80	85	80	85
.024	ULN < on	U _{THR} ON	%Unom	85	85	85	100
		Time OFF	ms	Fixed to fastest possible disconnection			
Comment:		ULN < on has a fixed offset of 0.5% U _{NOM} added to the displayed value					

10 minutes average overvoltage				Conformity Range		Possible Range	
ID		Default		Min	Max	Min	Max
.043	U > off	U _{THR} OFF	%Unom	110	115	110	115
		U _{THR} ON	%Unom	Fixed Hysteresis (0.9% U _{NOM})			
		Time OFF	ms	Fixed to fastest possible disconnection			

Overfrequency1				Conformity Range		Possible Range		
ID				Default	Min	Max	Min	Max
.055	f > off	f _{THR} OFF	Hz	Fixed to 51.50Hz				
.056	f > on	f _{THR} ON	Hz	50.10	50.10	50.10	50.00	50.10
		Time OFF	ms	Fixed to fastest possible disconnection				

Underfrequency1				Conformity Range		Possible Range		
ID				Default	Min	Max	Min	Max
.059	f < off	f _{THR} OFF	Hz	Fixed to 47.50Hz				
.060	f < on	f _{THR} ON	Hz	47.50	47.50	47.50	47.50	50.00
		Time OFF	ms	Fixed to fastest possible disconnection				
Comment:		f < on has a fixed offset of 0.025 Hz added to the displayed value						

Random overfrequency				Conformity Range		Possible Range		
ID				Default	Min	Max	Min	Max
.086	f > random	Enable function		off	on / off		on / off	
.087	f > random	f _{THR} OFF	Hz		50.20	51.50	50.20	51.50
		f _{THR} ON	Hz	Fixed reconnection frequency of 50.10Hz				
		Time OFF	ms	Fixed to fastest possible disconnection				
Comment:		The random f _{THR} OFF threshold is shown in .087 and cannot be edited						

Frequency measuring in general				Conformity Range		Possible Range		
ID				Default	Min	Max	Min	Max
.113	F wnd	Window length	ms	Fixed window length 100ms				

Auxiliary Contact type				Conformity Range		Possible Range		
ID				Default	Min	Max	Min	Max
.099	Contact	Type	n.c. (normally closed)		n.o. (normally opened) n.c. (normally closed)		n.o. (normally opened) n.c. (normally closed) dis. (disabled)	
.100	T Contact	Time OFF	ms	Fixed to 100ms				
.110	T ConDelOn	Time ON	ms	100	100	10000	100	300000
.114	I3 STOP	Type	n.o. (normally opened)		n.o. (normally opened) n.c. (normally closed) dis. (disabled)		n.o. (normally opened) n.c. (normally closed) dis. (disabled)	

Turn-on delay				Conformity Range		Possible Range		
ID				Default	Min	Max	Min	Max
.102	Ton delay	Turn on time	s	60	60	60	1	600

Random Turn-on delay				Conformity Range		Possible Range		
ID				Default	Min	Max	Min	Max
.103	Ton random	Enable function		off	on / off		on / off	
.104	Ton random	Turn on time	s		60	600	60	600
Comment:		The random time value is shown in .104 and cannot be edited						

Password							
ID				Default	Min	Max	
.106	PW1	1 st digit of Password			4	0	9
.107	PW2	2 nd digit of Password			1	0	9
.108	PW3	3 rd digit of Password			0	0	9
.109	PW4	4 th digit of Password			5	0	9
Remark:		If all 4 digits of the Password are 0 (default setting) the Password request is skipped					

Device Information		
ID		
.105	ID: xxxxxx SW: aa.dd.ccb	xxxxx = Device ID dd: Software version of Display Software aa: Software version of Measuring Software cc: Index of Configuration set b: Version of Configuration set

10.18 VDE-AR-N 4105:2018 >50kW [ID 312]

Connection Mode			Conformity Range		Possible Range	
ID		Default				
.003	Connection	4-wire (LN+LL)	2-wire, 3-wire, 4-wire (LN), 4-wire (LN+LL)		2-wire, 3-wire, 4-wire (LN), 4-wire (LN+LL)	

Nominal Voltage				Conformity Range		Possible Range	
ID			Default	Min	Max	Min	Max
.005	ULN/LL nom	Unom Y Unom Δ	V V	Fixed to 230.0 / 400.0			

Functional Safety			Conformity Range		Possible Range	
ID		Default				
.007	Errtol	1ch	1ch		2ch, 1ch	
Remark:		2ch means: 2 channel with functional safety and 2 auxilliary contacts necessary 1ch means: 1 channel without functional safety and 1 auxilliary contact1 necessary				

Overvoltage1 Line to Line				Conformity Range		Possible Range	
ID			Default	Min	Max	Min	Max
.011	ULL >> off	U _{THR} OFF	%Unom	Fixed to 125% U _{NOM}			
.012	ULL >> on	U _{THR} ON	%Unom	110	110	100	110
		Time OFF	ms	Fixed to fastest possible disconnection			
Comment:		ULL >> on has a fixed offset of 0.5% U _{NOM} subtracted from the displayed value					

Undervoltage1 Line to Line				Conformity Range		Possible Range	
ID			Default	Min	Max	Min	Max
.015	ULL < off	U _{THR} OFF	%Unom	Fixed to 80% U _{NOM}			
.016	ULL < on	U _{THR} ON	%Unom	85	85	85	100
.017	T ULL <	Time OFF	ms	1000	50	1000	10000
Comment:		ULL < on has a fixed offset of 0.5% U _{NOM} added to the displayed value					

Overvoltage1 Line to Neutral				Conformity Range		Possible Range	
ID			Default	Min	Max	Min	Max
.019	ULN >> off	U _{THR} OFF	%Unom	Fixed to 125% U _{NOM}			
.020	ULN >> on	U _{THR} ON	%Unom	110	110	100	110
		Time OFF	ms	Fixed to fastest possible disconnection			
Comment:		ULN >> on has a fixed offset of 0.5% U _{NOM} subtracted from the displayed value					

Undervoltage1 Line to Neutral				Conformity Range		Possible Range	
ID			Default	Min	Max	Min	Max
.023	ULN < off	U _{THR} OFF	%Unom	Fixed to 80% U _{NOM}			
.024	ULN < on	U _{THR} ON	%Unom	85	85	85	100
.025	T ULN <	Time OFF	ms	1000	50	1000	10000
Comment:		ULN < on has a fixed offset of 0.5% U _{NOM} added to the displayed value					

Undervoltage2 Line to Line				Conformity Range		Possible Range	
ID			Default	Min	Max	Min	Max
.031	ULL << off	U _{THR} OFF	%Unom	Fixed to 45% U _{NOM}			
.032	ULL << on	U _{THR} ON	%Unom	85	85	85	100
.033	T ULL <<	Time OFF	ms	300	50	300	10000
Comment:		ULL << on has a fixed offset of 0.5% U _{NOM} added to the displayed value					

Undervoltage2 Line to Neutral				Conformity Range		Possible Range		
ID				Default	Min	Max	Min	Max
.039	ULN << off	U _{THR} OFF	%Unom	Fixed to 45% U _{NOM}				
.040	ULN << on	U _{THR} ON	%Unom	85	85	85	85	100
.041	T ULN <<	Time OFF	ms	200	50	300000	50	300000
Comment:		ULN << on has a fixed offset of 0.5% U _{NOM} added to the displayed value						

10 minutes average overvoltage				Conformity Range		Possible Range		
ID				Default	Min	Max	Min	Max
.043	U > off	U _{THR} OFF	%Unom	110	110	115	110	115
		U _{THR} ON	%Unom	Fixed Hysteresis (0.9% U _{NOM})				
		Time OFF	ms	Fixed to fastest possible disconnection				

Overfrequency1				Conformity Range		Possible Range		
ID				Default	Min	Max	Min	Max
.055	f > off	f _{THR} OFF	Hz	Fixed to 51.50Hz				
.056	f > on	f _{THR} ON	Hz	50.10	50.10	50.10	50.00	50.10
		Time OFF	ms	Fixed to fastest possible disconnection				

Underfrequency1				Conformity Range		Possible Range		
ID				Default	Min	Max	Min	Max
.059	f < off	f _{THR} OFF	Hz	Fixed to 47.50Hz				
.060	f < on	f _{THR} ON	Hz	47.50	47.50	47.50	47.50	50.00
		Time OFF	ms	Fixed to fastest possible disconnection				
Comment:		f < on has a fixed offset of 0.025 Hz added to the displayed value						

Random overfrequency				Conformity Range		Possible Range		
ID				Default	Min	Max	Min	Max
.086	f > random	Enable function		off	on / off		on / off	
.087	f > random	f _{THR} OFF	Hz		50.20	51.50	50.20	51.50
		f _{THR} ON	Hz	Fixed reconnection frequency of 50.10Hz				
		Time OFF	ms	Fixed to fastest possible disconnection				
Comment:		The random f _{THR} OFF threshold is shown in .087 and cannot be edited						

Frequency measuring in general				Conformity Range		Possible Range		
ID				Default	Min	Max	Min	Max
.113	F wnd	Window length	ms	Fixed window length 100ms				

Auxiliary Contact type				Conformity Range		Possible Range		
ID			Default		Min	Max	Min	Max
.099	Contact	Type	n.c. (normally closed)		n.o. (normally opened) n.c. (normally closed)		n.o. (normally opened) n.c. (normally closed) dis. (disabled)	
.100	T Contact	Time OFF	ms	Fixed to 100ms				
.110	T ConDelOn	Time ON	ms	100	100	10000	100	300000
.114	I3 STOP	Type	n.o. (normally opened)		n.o. (normally opened) n.c. (normally closed) dis. (disabled)		n.o. (normally opened) n.c. (normally closed) dis. (disabled)	

Turn-on delay				Conformity Range		Possible Range		
ID				Default	Min	Max	Min	Max
.102	Ton delay	Turn on time	s	60	60	60	1	600

Random Turn-on delay				Conformity Range		Possible Range		
ID				Default	Min	Max	Min	Max
.103	Ton random	Enable function		off	on / off		on / off	
.104	Ton random	Turn on time	s		60	600	60	600
Comment:		The random time value is shown in .104 and cannot be edited						

Password						
ID				Default	Min	Max
.106	PW1	1 st digit of Password		4	0	9
.107	PW2	2 nd digit of Password		1	0	9
.108	PW3	3 rd digit of Password		0	0	9
.109	PW4	4 th digit of Password		5	0	9
Remark:		If all 4 digits of the Password are 0 (default setting) the Password request is skipped				

Device Information		
ID		
.105	ID: xxxxxx SW: aa.dd.ccb	xxxxx = Device ID dd: Software version of Display Software aa: Software version of Measuring Software cc: Index of Configuration set b: Version of Configuration set

10.19 VDE-AR-N 4105:2018 Umr [ID 313]

Connection Mode			Conformity Range		Possible Range	
ID		Default				
.003	Connection	4-wire (LN+LL)	2-wire, 3-wire, 4-wire (LN), 4-wire (LN+LL)		2-wire, 3-wire, 4-wire (LN), 4-wire (LN+LL)	

Nominal Voltage				Conformity Range		Possible Range	
ID		Default		Min	Max	Min	Max
.005	ULN/LL nom	Unom Y Unom Δ	V V	Fixed to 230.0 / 400.0			

Functional Safety			Conformity Range		Possible Range	
ID		Default				
.007	Errtol	2ch	2ch		2ch, 1ch	
Remark:		2ch means: 2 channel with functional safety and 2 auxilliary contacts necessary 1ch means: 1 channel without functional safety and 1 auxilliary contact1 necessary				

Overvoltage1 Line to Line				Conformity Range		Possible Range	
ID		Default		Min	Max	Min	Max
.011	ULL >> off	U _{THR} OFF	%Unom	Fixed to 125% U _{NOM}			
.012	ULL >> on	U _{THR} ON	%Unom	110	110	100	110
		Time OFF	ms	Fixed to fastest possible disconnection			
Comment:		ULL >> on has a fixed offset of 0.5% U _{NOM} subtracted from the displayed value					

Undervoltage1 Line to Line				Conformity Range		Possible Range	
ID		Default		Min	Max	Min	Max
.015	ULL < off	U _{THR} OFF	%Unom	Fixed to 80% U _{NOM}			
.016	ULL < on	U _{THR} ON	%Unom	85	85	85	100
		Time OFF	ms	Fixed to 3000ms			
Comment:		ULL < on has a fixed offset of 0.5% U _{NOM} added to the displayed value					

Overvoltage1 Line to Neutral				Conformity Range		Possible Range	
ID		Default		Min	Max	Min	Max
.019	ULN >> off	U _{THR} OFF	%Unom	Fixed to 125% U _{NOM}			
.020	ULN >> on	U _{THR} ON	%Unom	110	110	100	110
		Time OFF	ms	Fixed to fastest possible disconnection			
Comment:		ULN >> on has a fixed offset of 0.5% U _{NOM} subtracted from the displayed value					

Undervoltage1 Line to Neutral				Conformity Range		Possible Range	
ID		Default		Min	Max	Min	Max
.023	ULN < off	U _{THR} OFF	%Unom	Fixed to 80% U _{NOM}			
.024	ULN < on	U _{THR} ON	%Unom	85	85	85	100
		Time OFF	ms	Fixed to 3000ms			
Comment:		ULN < on has a fixed offset of 0.5% U _{NOM} added to the displayed value					

Undervoltage2 Line to Line				Conformity Range		Possible Range	
ID		Default		Min	Max	Min	Max
.031	ULL << off	U _{THR} OFF	%Unom	Fixed to 45% U _{NOM}			
.032	ULL << on	U _{THR} ON	%Unom	85	85	85	100
		Time OFF	ms	Fixed to 300ms			
Comment:		ULL << on has a fixed offset of 0.5% U _{NOM} added to the displayed value					

Undervoltage2 Line to Neutral				Conformity Range		Possible Range		
ID				Default	Min	Max	Min	Max
.039	ULN << off	U _{THR} OFF	%Unom	Fixed to 45% U _{NOM}				
.040	ULN << on	U _{THR} ON	%Unom	85	85	85	85	100
		Time OFF	ms	Fixed to 300ms				
Comment:		ULN << on has a fixed offset of 0.5% U _{NOM} added to the displayed value						

10 minutes average overvoltage				Conformity Range		Possible Range		
ID				Default	Min	Max	Min	Max
.043	U > off	U _{THR} OFF	%Unom	110	110	115	110	115
		U _{THR} ON	%Unom	Fixed Hysteresis (0.9% U _{NOM})				
		Time OFF	ms	Fixed to fastest possible disconnection				

Overfrequency1				Conformity Range		Possible Range		
ID				Default	Min	Max	Min	Max
.055	f > off	f _{THR} OFF	Hz	Fixed to 51.50Hz				
.056	f > on	f _{THR} ON	Hz	50.10	50.10	50.10	50.00	50.10
		Time OFF	ms	Fixed to fastest possible disconnection				

Underfrequency1				Conformity Range		Possible Range		
ID				Default	Min	Max	Min	Max
.059	f < off	f _{THR} OFF	Hz	Fixed to 47.50Hz				
.060	f < on	f _{THR} ON	Hz	47.50	47.50	47.50	47.50	50.00
		Time OFF	ms	Fixed to fastest possible disconnection				
Comment:		f < on has a fixed offset of 0.025 Hz added to the displayed value						

Random overfrequency				Conformity Range		Possible Range		
ID				Default	Min	Max	Min	Max
.086	f > random	Enable function		off	on / off		on / off	
.087	f > random	f _{THR} OFF	Hz		50.20	51.50	50.20	51.50
		f _{THR} ON	Hz	Fixed reconnection frequency of 50.10Hz				
		Time OFF	ms	Fixed to fastest possible disconnection				
Comment:		The random f _{THR} OFF threshold is shown in .087 and cannot be edited						

Frequency measuring in general				Conformity Range		Possible Range		
ID				Default	Min	Max	Min	Max
.113	F wnd	Window length	ms	Fixed window length 100ms				

Auxiliary Contact type				Conformity Range		Possible Range		
ID			Default	Min	Max	Min	Max	
.099	Contact	Type	n.c. (normally closed)	n.o. (normally opened) n.c. (normally closed)		n.o. (normally opened) n.c. (normally closed) dis. (disabled)		
.100	T Contact	Time OFF	ms	Fixed to 100ms				
.110	T ConDelOn	Time ON	ms	100	100	10000	100	300000
.114	I3 STOP	Type	n.o. (normally opened)	n.o. (normally opened) n.c. (normally closed) dis. (disabled)		n.o. (normally opened) n.c. (normally closed) dis. (disabled)		

Turn-on delay				Conformity Range		Possible Range		
ID				Default	Min	Max	Min	Max
.102	Ton delay	Turn on time	s	60	60	60	1	600

Random Turn-on delay				Conformity Range		Possible Range		
ID				Default	Min	Max	Min	Max
.103	Ton random	Enable function		off	on / off		on / off	
.104	Ton random	Turn on time	s		60	600	60	600
Comment:		The random time value is shown in .104 and cannot be edited						

Password						
ID				Default	Min	Max
.106	PW1	1 st digit of Password		4	0	9
.107	PW2	2 nd digit of Password		1	0	9
.108	PW3	3 rd digit of Password		0	0	9
.109	PW4	4 th digit of Password		5	0	9
Remark:		If all 4 digits of the Password are 0 (default setting) the Password request is skipped				

Device Information		
ID		
.105	ID: xxxxxx SW: aa.dd.ccb	xxxxx = Device ID dd: Software version of Display Software aa: Software version of Measuring Software cc: Index of Configuration set b: Version of Configuration set

10.20 VDE-AR-N 4110:2018 TR3-25 [ID 706]

Connection Mode			Conformity Range		Possible Range	
ID		Default				
.003	Connection	4-wire (LN)	3-wire, 4-wire (LN)		2-wire, 3-wire, 4-wire (LN), 4-wire (LN+LL)	

Nominal Voltage				Conformity Range		Possible Range	
ID		Default		Min	Max	Min	Max
.005	ULN/LL nom	Unom Y	V	230.0	57.5	230.0	28.8
		Unom Δ	V	400.0	100.0	400.0	50.0

Functional Safety			Conformity Range		Possible Range	
ID		Default				
.007	Errtol	Fixed to 1ch				
Remark:		1ch means: 1 channel without functional safety and 1 auxilliary contact1 necessary				

Overvoltage1 Line to Line				Conformity Range		Possible Range	
ID		Default		Min	Max	Min	Max
.011	ULL > off	U _{THR} OFF	%Unom	110	100	130	100
		U _{THR} ON	%Unom	Fixed Hysteresis (1% U _{NOM})			
.013	T ULL >	Time OFF	ms	180000	100	180000	100
Only active for:		Connection Modes: 3-wire, 4-wire (LN+LL)					

Undervoltage1 Line to Line				Conformity Range		Possible Range	
ID		Default		Min	Max	Min	Max
.015	ULL < off	U _{THR} OFF	%Unom	80	10	100	10
.016	ULL < on	U _{THR} ON	%Unom	95	95	95	10
.017	T ULL <	Time OFF	ms	1500	1500	2400	50
Comment:		ULL < on has a fixed offset of 0.5% U _{NOM} added to the displayed value					
Only active for:		Connection Modes: 3-wire, 4-wire (LN+LL)					

Overvoltage1 Line to Neutral				Conformity Range		Possible Range	
ID		Default		Min	Max	Min	Max
.019	ULN > off	U _{THR} OFF	%Unom	110	100	130	100
		U _{THR} ON	%Unom	Fixed Hysteresis (1% U _{NOM})			
.021	T ULN >	Time OFF	ms	180000	100	180000	100
Only active for:		Connection Modes: 2-wire, 4-wire (LN), 4-wire (LN+LL)					

Undervoltage1 Line to Neutral				Conformity Range		Possible Range	
ID		Default		Min	Max	Min	Max
.023	ULN < off	U _{THR} OFF	%Unom	80	10	100	10
.024	ULN < on	U _{THR} ON	%Unom	95	95	95	10
.025	T ULN <	Time OFF	ms	1500	1500	2400	50
Comment:		ULN < on has a fixed offset of 0.5% U _{NOM} added to the displayed value					
Only active for:		Connection Modes: 2-wire, 4-wire (LN), 4-wire (LN+LL)					

Overvoltage2 Line to Line				Conformity Range		Possible Range	
ID		Default		Min	Max	Min	Max
.027	ULL >> off	U _{THR} OFF	%Unom	125	100	130	100
		U _{THR} ON	%Unom	Fixed Hysteresis (1% U _{NOM})			
.029	T ULL >>	Time OFF	ms	100	100	100	10000
Only active for:		Connection Modes: 3-wire, 4-wire (LN+LL)					

Undervoltage2 Line to Line				Conformity Range		Possible Range		
ID				Default	Min	Max	Min	Max
.031	ULL << off	U _{THR} OFF	%Unom	30	10	100	10	100
.032	ULL << on	U _{THR} ON	%Unom	95	95	95	10	100
.033	T ULL <<	Time OFF	ms	800	800	800	50	60000
Only active for:		Connection Modes: 3-wire, 4-wire (LN+LL)						
Comment:		ULL << on has a fixed offset of 0.5% U _{NOM} added to the displayed value						

Overvoltage2 Line to Neutral				Conformity Range		Possible Range		
ID				Default	Min	Max	Min	Max
.035	ULN >> off	U _{THR} OFF	%Unom	125	100	130	100	135
		U _{THR} ON	%Unom	Fixed Hysteresis (1% U _{NOM})				
.037	T ULN >>	Time OFF	ms	100	100	100	100	10000
Only active for:		Connection Modes: 2-wire, 4-wire (LN), 4-wire (LN+LL)						

Undervoltage2 Line to Neutral				Conformity Range		Possible Range		
ID				Default	Min	Max	Min	Max
.039	ULN << off	U _{THR} OFF	%Unom	30	10	100	10	100
.040	ULN << on	U _{THR} ON	%Unom	95	95	95	10	100
.041	T ULN <<	Time OFF	ms	800	800	800	50	60000
Only active for:		Connection Modes: 2-wire, 4-wire (LN), 4-wire (LN+LL)						
Comment:		ULN << on has a fixed offset of 0.5% U _{NOM} added to the displayed value						

Overfrequency1				Conformity Range		Possible Range		
ID				Default	Min	Max	Min	Max
.055	f > off	f _{THR} OFF	Hz	51.50	50.00	55.00	50.00	55.00
.056	f > on	f _{THR} ON	Hz	50.10	50.10	50.10	50.00	55.00
.057	T f >	Time OFF	ms	5000	150	5000	150	10000
Comment:		f > on has a fixed offset of 0.01 Hz subtracted to the displayed value						

Underfrequency1				Conformity Range		Possible Range		
ID				Default	Min	Max	Min	Max
.059	f < off	f _{THR} OFF	Hz	47.50	45.00	50.00	45.00	50.00
.060	f < on	f _{THR} ON	Hz	49.90	49.90	49.90	45.00	50.00
.061	T f <	Time OFF	ms	50	50	70	50	10000
Comment:		f < off has a fixed offset of 0.01 Hz added to the displayed value f < on has a fixed offset of 0.01 Hz added to the displayed value						

Overfrequency2				Conformity Range		Possible Range		
ID				Default	Min	Max	Min	Max
.063	f >> off	f _{THR} OFF	Hz	52.50	50.00	55.00	50.00	55.00
.064	f >> on	f _{THR} ON	Hz	50.10	50.10	50.10	50.00	55.00
.065	T f >>	Time OFF	ms	50	50	70	50	10000
Comment:		f >> off has a fixed offset of 0.01 Hz subtracted to the displayed value						

Frequency measuring in general				Conformity Range		Possible Range		
ID				Default	Min	Max	Min	Max
.113	F wnd	Window length	ms	Fixed window length 100ms				

Auxiliary Contact type				Conformity Range		Possible Range		
ID			Default		Min	Max	Min	Max
.099	Contact	Type	dis. (disabled)		n.o. (normally opened)		n.o. (normally opened)	
					n.c. (normally closed)		n.c. (normally closed)	
					dis. (disabled)		dis. (disabled)	
.100	T Contact	Time OFF	ms	Fixed to 500ms				
.114	I3 STOP	Type	n.o. (normally opened)		n.o. (normally opened)		n.o. (normally opened)	
					n.c. (normally closed)		n.c. (normally closed)	
					dis. (disabled)		dis. (disabled)	

Turn-on delay				Conformity Range		Possible Range		
ID			Default	Min	Max	Min	Max	
.102	Ton delay	Turn on time	s	60	0	600	0	600

Password					Min	Max
ID				Default		
.106	PW1	1 st digit of Password		0	0	9
.107	PW2	2 nd digit of Password		0	0	9
.108	PW3	3 rd digit of Password		0	0	9
.109	PW4	4 th digit of Password		0	0	9
Remark:		If all 4 digits of the Password are 0 (default setting) the Password request is skipped				

Device Information		
ID		
.105	ID: xxxxxx	xxxxx = Device ID
	SW: aa.dd.ccb	dd: Software version of Display Software aa: Software version of Measuring Software cc: Index of Configuration set b: Version of Configuration set

10.21 CEI 0-21:2019 [ID 102]

Connection Mode			Conformity Range		Possible Range	
ID		Default				
.003	Connection	4-wire (LN)	2-wire, 3-wire, 4-wire (LN)		2-wire, 3-wire, 4-wire (LN), 4-wire (LN+LL)	

Nominal Voltage				Conformity Range		Possible Range	
ID		Default		Min	Max	Min	Max
.005	ULN/LL nom	Unom Y Unom Δ	V V	Fixed to 230.0 / 400.0			

Functional Safety			Conformity Range		Possible Range	
ID		Default				
.007	Errtol	Fixed to 1ch				
Remark:		1ch means: 1 channel without functional safety and 1 auxilliary contact1 necessary				

Operational Mode			Conformity Range		Possible Range	
ID		Default				
.009	Mode	1 (transitory)	0 (definitive), 1 (transitory)		0 (definitive), 1 (transitory)	

Overvoltage1 Line to Line				Conformity Range		Possible Range		
ID		Default		Min	Max	Min	Max	
.011	V 59.S2 LL	U _{THR} OFF	%Unom	115	100	130	100	135
		U _{THR} ON	%Unom	Fixed Hysteresis (4% U _{THR})				
.013	T 59.S2 LL	Time OFF	ms	200	50	1000	50	10000
Only active for:		Connection Modes: 3-wire, 4-wire (LN+LL)						

Undervoltage1 Line to Line				Conformity Range		Possible Range		
ID		Default		Min	Max	Min	Max	
.015	V 27.S1 LL	U _{THR} OFF	%Unom	85	20	100	0	100
		U _{THR} ON	%Unom	Fixed Hysteresis (4% U _{THR})				
.017	T 27.S1 LL	Time OFF	ms	1500	50	5000	50	10000
Only active for:		Connection Modes: 3-wire, 4-wire (LN+LL)						

Overvoltage1 Line to Neutral				Conformity Range		Possible Range		
ID		Default		Min	Max	Min	Max	
.019	V 59.S2 LN	U _{THR} OFF	%Unom	115	100	130	100	135
		U _{THR} ON	%Unom	Fixed Hysteresis (4% U _{THR})				
.021	T 59.S2 LN	Time OFF	ms	200	50	1000	50	10000
Only active for:		Connection Modes: 2-wire, 4-wire (LN), 4-wire (LN+LL)						

Undervoltage1 Line to Neutral				Conformity Range		Possible Range		
ID		Default		Min	Max	Min	Max	
.023	V 27.S1 LN	U _{THR} OFF	%Unom	85	20	100	0	100
		U _{THR} ON	%Unom	Fixed Hysteresis (4% U _{THR})				
.025	T 27.S1 LN	Time OFF	ms	1500	50	5000	50	10000
Only active for:		Connection Modes: 2-wire, 4-wire (LN), 4-wire (LN+LL)						

Undervoltage2 Line to Line				Conformity Range		Possible Range		
ID		Default		Min	Max	Min	Max	
.031	V 27.S2 LL	U _{THR} OFF	%Unom	15	5	100	0	100
		U _{THR} ON	%Unom	Fixed Hysteresis (4% U _{THR})				
.033	T 27.S2 LL	Time OFF	ms	200	50	5000	50	10000
Only active for:		Connection Modes: 3-wire, 4-wire (LN+LL)						

Undervoltage2 Line to Neutral				Conformity Range		Possible Range		
ID				Default	Min	Max	Min	Max
.039	V 27.S2 LN	U _{THR} OFF	%Unom	15	5	100	0	100
		U _{THR} ON	%Unom	Fixed Hysteresis (4% U _{THR})				
.041	T 27.S2 LN	Time OFF	ms	200	50	5000	50	10000
Only active for:		Connection Modes: 2-wire, 4-wire (LN), 4-wire (LN+LL)						

10 minutes average overvoltage				Conformity Range		Possible Range		
ID				Default	Min	Max	Min	Max
.043	V 59.S1	U _{THR} OFF	%Unom	110	100	120	100	135
		U _{THR} ON	%Unom	Fixed Hysteresis (4% U _{THR})				
.045	T 59.S1	Time OFF	ms	0	0	0	0	10000

Overfrequency1				Conformity Range		Possible Range		
ID				Default	Min	Max	Min	Max
.055	F 81>S2 ws	f _{THR} OFF	Hz	51.50	50.00	52.00	50.00	55.00
		f _{THR} ON	Hz	Fixed Hysteresis (0.2% f _{THR})				
.057	T 81>S2 ws	Time OFF	ms	1000	50	5000	50	10000
Only active for:		Operational Mode 0 (definitive mode) when DigIn4 is inactive (contact open) Voltage > 20% U _{NOM}						

Underfrequency1				Conformity Range		Possible Range		
ID				Default	Min	Max	Min	Max
.059	F 81<S2 ws	f _{THR} OFF	Hz	47.50	47.00	50.00	45.00	50.00
		f _{THR} ON	Hz	Fixed Hysteresis (0.2% f _{THR})				
.061	T 81<S2 ws	Time OFF	ms	4000	50	5000	50	10000
Only active for:		Operational Mode 0 (definitive mode) when DigIn4 is inactive (contact open) Voltage > 20% U _{NOM}						

Overfrequency2				Conformity Range		Possible Range		
ID				Default	Min	Max	Min	Max
.063	F 81>S1 nf	f _{THR} OFF	Hz	50.20	50.00	52.00	50.00	55.00
		f _{THR} ON	Hz	Fixed Hysteresis (0.2% f _{THR})				
.065	T 81>S1 nf	Time OFF	ms	100	50	5000	50	10000
Only active for:		Operational Mode 0 (definitive mode) when DigIn4 is active (contact closed) Operational Mode 1 (transitory mode) when DigIn5 is active (contact closed) Voltage > 20% U _{NOM}						

Underfrequency2				Conformity Range		Possible Range		
ID				Default	Min	Max	Min	Max
.067	F 81<S1 nf	f _{THR} OFF	Hz	49.80	47.00	50.00	45.00	50.00
		f _{THR} ON	Hz	Fixed Hysteresis (0.2% f _{THR})				
.069	T 81<S1 nf	Time OFF	ms	100	50	5000	50	10000
Only active for:		Operational Mode 0 (definitive mode) when DigIn4 is active (contact closed) Operational Mode 1 (transitory mode) when DigIn5 is active (contact closed) Voltage > 20% U _{NOM}						

Overfrequency3				Conformity Range		Possible Range		
ID				Default	Min	Max	Min	Max
.071	F 81>S2 wf	f _{THR} OFF	Hz	51.50	50.00	52.00	50.00	55.00
		f _{THR} ON	Hz	Fixed Hysteresis (0.2% f _{THR})				
.073	T 81>S2 wf	Time OFF	ms	100	50	5000	50	10000
Only active for:		Operational Mode 1 (transitory mode) when DigIn5 is inactive (contact open) Voltage > 20% U _{NOM}						

Underfrequency3					Conformity Range		Possible Range	
ID				Default	Min	Max	Min	Max
.075	F 81<S2 wf	f _{THR} OFF	Hz	47.50	47.00	50.00	45.00	50.00
		f _{THR} ON	Hz	Fixed Hysteresis (0.2% f _{THR})				
.077	T 81<S2 wf	Time OFF	ms	100	50	5000	50	10000
Only active for:		Operational Mode 1 (transitory mode) when DigIn5 is inactive (contact open) Voltage > 20% U _{NOM}						

Frequency measuring in general				Conformity Range		Possible Range		
ID				Default	Min	Max	Min	Max
.113	F wnd	Window length	ms	Fixed window length 100ms				

Rate of Change of Frequency (RoCoF)				Conformity Range		Possible Range		
ID				Default	Min	Max	Min	Max
.090	RoCoF	Enable Function		off	on / off		on / off	
.091	RoCoF OFF	RoCoF _{THR} OFF	mHz/s	2700	1000	4000	100	8000
.092	RoCoF ON	RoCoF _{THR} ON	mHz/s	2300	1000	4000	100	8000
.093	T RoCoF	Time OFF	ms	0	0	1000	0	10000
.111	RoCoF wnd	Window length	ms	100	100	1000	100	1000

Auxiliary Contact type				Conformity Range		Possible Range		
ID				Default	Min	Max	Min	Max
.099	Contact	Type	n.c. (normally closed)		n.o. (normally opened) n.c. (normally closed)		n.o. (normally opened) n.c. (normally closed) dis. (disabled)	
.100	T Contact	Time OFF	ms	Fixed to 500ms				
.114	I3 STOP	Type	n.o. (normally opened)		n.o. (normally opened)		n.o. (normally opened) n.c. (normally closed) dis. (disabled)	

Turn-on delay				Conformity Range		Possible Range		
ID				Default	Min	Max	Min	Max
.102	Ton delay	Turn on time	s	5	0	300	0	600

Password					Default	Min	Max
ID							
.106	PW1	1 st digit of Password			0	0	9
.107	PW2	2 nd digit of Password			0	0	9
.108	PW3	3 rd digit of Password			0	0	9
.109	PW4	4 th digit of Password			0	0	9
Remark:		If all 4 digits of the Password are 0 (default setting) the Password request is skipped					

Device Information		
ID		
.105	ID: xxxxxx SW: aa.dd.ccb	xxxxx = Device ID dd: Software version of Display Software aa: Software version of Measuring Software cc: Index of Configuration set b: Version of Configuration set

10.22 G99/1/3:2018 LV [ID 410]

Connection Mode			Conformity Range		Possible Range	
ID		Default				
.003	Connection	Fixed to 4-wire (LN)				

Nominal Voltage				Conformity Range		Possible Range		
ID			Default	Min	Max	Min	Max	
.005	ULN/LL nom	Unom Y	V	230.0	230.0	240.0	100.0	240.0
		Unom Δ	V	400.0	400.0	417.4	173.9	417.4

Functional Safety			Conformity Range		Possible Range	
ID		Default				
.007	Errtol	Fixed to 1ch				
Remark:		1ch means: 1 channel without functional safety and 1 auxilliary contact1 necessary				

Overvoltage1 Line to Neutral				Conformity Range		Possible Range		
ID			Default	Min	Max	Min	Max	
.019	O/V st 1	U _{THR} OFF	%Unom	114	114	114	100	135
		U _{THR} ON	%Unom	Fixed Hysteresis (0.75% U _{NOM})				
.021	T O/V st 1	Time OFF	ms	1000	1000	1000	50	300000

Overvoltage2 Line to Neutral				Conformity Range		Possible Range		
ID			Default	Min	Max	Min	Max	
.035	O/V st 2	U _{THR} OFF	%Unom	119	119	119	100	135
		U _{THR} ON	%Unom	Fixed Hysteresis (0.75% U _{NOM})				
.037	T O/V st 2	Time OFF	ms	500	500	500	50	300000

Undervoltage2 Line to Neutral				Conformity Range		Possible Range		
ID			Default	Min	Max	Min	Max	
.039	U/V	U _{THR} OFF	%Unom	80	80	80	0	100
		U _{THR} ON	%Unom	Fixed Hysteresis (0.75% U _{NOM})				
.041	T U/V	Time OFF	ms	2500	2500	2500	50	300000

Underfrequency1				Conformity Range		Possible Range		
ID			Default	Min	Max	Min	Max	
.059	U/F st 1	f _{THR} OFF	Hz	47.50	47.50	47.50	40.00	50.00
		f _{THR} ON	Hz	Fixed Hysteresis (0.05 Hz)				
.061	T U/F st 1	Time OFF	ms	20000	20000	20000	1000	300000

Overfrequency2				Conformity Range		Possible Range		
ID			Default	Min	Max	Min	Max	
.063	O/F	f _{THR} OFF	Hz	52.00	52.00	52.00	50.00	55.00
		f _{THR} ON	Hz	Fixed Hysteresis (0.05 Hz)				
.065	T O/F	Time OFF	ms	500	500	500	50	300000

Underfrequency2				Conformity Range		Possible Range		
ID			Default	Min	Max	Min	Max	
.067	U/F st 2	f _{THR} OFF	Hz	47.00	47.00	47.00	40.00	50.00
		f _{THR} ON	Hz	Fixed Hysteresis (0.05 Hz)				
.069	T U/F st 2	Time OFF	ms	500	500	500	50	300000

Frequency measuring in general				Conformity Range		Possible Range	
ID			Default	Min	Max	Min	Max
.113	F wnd	Window length	ms	Fixed window length 100ms			

Rate of Change of Frequency (RoCoF)				Conformity Range		Possible Range		
ID				Default	Min	Max	Min	Max
.090	RoCoF	Enable Function		on	on / off		on / off	
.091	RoCoF off	RoCoF _{THR} OFF	mHz/s	1000	10	3000	10	3000
.092	RoCoF on	RoCoF _{THR} ON	mHz/s	950	10	3000	10	3000
.093	RoCoFDelay	Time OFF	ms	500	50	500	50	2000
.111	RoCoF wnd	Window length	ms	Fixed window length 225ms				

Phase Shift (PShift)				Conformity Range		Possible Range		
ID				Default	Min	Max	Min	Max
.094	PShift	Enable Function		off	on / off		on / off	
.095	PShift off	PShift _{THR} OFF	°	12	--	--	3	15
.096	PShift on	PShift _{THR} ON	°	9	--	--	3	15
		Time OFF	ms	Fixed to fastest possible disconnection				
.112	PShift wnd	Window length	ms	Fixed window length 200ms				

Auxiliary Contact type				Conformity Range		Possible Range		
ID			Default		Min	Max	Min	Max
.099	Contact	Type	dis. (disabled)		n.o. (normally opened) n.c. (normally closed) dis. (disabled)		n.o. (normally opened) n.c. (normally closed) dis. (disabled)	
.100	T Contact	Time OFF	ms	Fixed to 500ms				
.114	I3 STOP	Type	n.o. (normally opened)		n.o. (normally opened) n.c. (normally closed) dis. (disabled)		n.o. (normally opened) n.c. (normally closed) dis. (disabled)	

Turn-on delay				Conformity Range		Possible Range		
ID				Default	Min	Max	Min	Max
.102	Ton delay	Turn on time	s	20	20	20	0	600

Password						
ID				Default	Min	Max
.106	PW1	1 st digit of Password		0	0	9
.107	PW2	2 nd digit of Password		0	0	9
.108	PW3	3 rd digit of Password		0	0	9
.109	PW4	4 th digit of Password		0	0	9
Remark:		If all 4 digits of the Password are 0 (default setting) the Password request is skipped				

Device Information		
ID		
.105	ID: xxxxxx SW: aa.dd.ccb	xxxxx = Device ID dd: Software version of Display Software aa: Software version of Measuring Software cc: Index of Configuration set b: Version of Configuration set

10.23 G99/1/3:2018 HV [ID 460]

Connection Mode			Conformity Range		Possible Range	
ID		Default				
.003	Connection	Fixed to 3-wire				

Nominal Voltage				Conformity Range		Possible Range		
ID			Default	Min	Max	Min	Max	
.005	ULN/LL nom	Unom Y	V	230.0	57.5	230.0	28.8	241.4
		Unom Δ	V	400.0	100.0	400	50.0	420.0

Functional Safety			Conformity Range		Possible Range	
ID		Default				
.007	Errtol	Fixed to 1ch				
Remark:		1ch means: 1 channel without functional safety and 1 auxilliary contact1 necessary				

Overvoltage1 Line to Line				Conformity Range		Possible Range		
ID			Default	Min	Max	Min	Max	
.011	O/V st 1	U _{THR} OFF	%Unom	110	110	110	100	135
		U _{THR} ON	%Unom	Fixed Hysteresis (0.75% U _{NOM})				
.013	T O/V st 1	Time OFF	ms	1000	1000	1000	50	300000

Overvoltage2 Line to Line				Conformity Range		Possible Range		
ID			Default	Min	Max	Min	Max	
.027	O/V st 2	U _{THR} OFF	%Unom	113	113	113	100	135
		U _{THR} ON	%Unom	Fixed Hysteresis (0.75% U _{NOM})				
.029	T O/V st 2	Time OFF	ms	500	500	500	50	300000

Undervoltage2 Line to Line				Conformity Range		Possible Range		
ID			Default	Min	Max	Min	Max	
.031	U/V	U _{THR} OFF	%Unom	80	80	80	0	100
		U _{THR} ON	%Unom	Fixed Hysteresis (0.75% U _{NOM})				
.033	T U/V	Time OFF	ms	2500	2500	2500	50	300000

Underfrequency1				Conformity Range		Possible Range		
ID			Default	Min	Max	Min	Max	
.059	U/F st 1	f _{THR} OFF	Hz	47.50	47.50	47.50	40.00	50.00
		f _{THR} ON	Hz	Fixed Hysteresis (0.05 Hz)				
.061	T U/F st 1	Time OFF	ms	20000	20000	20000	1000	300000

Overfrequency2				Conformity Range		Possible Range		
ID			Default	Min	Max	Min	Max	
.063	O/F	f _{THR} OFF	Hz	52.00	52.00	52.00	50.00	55.00
		f _{THR} ON	Hz	Fixed Hysteresis (0.05 Hz)				
.065	T O/F	Time OFF	ms	500	500	500	50	300000

Underfrequency2				Conformity Range		Possible Range		
ID			Default	Min	Max	Min	Max	
.067	U/F st 2	f _{THR} OFF	Hz	47.00	47.00	47.00	40.00	50.00
		f _{THR} ON	Hz	Fixed Hysteresis (0.05 Hz)				
.069	T U/F st 2	Time OFF	ms	500	500	500	50	300000

Frequency measuring in general				Conformity Range		Possible Range	
ID			Default	Min	Max	Min	Max
.113	F wnd	Window length	ms	Fixed window length 100ms			

Rate of Change of Frequency (RoCoF)				Conformity Range		Possible Range		
ID				Default	Min	Max	Min	Max
.090	RoCoF	Enable Function		on	on / off		on / off	
.091	RoCoF off	RoCoF _{THR} OFF	mHz/s	1000	10	3000	10	3000
.092	RoCoF on	RoCoF _{THR} ON	mHz/s	950	10	3000	10	3000
.093	RoCoFDelay	Time OFF	ms	500	50	500	50	2000
.111	RoCoF wnd	Window length	ms	Fixed window length 225ms				

Phase Shift (PShift)				Conformity Range		Possible Range		
ID				Default	Min	Max	Min	Max
.094	PShift	Enable Function		off	on / off		on / off	
.095	PShift off	PShift _{THR} OFF	°	12	--	--	3	15
.096	PShift on	PShift _{THR} ON	°	9	--	--	3	15
		Time OFF	ms	Fixed to fastest possible disconnection				
.112	PShift wnd	Window length	ms	Fixed window length 200ms				

Auxiliary Contact type				Conformity Range		Possible Range		
ID				Default	Min	Max	Min	Max
.099	Contact	Type	dis. (disabled)		n.o. (normally opened) n.c. (normally closed) dis. (disabled)		n.o. (normally opened) n.c. (normally closed) dis. (disabled)	
.100	T Contact	Time OFF	ms	Fixed to 500ms				
.114	I3 STOP	Type	n.o. (normally opened)		n.o. (normally opened) n.c. (normally closed) dis. (disabled)		n.o. (normally opened) n.c. (normally closed) dis. (disabled)	
.100	T Contact	Time OFF	ms	Fixed to 500ms				

Turn-on delay				Conformity Range		Possible Range		
ID				Default	Min	Max	Min	Max
.102	Ton delay	Turn on time	s	20	20	20	0	600

Password							
ID				Default	Min	Max	
.106	PW1	1 st digit of Password			0	0	9
.107	PW2	2 nd digit of Password			0	0	9
.108	PW3	3 rd digit of Password			0	0	9
.109	PW4	4 th digit of Password			0	0	9
Remark:		If all 4 digits of the Password are 0 (default setting) the Password request is skipped					

Device Information		
ID		
.105	ID: xxxxxx SW: aa.dd.ccb	xxxxx = Device ID dd: Software version of Display Software aa: Software version of Measuring Software cc: Index of Configuration set b: Version of Configuration set

10.24 G98/1/2:2018 [ID 510]

Connection Mode			Conformity Range		Possible Range	
ID		Default				
.003	Connection	Fixed to 4-wire (LN)				

Nominal Voltage				Conformity Range		Possible Range		
ID			Default	Min	Max	Min	Max	
.005	ULN/LL nom	Unom Y	V	230.0	230.0	240.0	100.0	240.0
		Unom Δ	V	400.0	400.0	417.4	173.9	417.4

Functional Safety			Conformity Range		Possible Range	
ID		Default				
.007	Errtol	Fixed to 1ch				
Remark:		1ch means: 1 channel without functional safety and 1 auxilliary contact1 necessary				

Overvoltage1 Line to Neutral				Conformity Range		Possible Range		
ID			Default	Min	Max	Min	Max	
.019	O/V st 1	U _{THR} OFF	%Unom	114	114	114	100	135
		U _{THR} ON	%Unom	Fixed Hysteresis (0.75% U _{NOM})				
.021	T O/V st 1	Time OFF	ms	1000	1000	1000	50	10000

Overvoltage2 Line to Neutral				Conformity Range		Possible Range		
ID			Default	Min	Max	Min	Max	
.035	O/V st 2	U _{THR} OFF	%Unom	119	119	119	100	135
		U _{THR} ON	%Unom	Fixed Hysteresis (0.75% U _{NOM})				
.037	T O/V st 2	Time OFF	ms	500	500	500	50	10000

Undervoltage2 Line to Neutral				Conformity Range		Possible Range		
ID			Default	Min	Max	Min	Max	
.039	U/V	U _{THR} OFF	%Unom	80	80	80	0	100
		U _{THR} ON	%Unom	Fixed Hysteresis (0.75% U _{NOM})				
.041	T U/V	Time OFF	ms	2500	2500	2500	50	10000

Underfrequency1				Conformity Range		Possible Range		
ID			Default	Min	Max	Min	Max	
.059	U/F st 1	f _{THR} OFF	Hz	47.50	47.50	47.50	40.00	50.00
		f _{THR} ON	Hz	Fixed Hysteresis (0.05 Hz)				
.061	T U/F st 1	Time OFF	ms	20000	20000	20000	1000	120000

Overfrequency2				Conformity Range		Possible Range		
ID			Default	Min	Max	Min	Max	
.063	O/F	f _{THR} OFF	Hz	52.00	52.00	52.00	50.00	55.00
		f _{THR} ON	Hz	Fixed Hysteresis (0.05 Hz)				
.065	T O/F	Time OFF	ms	500	500	500	50	10000

Underfrequency2				Conformity Range		Possible Range		
ID			Default	Min	Max	Min	Max	
.067	U/F st 2	f _{THR} OFF	Hz	47.00	47.00	47.00	40.00	50.00
		f _{THR} ON	Hz	Fixed Hysteresis (0.05 Hz)				
.069	T U/F st 2	Time OFF	ms	500	500	500	50	10000

Frequency measuring in general				Conformity Range		Possible Range	
ID			Default	Min	Max	Min	Max
.113	F wnd	Window length	ms	Fixed window length 100ms			

Rate of Change of Frequency (RoCoF)				Conformity Range		Possible Range		
ID				Default	Min	Max	Min	Max
.090	RoCoF	Enable Function		on	on / off		on / off	
.091	RoCoF off	RoCoF _{THR} OFF	mHz/s	1000	10	3000	10	3000
.092	RoCoF on	RoCoF _{THR} ON	mHz/s	950	10	3000	10	3000
		Time OFF	ms	Fixed to fastest possible disconnection				
.111	RoCoF wnd	Window length	ms	Fixed window length 535ms				

Phase Shift (PShift)				Conformity Range		Possible Range		
ID				Default	Min	Max	Min	Max
.094	PShift	Enable Function		off	on / off		on / off	
.095	PShift off	PShift _{THR} OFF	°	12	--	--	3	15
.096	PShift on	PShift _{THR} ON	°	9	--	--	3	15
		Time OFF	ms	Fixed to the fastest possible disconnection				
.112	PShift wnd	Window length	ms	Fixed window length 200ms				

Auxiliary Contact type				Conformity Range		Possible Range		
ID			Default		Min	Max	Min	Max
.099	Contact	Type	dis. (disabled)		n.o. (normally opened) n.c. (normally closed) dis. (disabled)		n.o. (normally opened) n.c. (normally closed) dis. (disabled)	
.100	T Contact	Time OFF	ms	Fixed to 500ms				
.114	I3 STOP	Type	n.o. (normally opened)		n.o. (normally opened) n.c. (normally closed) dis. (disabled)		n.o. (normally opened) n.c. (normally closed) dis. (disabled)	

Turn-on delay				Conformity Range		Possible Range		
ID				Default	Min	Max	Min	Max
.102	Ton delay	Turn on time	s	20	20	20	0	600

Password						
ID				Default	Min	Max
.106	PW1	1 st digit of Password		0	0	9
.107	PW2	2 nd digit of Password		0	0	9
.108	PW3	3 rd digit of Password		0	0	9
.109	PW4	4 th digit of Password		0	0	9
Remark:		If all 4 digits of the Password are 0 (default setting) the Password request is skipped				

Device Information		
ID		
.105	ID: xxxxxx SW: aa.dd.ccb	xxxxx = Device ID dd: Software version of Display Software aa: Software version of Measuring Software cc: Index of Configuration set b: Version of Configuration set

10.25 C10-11:2021 LV-IP [ID 603] Interface Protection low voltage

Connection Mode			Conformity Range	Possible Range
ID		Default		
.003	Connection	4-wire (LN+LL)	4-wire (LN+LL)	2-wire, 3-wire, 4-wire (LN), 4-wire (LN+LL)

Nominal Voltage				Conformity Range		Possible Range		
ID			Default	Min	Max	Min	Max	
.005	ULN/LL nom	Unom Y	V	230.0	230.0	240.0	100.0	240.0
		Unom Δ	V	400.0	400.0	417.4	173.9	417.4

Functional Safety			Conformity Range	Possible Range
ID		Default		
.007	Errtol	Fixed to 1ch		
Remark:		1ch means: 1 channel without functional safety and 1 auxilliary contact necessary		

Overvoltage1 Line to Neutral				Conformity Range		Possible Range		
ID			Default	Min	Max	Min	Max	
.019	U LN > off	U _{THR} OFF	%Unom	110	100	110	100	135
.020	U LN > on	U _{THR} ON	%Unom	109	100	120	100	135
.021	T U LN >	Time OFF	ms	1000	0	3000	0	10000
Comment:		U LN > off has a fixed offset of 0.25% U _{NOM} subtracted from the displayed value						
Only active for:		Connection Modes: 2-wire, 4-wire (LN), 4-wire (LN+LL)						

Undervoltage1 Line to Neutral				Conformity Range		Possible Range		
ID			Default	Min	Max	Min	Max	
.023	U LN < off	U _{THR} OFF	%Unom	70	50	85	0	100
.024	U LN < on	U _{THR} ON	%Unom	85	50	100	0	100
.025	T U LN <	Time OFF	ms	1500	0	1500	0	10000
Comment:		U LN < off has a fixed offset of 0.25% U _{NOM} added to the displayed value						
Only active for:		Connection Modes: 2-wire, 4-wire (LN), 4-wire (LN+LL)						

Overvoltage2 Line to Neutral				Conformity Range		Possible Range		
ID			Default	Min	Max	Min	Max	
.035	U LN>> off	U _{THR} OFF	%Unom	115	110	130	100	135
.036	U LN>> on	U _{THR} ON	%Unom	114	100	120	100	135
.037	T ULN>>	Time OFF	ms	0	0	0	0	10000
		Time OFF	ms	Fixed to fastest possible disconnection				
Comment:		U LN > off has a fixed offset of 0.25% U _{NOM} subtracted from the displayed value						
Only active for:		Connection Modes: 2-wire, 4-wire (LN), 4-wire (LN+LL)						

Undervoltage2 Line to Neutral				Conformity Range		Possible Range		
ID			Default	Min	Max	Min	Max	
.039	U LN<< off	U _{THR} OFF	%Unom	15	15	50	0	100
.040	U LN<< on	U _{THR} ON	%Unom	85	50	100	0	100
.041	T U LN<<	Time OFF	ms	250	0	5000	0	10000
Comment:		U LN < off has a fixed offset of 0.25% U _{NOM} added to the displayed value						
Only active for:		Connection Modes: 2-wire, 4-wire (LN), 4-wire (LN+LL)						

Zero Voltage Line to Neutral				Conformity Range		Possible Range		
ID				Default	Min	Max	Min	Max
.115	Uzero >	Enable Function		on	on		on/off	
.116	Uzero> off	U _{THR} OFF	%Unom	20	20	20	5	100
.117	Uzero> on	U _{THR} ON	%Unom	15	1	19	1	100
.118	T Uzero >	Time OFF	ms	1500	0	1500	0	10000
Only active for:		Connection Modes: 4-wire (LN+LL)						

Residual Voltage (3 x Zero Voltage) Line to Neutral Activation of a narrower frequency window				Conformity Range		Possible Range		
ID				Default	Min	Max	Min	Max
.119	Ures-anfw>	Enable Function		on	on		on/off	
.120	Ures > on	U _{THR} OFF	%Unom	5	5	5	2	100
.121	Ures > off	U _{THR} ON	%Unom	3	1	3	1	100
.122	T Ures >	Time OFF	ms	200	0	240000	0	240000
Only active for:		Connection Modes: 4-wire (LN+LL)						

Undervoltage Line to Neutral Activation of a narrower frequency window				Conformity Range		Possible Range		
ID				Default	Min	Max	Min	Max
.123	Uanfw <	Enable Function		on	on		on/off	
.124	Uanfw< on	U _{THR} OFF	%Unom	85	85	85	1	100
.125	Uanfw< off	U _{THR} ON	%Unom	86	86	100	2	100
.126	T Uanfw <	Time OFF	ms	0	0	240000	0	240000
Only active for:		Connection Modes: 4-wire (LN+LL)						

Overfrequency1				Conformity Range		Possible Range		
ID				Default	Min	Max	Min	Max
.055	f > off	f _{THR} OFF	Hz	51.50	51.50	51.50	50.00	55.00
.056	f > on	f _{THR} ON	Hz	50.10	50.00	52.00	50.00	55.00
.057	T f >	Time OFF	ms	0	0	0	0	10000
Comment:		f > off has a fixed offset of 0.01 Hz subtracted to the displayed value						
Only active for:		Voltage > 20% U _{NOM}						

Underfrequency1				Conformity Range		Possible Range		
ID				Default	Min	Max	Min	Max
.059	f < off	f _{THR} OFF	Hz	47.50	47.50	47.50	40.00	50.00
.060	f < on	f _{THR} ON	Hz	49.90	47.00	50.00	40.00	50.00
.061	T f <	Time OFF	ms	0	0	0	0	10000
Comment:		f < off has a fixed offset of 0.01 Hz added to the displayed value						
Only active for:		Voltage > 20% U _{NOM}						

Overfrequency nw (narrower window)				Conformity Range		Possible Range		
ID				Default	Min	Max	Min	Max
.062	f nw >	Enable Function		on	on		on/off	
.063	f nw > off	f _{THR} OFF	Hz	50.30	50.30	50.30	50.00	55.00
.064	f nw > on	f _{THR} ON	Hz	50.10	50.00	52.00	50.00	55.00
.065	T f nw >	Time OFF	ms	500	500	500	0	10000
Comment:		f nw > off has a fixed offset of 0.01 Hz subtracted to the displayed value						
Only active for:		Ures-anfw, Uanfw, Dig Input5=HIGH (local setting)						

Underfrequency nw (narrower window)				Conformity Range		Possible Range		
ID				Default	Min	Max	Min	Max
.066	f nw <	Enable Function		on	on		on/off	
.067	f nw < off	f _{THR} OFF	Hz	49.70	49.70	49.70	45.00	50.00
.068	f nw < on	f _{THR} ON	Hz	49.90	47.00	50.00	45.00	50.00
.069	T f nw <	Time OFF	ms	500	500	500	0	10000
Comment:		f nw < off has a fixed offset of 0.01 Hz added to the displayed value						
Only active for:		Ures-anfw, Uanfw, Dig Input5=HIGH (local setting)						

Frequency measuring in general				Conformity Range		Possible Range		
ID				Default	Min	Max	Min	Max
.113	F wnd	Window length	ms	Fixed window length 100ms				

Rate of Change of Frequency (RoCoF)				Conformity Range		Possible Range		
ID				Default	Min	Max	Min	Max
.090	RoCoF	Enable Function		on	on / off		on / off	
.091	RoCoF off	RoCoF _{THR} OFF	mHz/s	1000	1000	2000	100	5000
.092	RoCoF on	RoCoF _{THR} ON	mHz/s	800	100	2000	100	5000
.093	RoCoF t	Time OFF	ms	0	0	0	0	5000
.111	RoCoF wnd	Window length	ms	Fixed window length 100ms				

Phase Shift (PShift)				Conformity Range		Possible Range		
ID				Default	Min	Max	Min	Max
.094	PShift	Enable Function		off	on / off		on / off	
.095	PShift off	PShift _{THR} OFF	°	7	7	7	3	15
.096	PShift on	PShift _{THR} ON	°	5	3	7	3	15
		Time OFF	ms	Fixed to the fastest possible disconnection				
.112	PShift wnd	Window length	ms	Fixed window length 100ms				
Comment:		PShift off has a fixed offset of 1° subtracted from the displayed value						

Auxiliary Contact type				Conformity Range		Possible Range		
ID				Default	Min	Max	Min	Max
.099	Contact	Type	dis. (disabled)		n.o. (normally opened) n.c. (normally closed) dis. (disabled)		n.o. (normally opened) n.c. (normally closed) dis. (disabled)	
.100	Contact t	Time OFF	ms	300	100	300	10	5000
.114	I3 STOP	Type	n.o. (normally opened)		n.o. (normally opened) n.c. (normally closed) dis. (disabled)		n.o. (normally opened) n.c. (normally closed) dis. (disabled)	

Turn-on delay				Conformity Range		Possible Range		
ID				Default	Min	Max	Min	Max
.102	T on delay	Turn on time	s	60	60	60	0	600

Password				Default	Min	Max
ID						
.106	PW1	1 st digit of Password		0	0	9
.107	PW2	2 nd digit of Password		0	0	9
.108	PW3	3 rd digit of Password		0	0	9
.109	PW4	4 th digit of Password		0	0	9
Remark:		If all 4 digits of the Password are 0 (default setting) the Password request is skipped				

Device Information		
ID		
.105	ID: xxxxxx SW: aa.dd.ccb	xxxxx = Device ID dd: Software version of Display Software aa: Software version of Measuring Software cc: Index of Configuration set b: Version of Configuration set

10.26 C10-11:2019 LV-ASS [ID 602] Automatic Separation System / Low Voltage

Connection Mode				Conformity Range		Possible Range	
ID		Default					
.003	Connection	4-wire (LN)		4-wire (LN)		2-wire, 3-wire, 4-wire (LN), 4-wire (LN+LL)	

Nominal Voltage				Conformity Range		Possible Range		
ID		Default		Min	Max	Min	Max	
.005	ULN/LL nom	Unom Y	V	230.0	230.0	240.0	100.0	240.0
		Unom Δ	V	400.0	400.0	417.4	173.9	417.4

Functional Safety				Conformity Range		Possible Range	
ID		Default					
.007	Errtol	Fixed to 1ch					
Remark:		1ch means: 1 channel without functional safety and 1 auxilliary contact1 necessary					

Overvoltage1 Line to Neutral				Conformity Range		Possible Range		
ID		Default		Min	Max	Min	Max	
.019	U LN > off	U _{THR} OFF	%Unom	115	100	120	100	135
.020	U LN > on	U _{THR} ON	%Unom	109	100	120	100	135
.021	T U LN >	Time OFF	ms	100	100	100000	100	100000
Comment:		U LN > off has a fixed offset of 0.25% U _{NOM} subtracted from the displayed value						
Only active for:		Connection Modes: 2-wire, 4-wire (LN), 4-wire (LN+LL)						

Undervoltage1 Line to Neutral				Conformity Range		Possible Range		
ID		Default		Min	Max	Min	Max	
.023	U LN < off	U _{THR} OFF	%Unom	80	20	100	0	100
.024	U LN < on	U _{THR} ON	%Unom	85	50	100	0	100
.025	T U LN <	Time OFF	ms	100	100	100000	100	100000
Comment:		U LN < off has a fixed offset of 0.25% U _{NOM} added to the displayed value						
Only active for:		Connection Modes: 2-wire, 4-wire (LN), 4-wire (LN+LL)						

10 minutes average overvoltage				Conformity Range		Possible Range		
ID		Default		Min	Max	Min	Max	
.042	Uavg	Enable function		on		on /off		
.043	Uavg off	U _{THR} OFF	%Unom	110	100	115	100	135
		U _{THR} ON	%Unom	Fixed Hysteresis (1% U _{NOM})				
		Time OFF	ms	Fixed to fastest possible disconnection				

Overfrequency1				Conformity Range		Possible Range		
ID		Default		Min	Max	Min	Max	
.055	f > off	f _{THR} OFF	Hz	51.50	50.00	52.00	50.00	55.00
.056	f > on	f _{THR} ON	Hz	50.10	50.00	52.00	50.00	55.00
		Time OFF	ms	Fixed to fastest possible disconnection				
Comment:		f > off has a fixed offset of 0.01 Hz subtracted to the displayed value						
Only active for:		Voltage > 20% U _{NOM}						

Underfrequency1				Conformity Range		Possible Range		
ID		Default		Min	Max	Min	Max	
.059	f < off	f _{THR} OFF	Hz	47.50	47.00	50.00	40.00	50.00
.060	f < on	f _{THR} ON	Hz	49.90	47.00	50.00	40.00	50.00
		Time OFF	ms	Fixed to fastest possible disconnection				
Comment:		f < off has a fixed offset of 0.01 Hz added to the displayed value						
Only active for:		Voltage > 20% U _{NOM}						

Frequency measuring in general				Conformity Range		Possible Range		
ID				Default	Min	Max	Min	Max
.113	F wnd	Window length	ms	Fixed window length 100ms				

Rate of Change of Frequency (RoCoF)				Conformity Range		Possible Range		
ID				Default	Min	Max	Min	Max
.090	RoCoF	Enable Function		off	on / off		on / off	
.091	RoCoF off	RoCoF _{THR} OFF	mHz/s	1000	1000	1000	100	2000
.092	RoCoF on	RoCoF _{THR} ON	mHz/s	800	100	1000	100	1000
.093	RoCoF t	Time OFF	ms	0	0	0	0	1000
.111	RoCoF wnd	Window length	ms	Fixed window length 100ms				

Phase Shift (PShift)				Conformity Range		Possible Range		
ID				Default	Min	Max	Min	Max
.094	PShift	Enable Function		on	on / off		on / off	
.095	PShift off	PShift _{THR} OFF	°	7	7	7	3	15
.096	PShift on	PShift _{THR} ON	°	5	3	7	3	15
		Time OFF	ms	Fixed to the fastest possible disconnection				
.112	PShift wnd	Window length	ms	Fixed window length 100ms				
Comment:		PShift off has a fixed offset of 1° subtracted from the displayed value						

Auxiliary Contact type				Conformity Range		Possible Range		
ID				Default	Min	Max	Min	Max
.099	Contact	Type		dis. (disabled)	n.o. (normally opened) n.c. (normally closed) dis. (disabled)		n.o. (normally opened) n.c. (normally closed) dis. (disabled)	
.100	Contact t	Time OFF	ms	300	100	300	10	5000
.114	I3 STOP	Type		n.o. (normally opened)	n.o. (normally opened) n.c. (normally closed) dis. (disabled)		n.o. (normally opened) n.c. (normally closed) dis. (disabled)	

Turn-on delay				Conformity Range		Possible Range		
ID				Default	Min	Max	Min	Max
.102	Ton delay	Turn on time	s	60	60	60	0	600

Password				Default	Min	Max
ID						
.106	PW1	1 st digit of Password		0	0	9
.107	PW2	2 nd digit of Password		0	0	9
.108	PW3	3 rd digit of Password		0	0	9
.109	PW4	4 th digit of Password		0	0	9
Remark:		If all 4 digits of the Password are 0 (default setting) the Password request is skipped				

Device Information		
ID		
.105	ID: xxxxxx SW: aa.dd.ccb	xxxxx = Device ID dd: Software version of Display Software aa: Software version of Measuring Software cc: Index of Configuration set b: Version of Configuration set

10.27 C10-11:2021 HV-IP [ID 653] Interface Protection / High Voltage

Connection Mode			Conformity Range		Possible Range	
ID		Default				
.003	Connection	3-wire	3-wire		2-wire, 3-wire, 4-wire (LN), 4-wire (LN+LL)	

Nominal Voltage				Conformity Range		Possible Range		
ID		Default		Min	Max	Min	Max	
.005	ULN/LL nom	Unom Y	V	230.0	57.5	230.0	28.8	241.4
		Unom Δ	V	400.0	100.0	400.0	50.0	420.0

Functional Safety			Conformity Range		Possible Range	
ID		Default				
.007	Errtol	Fixed to 1ch				
Remark:		1ch means: 1 channel without functional safety and 1 auxilliary contact necessary				

Overvoltage1 Line to Line				Conformity Range		Possible Range		
ID		Default		Min	Max	Min	Max	
.011	U LL > off	U _{THR} OFF	%Unom	110	100	110	100	135
.012	U LL > on	U _{THR} ON	%Unom	109	100	120	100	135
.013	T U LL >	Time OFF	ms	1000	0	3000	0	10000
Comment:		U LL > off has a fixed offset of 0.25% U _{NOM} subtracted from the displayed value						
Only active for:		Connection Modes: 3-wire, 4-wire (LN+LL)						

Undervoltage1 Line to Line				Conformity Range		Possible Range		
ID		Default		Min	Max	Min	Max	
.015	U LL < off	U _{THR} OFF	%Unom	70	50	85	0	100
.016	U LL < on	U _{THR} ON	%Unom	90	50	100	0	100
.017	T U LL <	Time OFF	ms	1500	0	1500	0	10000
Comment:		U LL < off has a fixed offset of 0.25% U _{NOM} added to the displayed value						
Only active for:		Connection Modes: 3-wire, 4-wire (LN+LL)						

Overvoltage2 Line to Line				Conformity Range		Possible Range		
ID		Default		Min	Max	Min	Max	
.027	U LL>> off	U _{THR} OFF	%Unom	115	110	130	100	135
.028	U LL>> on	U _{THR} ON	%Unom	114	100	120	100	135
.029	T U LL>>	Time OFF	ms	0	0	0	0	10000
Comment:		U LL>> off has a fixed offset of 0.25% U _{NOM} subtracted from the displayed value						
Only active for:		Connection Modes: 3-wire, 4-wire (LN+LL)						

Undervoltage2 Line to Line				Conformity Range		Possible Range		
ID		Default		Min	Max	Min	Max	
.031	U LL<< off	U _{THR} OFF	%Unom	15	15	50	0	100
.032	U LL<< on	U _{THR} ON	%Unom	90	50	100	0	100
.033	T U LL<<	Time OFF	ms	250	0	5000	0	10000
Comment:		U LL<< off has a fixed offset of 0.25% U _{NOM} added to the displayed value						
Only active for:		Connection Modes: 3-wire, 4-wire (LN+LL)						

Undervoltage Line to Neutral Activation of a narrower frequency window				Conformity Range		Possible Range		
ID				Default	Min	Max	Min	Max
.123	Uanf w <	Enable Function		off	on/off		on/off	
.124	Uanf w < on	U _{THR} OFF	%Unom	85	85	85	1	100
.125	Uanf w < off	U _{THR} ON	%Unom	90	86	100	2	100
.126	T Uanf w <	Time OFF	ms	0	0	240000	0	240000
Only active for:		Connection Modes: 4-wire (LN+LL)						

Overfrequency1				Conformity Range		Possible Range		
ID				Default	Min	Max	Min	Max
.055	f > off	f _{THR} OFF	Hz	51.50	51.50	51.50	50.00	55.00
.056	f > on	f _{THR} ON	Hz	50.10	50.00	52.00	50.00	55.00
.057	T f >	Time OFF	ms	0	0	0	0	10000
Comment:		f > off has a fixed offset of 0.01 Hz subtracted to the displayed value						
Only active for:		Voltage > 20% U _{NOM}						

Underfrequency1				Conformity Range		Possible Range		
ID				Default	Min	Max	Min	Max
.059	f < off	f _{THR} OFF	Hz	47.50	47.50	47.50	40.00	50.00
.060	f < on	f _{THR} ON	Hz	49.90	47.00	50.00	40.00	50.00
.061	T f <	Time OFF	ms	0	0	0	0	10000
Comment:		f < off has a fixed offset of 0.01 Hz added to the displayed value						
Only active for:		Voltage > 20% U _{NOM}						

Overfrequency nw (narrower window)				Conformity Range		Possible Range		
ID				Default	Min	Max	Min	Max
.062	f nw >	Enable Function		on	on		on/off	
.063	f nw > off	f _{THR} OFF	Hz	50.30	50.30	50.30	50.00	55.00
.064	f nw > on	f _{THR} ON	Hz	50.10	50.00	52.00	50.00	55.00
.065	T f nw >	Time OFF	ms	500	500	500	0	10000
Comment:		f nw > off has a fixed offset of 0.01 Hz subtracted to the displayed value						
Only active for:		Dig Input5=HIGH (local setting)						

Underfrequency nw (narrower window)				Conformity Range		Possible Range		
ID				Default	Min	Max	Min	Max
.066	f nw <	Enable Function		on	on		on/off	
.067	f nw < off	f _{THR} OFF	Hz	49.70	49.70	49.70	45.00	50.00
.068	f nw < on	f _{THR} ON	Hz	49.90	47.00	50.00	45.00	50.00
.069	T f nw <	Time OFF	ms	500	500	500	0	10000
Comment:		f nw < off has a fixed offset of 0.01 Hz added to the displayed value						
Only active for:		Dig Input5=HIGH (local setting)						

Frequency measuring in general				Conformity Range		Possible Range		
ID				Default	Min	Max	Min	Max
.113	F wnd	Window length	ms	Fixed window length 100ms				

Rate of Change of Frequency (RoCoF)				Conformity Range		Possible Range		
ID				Default	Min	Max	Min	Max
.090	RoCoF	Enable Function		on	on / off		on / off	
.091	RoCoF off	RoCoF _{THR} OFF	mHz/s	1000	1000	2000	100	5000
.092	RoCoF on	RoCoF _{THR} ON	mHz/s	800	100	2000	100	5000
.093	RoCoF t	Time OFF	ms	0	0	0	0	5000
.111	RoCoF wnd	Window length	ms	Fixed window length 100ms				

Phase Shift (PShift)				Conformity Range		Possible Range		
ID				Default	Min	Max	Min	Max
.094	PShift	Enable Function		off	on / off		on / off	
.095	PShift off	PShift _{THR} OFF	°	7	7	7	3	15
.096	PShift on	PShift _{THR} ON	°	5	3	7	3	15
		Time OFF	ms	Fixed to the fastest possible disconnection				
.112	PShift wnd	Window length	ms	Fixed window length 100ms				
Comment:		PShift off has a fixed offset of 1° subtracted from the displayed value						

Auxiliary Contact type				Conformity Range		Possible Range		
ID			Default	Min	Max	Min	Max	
.099	Contact	Type	dis. (disabled)	n.o. (normally opened) n.c. (normally closed) dis. (disabled)		n.o. (normally opened) n.c. (normally closed) dis. (disabled)		
.100	Contact t	Time OFF	ms	300	100	300	10	5000
.114	I3 STOP	Type	n.o. (normally opened)	n.o. (normally opened) n.c. (normally closed) dis. (disabled)		n.o. (normally opened) n.c. (normally closed) dis. (disabled)		

Turn-on delay				Conformity Range		Possible Range		
ID				Default	Min	Max	Min	Max
.102	T on delay	Turn on time	s	60	60	60	0	600

Password					Min	Max
ID				Default	Min	Max
.106	PW1	1 st digit of Password		0	0	9
.107	PW2	2 nd digit of Password		0	0	9
.108	PW3	3 rd digit of Password		0	0	9
.109	PW4	4 th digit of Password		0	0	9
Remark:		If all 4 digits of the Password are 0 (default setting) the Password request is skipped				

Device Information		
ID		
.105	ID: xxxxxx	xxxxx = Device ID
	SW: aa.dd.ccb	dd: Software version of Display Software aa: Software version of Measuring Software cc: Index of Configuration set b: Version of Configuration set

10.28 C10-11:2019 HV-ASS [ID 652] Automatic Separation System / High Voltage

Connection Mode			Conformity Range		Possible Range	
ID		Default				
.003	Connection	3-wire	3-wire		2-wire, 3-wire, 4-wire (LN), 4-wire (LN+LL)	

Nominal Voltage				Conformity Range		Possible Range	
ID		Default		Min	Max	Min	Max
.005	ULN/LL nom	Unom Y	V	230.0	57.5	230.0	28.8
		Unom Δ	V	400.0	100.0	400.0	50.0

Functional Safety			Conformity Range		Possible Range	
ID		Default				
.007	Errtol	Fixed to 1ch				
Remark:		1ch means: 1 channel without functional safety and 1 auxilliary contact1 necessary				

Overvoltage1 Line to Line				Conformity Range		Possible Range	
ID		Default		Min	Max	Min	Max
.011	U LL > off	U _{THR} OFF	%Unom	115	100	120	100
.012	U LL > on	U _{THR} ON	%Unom	109	100	120	100
.013	T U LL >	Time OFF	ms	100	100	100000	100
Comment:		U LL > off has a fixed offset of 0.25% U _{NOM} subtracted from the displayed value					
Only active for:		Connection Modes: 3-wire, 4-wire (LN+LL)					

Undervoltage1 Line to Line				Conformity Range		Possible Range	
ID		Default		Min	Max	Min	Max
.015	U LL < off	U _{THR} OFF	%Unom	80	20	100	0
.016	U LL < on	U _{THR} ON	%Unom	90	50	100	0
.017	T U LL <	Time OFF	ms	100	100	100000	100
Comment:		U LL < off has a fixed offset of 0.25% U _{NOM} added to the displayed value					
Only active for:		Connection Modes: 3-wire, 4-wire (LN+LL)					

10 minutes average overvoltage				Conformity Range		Possible Range	
ID		Default		Min	Max	Min	Max
.042	Uavg	Enable function		on		on /off	
.043	Uavg off	U _{THR} OFF	%Unom	110	100	115	100
		U _{THR} ON	%Unom	Fixed Hysteresis (1% U _{NOM})			
		Time OFF	ms	Fixed to fastest possible disconnection			

Overfrequency1				Conformity Range		Possible Range	
ID		Default		Min	Max	Min	Max
.055	f > off	f _{THR} OFF	Hz	51.50	50.00	52.00	50.00
.056	f > on	f _{THR} ON	Hz	50.10	50.00	52.00	50.00
.057	T f >	Time OFF	ms	100	100	100000	100
Comment:		f > off has a fixed offset of 0.01 Hz subtracted to the displayed value					
Only active for:		Voltage > 20% U _{NOM}					

Underfrequency1				Conformity Range		Possible Range	
ID		Default		Min	Max	Min	Max
.059	f < off	f _{THR} OFF	Hz	47.50	47.00	50.00	40.00
.060	f < on	f _{THR} ON	Hz	49.90	47.00	50.00	40.00
.061	T f <	Time OFF	ms	100	100	100000	100
Comment:		f < off has a fixed offset of 0.01 Hz added to the displayed value					
Only active for:		Voltage > 20% U _{NOM}					

Frequency measuring in general				Conformity Range		Possible Range		
ID				Default	Min	Max	Min	Max
.113	F wnd	Window length	ms	Fixed window length 100ms				

Rate of Change of Frequency (RoCoF)				Conformity Range		Possible Range		
ID				Default	Min	Max	Min	Max
.090	RoCoF	Enable Function		off	on / off		on / off	
.091	RoCoF off	RoCoF _{THR} OFF	mHz/s	1000	1000	1000	100	2000
.092	RoCoF on	RoCoF _{THR} ON	mHz/s	800	100	1000	100	1000
.093	RoCoF t	Time OFF	ms	0	0	0	0	1000
.111	RoCoF wnd	Window length	ms	Fixed window length 100ms				

Phase Shift (PShift)				Conformity Range		Possible Range		
ID				Default	Min	Max	Min	Max
.094	PShift	Enable Function		on	on / off		on / off	
.095	PShift off	PShift _{THR} OFF	°	7	7	7	3	15
.096	PShift on	PShift _{THR} ON	°	5	3	7	3	15
		Time OFF	ms	Fixed to the fastest possible disconnection				
.112	PShift wnd	Window length	ms	Fixed window length 100ms				
Comment:		PShift off has a fixed offset of 1° subtracted from the displayed value						

Auxiliary Contact type				Conformity Range		Possible Range		
ID				Default	Min	Max	Min	Max
.099	Contact	Type		dis. (disabled)	n.o. (normally opened) n.c. (normally closed) dis. (disabled)		n.o. (normally opened) n.c. (normally closed) dis. (disabled)	
.100	Contact t	Time OFF	ms	300	100	300	10	5000
.114	I3 STOP	Type		n.o. (normally opened)	n.o. (normally opened) n.c. (normally closed) dis. (disabled)		n.o. (normally opened) n.c. (normally closed) dis. (disabled)	

Turn-on delay				Conformity Range		Possible Range		
ID				Default	Min	Max	Min	Max
.102	Ton delay	Turn on time	s	60	60	60	0	600

Password				Default	Min	Max
ID						
.106	PW1	1 st digit of Password		0	0	9
.107	PW2	2 nd digit of Password		0	0	9
.108	PW3	3 rd digit of Password		0	0	9
.109	PW4	4 th digit of Password		0	0	9
Remark:		If all 4 digits of the Password are 0 (default setting) the Password request is skipped				

Device Information		
ID		
.105	ID: xxxxxx SW: aa.dd.ccb	xxxxx = Device ID dd: Software version of Display Software aa: Software version of Measuring Software cc: Index of Configuration set b: Version of Configuration set

10.29 NA/EEA- CH 2014 [ID 1200] Low Voltage Type A up to 1MW

Connection Mode			Conformity Range		Possible Range	
ID		Default				
.003	Connection	4-wire (LN+LL)	2-wire, 3-wire, 4-wire (LN), 4-wire (LN+LL)		2-wire, 3-wire, 4-wire (LN), 4-wire (LN+LL)	

Nominal Voltage				Conformity Range		Possible Range	
ID		Default		Min	Max	Min	Max
.005	ULN/LL nom	Unom Y	V	230.0	230.0	28.8	241.4
		Unom Δ	V	400.0	400.0	50.0	420.0

Functional Safety			Conformity Range		Possible Range	
ID		Default				
.007	Errtol	Fixed to 2ch				
Remark:		2ch means: 2 channel with functional safety and 2 auxilliary contacts necessary				

Overvoltage1 Line to Line				Conformity Range		Possible Range	
ID		Default		Min	Max	Min	Max
.010	ULL >	Enable function		off		on / off	
.011	ULL > off	U _{THR} OFF	%Unom	110	115	100	135
.012	ULL > on	U _{THR} ON	%Unom	110	110	100	135
.013	T ULL >	Time OFF	ms	60000	180000	50	180000
Only active for:		Connection Modes: 3-wire, 4-wire (LN+LL)					
Comment:		ULL > on has a fixed offset of 0.5% U _{NOM} subtracted from the displayed value					

Undervoltage1 Line to Line				Conformity Range		Possible Range	
ID		Default		Min	Max	Min	Max
.015	ULL < off	U _{THR} OFF	%Unom	80	100	10	100
.016	ULL < on	U _{THR} ON	%Unom	90	100	10	100
.017	T ULL <	Time OFF	ms	100	180000	50	180000
Only active for:		Connection Modes: 3-wire, 4-wire (LN+LL)					
Comment:		ULL < on has a fixed offset of 0.5% U _{NOM} added to the displayed value					

Overvoltage1 Line to Neutral				Conformity Range		Possible Range	
ID		Default		Min	Max	Min	Max
.018	ULN >	Enable function		off		on / off	
.019	ULN > off	U _{THR} OFF	%Unom	110	115	100	135
.020	ULN > on	U _{THR} ON	%Unom	110	110	100	135
.021	T ULN >	Time OFF	ms	60000	180000	50	180000
Only active for:		Connection Modes: 2-wire, 4-wire (LN), 4-wire (LN+LL)					
Comment:		ULN > on has a fixed offset of 0.5% U _{NOM} subtracted from the displayed value					

Undervoltage1 Line to Neutral				Conformity Range		Possible Range	
ID		Default		Min	Max	Min	Max
.023	ULN < off	U _{THR} OFF	%Unom	80	100	10	100
.024	ULN < on	U _{THR} ON	%Unom	90	100	10	100
.025	T ULN <	Time OFF	ms	100	180000	50	180000
Only active for:		Connection Modes: 2-wire, 4-wire (LN), 4-wire (LN+LL)					
Comment:		ULN < on has a fixed offset of 0.5% U _{NOM} added to the displayed value					

Overvoltage2 Line to Line				Conformity Range		Possible Range		
ID				Default	Min	Max	Min	Max
.027	ULL >> off	U _{THR} OFF	%Unom	115	100	125	100	135
.028	ULL >> on	U _{THR} ON	%Unom	110	100	110	100	135
.029	T ULL >>	Time OFF	ms	100	50	180000	50	180000
Only active for:		Connection Modes: 3-wire, 4-wire (LN+LL)						
Comment:		ULL >> on has a fixed offset of 0.5% U _{NOM} subtracted from the displayed value						

Overvoltage2 Line to Neutral				Conformity Range		Possible Range		
ID				Default	Min	Max	Min	Max
.035	ULN >> off	U _{THR} OFF	%Unom	115	100	125	100	135
.036	ULN >> on	U _{THR} ON	%Unom	110	100	110	100	135
.037	T ULN >>	Time OFF	ms	100	50	180000	50	180000
Only active for:		Connection Modes: 2-wire, 4-wire (LN), 4-wire (LN+LL)						
Comment:		ULN >> on has a fixed offset of 0.5% U _{NOM} subtracted from the displayed value						

10 minutes average overvoltage				Conformity Range		Possible Range		
ID				Default	Min	Max	Min	Max
.042	U10min	Enable function		on	on/off		on /off	
.043	U10min off	U _{THR} OFF	%Unom	110	110	115	100	135
		U _{THR} ON	%Unom	Fixed Hysteresis (0.9% U _{NOM})				
		Time OFF	ms	Fixed to fastest possible disconnection				

Overfrequency1				Conformity Range		Possible Range		
ID				Default	Min	Max	Min	Max
.055	f > off	f _{THR} OFF	Hz	51.50	50.00	53.00	50.00	55.00
.056	f > on	f _{THR} ON	Hz	50.05	50.00	50.05	50.00	55.00
.057	T f >	Time OFF	ms	50	50	50	50	180000
Comment:		f > on has a fixed offset of 0.01 Hz subtracted to the displayed value						

Underfrequency1				Conformity Range		Possible Range		
ID				Default	Min	Max	Min	Max
.059	f < off	f _{THR} OFF	Hz	47.50	47.00	50.00	45.00	50.00
.060	f < on	f _{THR} ON	Hz	47.50	47.50	50.00	45.00	50.00
.061	T f <	Time OFF	ms	50	50	50	50	180000
Comment:		f < on has a fixed offset of 0.01 Hz added to the displayed value						

Frequency measuring in general				Conformity Range		Possible Range		
ID				Default	Min	Max	Min	Max
.113	F wnd	Window length	ms	Fixed window length 100ms				

Auxiliary Contact type				Conformity Range		Possible Range		
ID				Default	Min	Max	Min	Max
.099	Contact	Type	n.c. (normally closed)		n.o. (normally opened) n.c. (normally closed)		n.o. (normally opened) n.c. (normally closed) dis. (disabled)	
.100	T Contact	Time OFF	ms	Fixed to 500ms				
.114	I3 STOP	Type	n.o. (normally opened)		n.o. (normally opened) n.c. (normally closed) dis. (disabled)		n.o. (normally opened) n.c. (normally closed) dis. (disabled)	

Turn-on delay				Conformity Range		Possible Range		
ID				Default	Min	Max	Min	Max
.102	Ton delay	Turn on time	s	120	0	1800	0	1800

Password					
ID			Default	Min	Max
.106	PW1	1 st digit of Password	0	0	9
.107	PW2	2 nd digit of Password	0	0	9
.108	PW3	3 rd digit of Password	0	0	9
.109	PW4	4 th digit of Password	0	0	9
Remark:		If all 4 digits of the Password are 0 (default setting) the Password request is skipped			

Device Information		
ID		
.105	ID: xxxxxx SW: aa.dd.ccb	xxxxx = Device ID dd: Software version of Display Software aa: Software version of Measuring Software cc: Index of Configuration set b: Version of Configuration set

10.30 NA/EEA-NE7 - CH 2020 [ID 1220] Low Voltage Type A > 800W to ≤ 250kW

Connection Mode			Conformity Range		Possible Range	
ID		Default				
.003	Connection	4-wire (LN+LL)	4-wire (LN+LL)		2-wire, 3-wire, 4-wire (LN), 4-wire (LN+LL)	

Nominal Voltage				Conformity Range		Possible Range	
ID		Default		Min	Max	Min	Max
.005	ULN/LL nom	Unom Y	V	230.0	230.0	28.8	241.4
		Unom Δ	V	400.0	400.0	50.0	420.0

Functional Safety			Conformity Range		Possible Range	
ID		Default				
.007	Errtol	Fixed to 2ch				
Remark:		2ch means: 2 channel with functional safety and 2 auxilliary contacts necessary				

Overvoltage1 Line to Line				Conformity Range		Possible Range	
ID		Default		Min	Max	Min	Max
.010	ULL >	Enable function		off		on / off	
.011	ULL > off	U _{THR} OFF	%Unom	110	115	100	135
.012	ULL > on	U _{THR} ON	%Unom	110	110	100	135
.013	T ULL >	Time OFF	ms	60000	180000	50	180000
Only active for:		Connection Modes: 3-wire, 4-wire (LN+LL)					
Comment:		ULL > on has a fixed offset of 0.5% U _{NOM} subtracted from the displayed value					

Undervoltage1 Line to Line				Conformity Range		Possible Range	
ID		Default		Min	Max	Min	Max
.015	ULL < off	U _{THR} OFF	%Unom	80	100	10	100
.016	ULL < on	U _{THR} ON	%Unom	85	100	10	100
.017	T ULL <	Time OFF	ms	1500	10000	50	180000
Only active for:		Connection Modes: 3-wire, 4-wire (LN+LL)					
Comment:		ULL > on has a fixed offset of 0.5% U _{NOM} added to the displayed value					

Overvoltage1 Line to Neutral				Conformity Range		Possible Range	
ID		Default		Min	Max	Min	Max
.018	ULN >	Enable function		off		on / off	
.019	ULN > off	U _{THR} OFF	%Unom	110	115	100	135
.020	ULN > on	U _{THR} ON	%Unom	110	110	100	135
.021	T ULN >	Time OFF	ms	60000	180000	50	180000
Only active for:		Connection Modes: 2-wire, 4-wire (LN), 4-wire (LN+LL)					
Comment:		ULN > on has a fixed offset of 0.5% U _{NOM} subtracted from the displayed value					

Undervoltage1 Line to Neutral				Conformity Range		Possible Range	
ID		Default		Min	Max	Min	Max
.023	ULN < off	U _{THR} OFF	%Unom	80	100	10	100
.024	ULN < on	U _{THR} ON	%Unom	85	100	10	100
.025	T ULN <	Time OFF	ms	1500	10000	50	180000
Only active for:		Connection Modes: 2-wire, 4-wire (LN), 4-wire (LN+LL)					
Comment:		ULN > on has a fixed offset of 0.5% U _{NOM} added to the displayed value					

Overvoltage2 Line to Line				Conformity Range		Possible Range		
ID				Default	Min	Max	Min	Max
.027	ULL >> off	U _{THR} OFF	%Unom	120	100	125	100	135
.028	ULL >> on	U _{THR} ON	%Unom	110	100	110	100	135
.029	T ULL >>	Time OFF	ms	100	50	1000	50	180000
Only active for:		Connection Modes: 3-wire, 4-wire (LN+LL)						
Comment:		ULL >> on has a fixed offset of 0.5% U _{NOM} subtracted from the displayed value						

Undervoltage2 Line to Line				Conformity Range		Possible Range		
ID				Default	Min	Max	Min	Max
.031	ULL << off	U _{THR} OFF	%Unom	45	10	100	10	100
.032	ULL << on	U _{THR} ON	%Unom	85	85	100	10	100
.033	T ULL <<	Time OFF	ms	300	50	1000	50	180000
Only active for:		Connection Modes: 3-wire, 4-wire (LN+LL)						
Comment:		ULL << on has a fixed offset of 0.5% U _{NOM} added to the displayed value						

Overvoltage2 Line to Neutral				Conformity Range		Possible Range		
ID				Default	Min	Max	Min	Max
.035	ULN >> off	U _{THR} OFF	%Unom	120	100	125	100	135
.036	ULN >> on	U _{THR} ON	%Unom	110	100	110	100	135
.037	T ULN >>	Time OFF	ms	100	50	1000	50	180000
Only active for:		Connection Modes: 2-wire, 4-wire (LN), 4-wire (LN+LL)						
Comment:		ULN >> on has a fixed offset of 0.5% U _{NOM} subtracted from the displayed value						

Undervoltage2 Line to Neutral				Conformity Range		Possible Range		
ID				Default	Min	Max	Min	Max
.039	ULN << off	U _{THR} OFF	%Unom	45	10	100	10	100
.040	ULN << on	U _{THR} ON	%Unom	85	85	100	10	100
.041	T ULN <<	Time OFF	ms	300	50	1000	50	180000
Only active for:		Connection Modes: 2-wire, 4-wire (LN), 4-wire (LN+LL)						
Comment:		ULN << on has a fixed offset of 0.5% U _{NOM} added to the displayed value						

10 minutes average overvoltage				Conformity Range		Possible Range		
ID				Default	Min	Max	Min	Max
.042	U10min	Enable function		On	on/off		on /off	
.043	U10min off	U _{THR} OFF	%Unom	110	110	115	100	135
		U _{THR} ON	%Unom	Fixed Hysteresis (0.9% U _{NOM})				
		Time OFF	ms	Fixed to fastest possible disconnection				

Overfrequency1				Conformity Range		Possible Range		
ID				Default	Min	Max	Min	Max
.055	f > off	f _{THR} OFF	Hz	51.50	50.00	53.00	50.00	55.00
.056	f > on	f _{THR} ON	Hz	50.1	50.00	50.1	50.00	55.00
.057	T f >	Time OFF	ms	50	50	50	50	180000
Comment:		f < on has a fixed offset of 0.01 Hz added to the displayed value						

Underfrequency1				Conformity Range		Possible Range		
ID				Default	Min	Max	Min	Max
.059	f < off	f _{THR} OFF	Hz	47.50	47.00	50.00	45.00	50.00
.060	f < on	f _{THR} ON	Hz	47.50	47.50	50.00	45.00	50.00
.061	T f <	Time OFF	ms	50	50	50	50	180000
Comment:		f < on has a fixed offset of 0.01 Hz added to the displayed value						

Rate of Change of Frequency (RoCoF)				Conformity Range		Possible Range		
ID				Default	Min	Max	Min	Max
.090	RoCoF	Enable Function		off	on / off		on / off	
.091	RoCoF off	RoCoF _{THR} OFF	mHz/s	2000	2000	2000	100	5000
.092	RoCoF on	RoCoF _{THR} ON	mHz/s	1900	100	1900	100	5000
.093	RoCoF t	Time OFF	ms	0	0	500	0	10000
.111	RoCoF wnd	Window length	ms	Fixed window length 500ms				

Frequency measuring in general				Conformity Range		Possible Range		
ID				Default	Min	Max	Min	Max
.113	F wnd	Window length	ms	Fixed window length 100ms				

Auxiliary Contact type				Conformity Range		Possible Range		
ID			Default		Min	Max	Min	Max
.099	Contact	Type	n.c. (normally closed)		n.o. (normally opened) n.c. (normally closed)		n.o. (normally opened) n.c. (normally closed) dis. (disabled)	
.100	T Contact	Time OFF	ms	Fixed to 500ms				
.114	I3 STOP	Type	n.o. (normally opened)		n.o. (normally opened) n.c. (normally closed) dis. (disabled)		n.o. (normally opened) n.c. (normally closed) dis. (disabled)	

Turn-on delay				Conformity Range		Possible Range		
ID				Default	Min	Max	Min	Max
.102	Ton delay	Turn on time	s	60	60	1800	0	1800

Password						
ID				Default	Min	Max
.106	PW1	1 st digit of Password		0	0	9
.107	PW2	2 nd digit of Password		0	0	9
.108	PW3	3 rd digit of Password		0	0	9
.109	PW4	4 th digit of Password		0	0	9
Remark:		If all 4 digits of the Password are 0 (default setting) the Password request is skipped				

Device Information		
ID		
.105	ID: xxxxxx	xxxxx = Device ID
	SW: aa.dd.ccb	dd: Software version of Display Software aa: Software version of Measuring Software cc: Index of Configuration set b: Version of Configuration set

10.31 NA/EEA-NE7 - CH 2020 [ID 1221] Low Voltage Type B > 250kW to ≤ 36MW

Connection Mode			Conformity Range	Possible Range
ID		Default		
.003	Connection	4-wire (LN+LL)	4-wire (LN+LL)	2-wire, 3-wire, 4-wire (LN), 4-wire (LN+LL)

Nominal Voltage				Conformity Range		Possible Range	
ID		Default		Min	Max	Min	Max
.005	ULN/LL nom	Unom Y	V	230.0	230.0	28.8	241.4
		Unom Δ	V	400.0	400.0	50.0	420.0

Functional Safety			Conformity Range	Possible Range
ID		Default		
.007	Errtol	Fixed to 2ch		
Remark:		2ch means: 2 channel with functional safety and 2 auxilliary contacts necessary		

Overvoltage1 Line to Line				Conformity Range		Possible Range	
ID		Default		Min	Max	Min	Max
.010	ULL >	Enable function		off		on / off	
.011	ULL > off	U _{THR} OFF	%Unom	110	100	115	100
.012	ULL > on	U _{THR} ON	%Unom	110	100	110	135
.013	T ULL >	Time OFF	ms	60000	50	180000	50
Only active for:		Connection Modes: 3-wire, 4-wire (LN+LL)					
Comment:		ULL > on has a fixed offset of 0.5% U _{NOM} subtracted from the displayed value					

Undervoltage1 Line to Line				Conformity Range		Possible Range	
ID		Default		Min	Max	Min	Max
.015	ULL < off	U _{THR} OFF	%Unom	80	10	100	10
.016	ULL < on	U _{THR} ON	%Unom	85	85	100	100
.017	T ULL <	Time OFF	ms	1000	50	10000	50
Only active for:		Connection Modes: 3-wire, 4-wire (LN+LL)					
Comment:		ULL > on has a fixed offset of 0.5% U _{NOM} added to the displayed value					

Overvoltage1 Line to Neutral				Conformity Range		Possible Range	
ID		Default		Min	Max	Min	Max
.018	ULN >	Enable function		off		on / off	
.019	ULN > off	U _{THR} OFF	%Unom	110	100	115	100
.020	ULN > on	U _{THR} ON	%Unom	110	100	110	135
.021	T ULN >	Time OFF	ms	60000	50	180000	50
Only active for:		Connection Modes: 2-wire, 4-wire (LN), 4-wire (LN+LL)					
Comment:		ULN > on has a fixed offset of 0.5% U _{NOM} subtracted from the displayed value					

Undervoltage1 Line to Neutral				Conformity Range		Possible Range	
ID		Default		Min	Max	Min	Max
.023	ULN < off	U _{THR} OFF	%Unom	80	10	100	10
.024	ULN < on	U _{THR} ON	%Unom	85	85	100	100
.025	T ULN <	Time OFF	ms	1000	50	10000	50
Only active for:		Connection Modes: 2-wire, 4-wire (LN), 4-wire (LN+LL)					
Comment:		ULN > on has a fixed offset of 0.5% U _{NOM} added to the displayed value					

Overvoltage2 Line to Line				Conformity Range		Possible Range		
ID				Default	Min	Max	Min	Max
.027	ULL >> off	U _{THR} OFF	%Unom	120	100	125	100	135
.028	ULL >> on	U _{THR} ON	%Unom	11010	100	110	100	135
.029	T ULL >>	Time OFF	ms	100	50	1000	50	180000
Only active for:		Connection Modes: 3-wire, 4-wire (LN+LL)						
Comment:		ULL >> on has a fixed offset of 0.5% U _{NOM} subtracted from the displayed value						

Undervoltage2 Line to Line				Conformity Range		Possible Range		
ID				Default	Min	Max	Min	Max
.031	ULL << off	U _{THR} OFF	%Unom	45	10	100	10	100
.032	ULL << on	U _{THR} ON	%Unom	85	85	100	10	100
.033	T ULL <<	Time OFF	ms	300	50	1000	50	180000
Only active for:		Connection Modes: 3-wire, 4-wire (LN+LL)						
Comment:		ULL << on has a fixed offset of 0.5% U _{NOM} added to the displayed value						

Overvoltage2 Line to Neutral				Conformity Range		Possible Range		
ID				Default	Min	Max	Min	Max
.035	ULN >> off	U _{THR} OFF	%Unom	120	100	125	100	135
.036	ULN >> on	U _{THR} ON	%Unom	11010	100	110	100	135
.037	T ULN >>	Time OFF	ms	100	50	1000	50	180000
Only active for:		Connection Modes: 2-wire, 4-wire (LN), 4-wire (LN+LL)						
Comment:		ULN >> on has a fixed offset of 0.5% U _{NOM} subtracted from the displayed value						

Undervoltage2 Line to Neutral				Conformity Range		Possible Range		
ID				Default	Min	Max	Min	Max
.039	ULN << off	U _{THR} OFF	%Unom	45	10	100	10	100
.040	ULN << on	U _{THR} ON	%Unom	85	85	100	10	100
.041	T ULN <<	Time OFF	ms	300	50	1000	50	180000
Only active for:		Connection Modes: 2-wire, 4-wire (LN), 4-wire (LN+LL)						
Comment:		ULN << on has a fixed offset of 0.5% U _{NOM} added to the displayed value						

10 minutes average overvoltage				Conformity Range		Possible Range		
ID				Default	Min	Max	Min	Max
.042	U10min	Enable function		On	on/off		on /off	
.043	U10min off	U _{THR} OFF	%Unom	110	110	115	100	135
		U _{THR} ON	%Unom	Fixed Hysteresis (0.9% U _{NOM})				
		Time OFF	ms	Fixed to fastest possible disconnection				

Overfrequency1				Conformity Range		Possible Range		
ID				Default	Min	Max	Min	Max
.055	f > off	f _{THR} OFF	Hz	51.50	50.00	53.00	50.00	55.00
.056	f > on	f _{THR} ON	Hz	50.1	50.00	50.1	50.00	55.00
.057	T f >	Time OFF	ms	50	50	50	50	180000
Comment:		f < on has a fixed offset of 0.01 Hz added to the displayed value						

Underfrequency1				Conformity Range		Possible Range		
ID				Default	Min	Max	Min	Max
.059	f < off	f _{THR} OFF	Hz	47.50	47.00	50.00	45.00	50.00
.060	f < on	f _{THR} ON	Hz	47.50	47.50	50.00	45.00	50.00
.061	T f <	Time OFF	ms	50	50	50	50	180000
Comment:		f < on has a fixed offset of 0.01 Hz added to the displayed value						

Rate of Change of Frequency (RoCoF)				Conformity Range		Possible Range		
ID				Default	Min	Max	Min	Max
.090	RoCoF	Enable Function		off	on / off		on / off	
.091	RoCoF off	RoCoF _{THR} OFF	mHz/s	2000	2000	2000	100	5000
.092	RoCoF on	RoCoF _{THR} ON	mHz/s	1900	100	1900	100	5000
.093	RoCoF t	Time OFF	ms	0	0	500	0	10000
.111	RoCoF wnd	Window length	ms	Fixed window length 500ms				

Frequency measuring in general				Conformity Range		Possible Range		
ID				Default	Min	Max	Min	Max
.113	F wnd	Window length	ms	Fixed window length 100ms				

Auxiliary Contact type				Conformity Range		Possible Range		
ID			Default		Min	Max	Min	Max
.099	Contact	Type	n.c. (normally closed)		n.o. (normally opened) n.c. (normally closed)		n.o. (normally opened) n.c. (normally closed) dis. (disabled)	
.100	T Contact	Time OFF	ms	Fixed to 500ms				
.114	I3 STOP	Type	n.o. (normally opened)		n.o. (normally opened) n.c. (normally closed) dis. (disabled)		n.o. (normally opened) n.c. (normally closed) dis. (disabled)	

Turn-on delay				Conformity Range		Possible Range		
ID				Default	Min	Max	Min	Max
.102	Ton delay	Turn on time	s	600	60	1800	0	1800

Password						
ID				Default	Min	Max
.106	PW1	1 st digit of Password		0	0	9
.107	PW2	2 nd digit of Password		0	0	9
.108	PW3	3 rd digit of Password		0	0	9
.109	PW4	4 th digit of Password		0	0	9
Remark:		If all 4 digits of the Password are 0 (default setting) the Password request is skipped				

Device Information		
ID		
.105	ID: xxxxxx	xxxxx = Device ID
	SW: aa.dd.ccb	dd: Software version of Display Software aa: Software version of Measuring Software cc: Index of Configuration set b: Version of Configuration set

10.32 EN50549-1:2019 LV Netherlands [ID 901]

Connection Mode			Conformity Range		Possible Range	
ID		Default				
.003	Connection	4-wire (LN+LL)	2-wire, 3-wire, 4-wire (LN), 4-wire (LN+LL)		2-wire, 3-wire, 4-wire (LN), 4-wire (LN+LL)	

Nominal Voltage				Conformity Range		Possible Range	
ID		Default		Min	Max	Min	Max
.005	ULN/LL nom	Unom Y	V	230.0	230.0	230.0	100.0
		Unom Δ	V	400.0	400.0	400.0	50.0

Functional Safety			Conformity Range		Possible Range	
ID		Default				
.007	Errtol	Fixed to 2ch				

Overvoltage1 Line to Line				Conformity Range		Possible Range	
ID		Default		Min	Max	Min	Max
.010	ULL >	Enable Function		on/off		on/off	
.011	ULL > off	U _{THR} OFF	%Unom	110	120	100	135
.012	ULL > on	U _{THR} ON	%Unom	109	120	100	135
.013	T ULL >	Time OFF	ms	200	100000	100	300000
Comment:		ULL > on has a fixed offset of 0.5% U _{NOM} subtracted from the displayed value					
Only active for:		Connection Modes: 3-wire, 4-wire (LN+LL)					

Undervoltage1 Line to Line				Conformity Range		Possible Range	
ID		Default		Min	Max	Min	Max
.014	ULL <	Enable Function		on/off		on/off	
.015	ULL < off	U _{THR} OFF	%Unom	80	100	10	100
.016	ULL < on	U _{THR} ON	%Unom	85	100	10	100
.017	T ULL <	Time OFF	ms	3000	100000	100	3000000
Comment:		ULL < on has a fixed offset of 0.5% U _{NOM} added to the displayed value					
Only active for:		Connection Modes: 3-wire, 4-wire (LN+LL)					

Overvoltage1 Line to Neutral				Conformity Range		Possible Range	
ID		Default		Min	Max	Min	Max
.018	ULN >	Enable Function		on/off		on/off	
.019	ULN > off	U _{THR} OFF	%Unom	110	120	100	135
.020	ULN > on	U _{THR} ON	%Unom	109	120	100	135
.021	T ULN >	Time OFF	ms	200	100000	100	300000
Comment:		ULN > on has a fixed offset of 0.5% U _{NOM} subtracted from the displayed value					
Only active for:		Connection Modes: 2-wire, 4-wire (LN), 4-wire (LN+LL)					

Undervoltage1 Line to Neutral				Conformity Range		Possible Range	
ID		Default		Min	Max	Min	Max
.022	ULN <	Enable Function		on/off		on/off	
.023	ULN < off	U _{THR} OFF	%Unom	80	100	10	100
.024	ULN < on	U _{THR} ON	%Unom	85	100	10	100
.025	T LN <	Time OFF	ms	3000	100000	0	300000
Comment:		ULN < off has a fixed offset of 0.5% U _{NOM} added to the displayed value					
Only active for:		Connection Modes: 2-wire, 4-wire (LN), 4-wire (LN+LL)					

Overvoltage2 Line to Line				Conformity Range		Possible Range		
ID				Default	Min	Max	Min	Max
.026	ULL >>	Enable Function		on	on/off		on/off	
.027	ULL >> off	U _{THR} OFF	%Unom	120	100	120	100	135
.028	ULL >> on	U _{THR} ON	%Unom	109	100	120	100	135
.029	T ULL >	Time OFF	ms	100	100	5000	100	300000
Comment:		ULL >> on has a fixed offset of 0.5% U _{NOM} subtracted from the displayed value						
Only active for:		Connection Modes: 3-wire, 4-wire (LN+LL)						

Undervoltage2 Line to Line				Conformity Range		Possible Range		
ID				Default	Min	Max	Min	Max
.030	ULL <<	Enable Function		on	on/off		on/off	
.031	ULL << off	U _{THR} OFF	%Unom	30	20	100	10	100
.032	ULL << on	U _{THR} ON	%Unom	85	50	100	10	100
.033	T ULL <<	Time OFF	ms	100	100	5000	100	300000
Comment:		ULL << on has a fixed offset of 0.5% U _{NOM} added to the displayed value						
Only active for:		Connection Modes: 3-wire, 4-wire (LN+LL)						

Overvoltage2 Line to Neutral				Conformity Range		Possible Range		
ID				Default	Min	Max	Min	Max
.034	ULN>>	Enable Function		on	on/off		on/off	
.035	ULN>> off	U _{THR} OFF	%Unom	120	100	130	100	135
.036	ULN>> on	U _{THR} ON	%Unom	109	100	120	100	135
.037	T ULN>>	Time OFF	ms	100	100	5000	100	300000
		Time OFF	ms	Fixed to fastest possible disconnection				
Comment:		U LN > off has a fixed offset of 0.5% U _{NOM} subtracted from the displayed value						
Only active for:		Connection Modes: 2-wire, 4-wire (LN), 4-wire (LN+LL)						

Undervoltage2 Line to Neutral				Conformity Range		Possible Range		
ID				Default	Min	Max	Min	Max
.038	ULN<<	Enable Function		on	on/off		on/off	
.039	ULN<< off	U _{THR} OFF	%Unom	30	20	100	10	100
.040	ULN<< on	U _{THR} ON	%Unom	85	50	100	10	100
.041	T ULN<<	Time OFF	ms	100	100	5000	100	300000
Comment:		U LN < off has a fixed offset of 0.25% U _{NOM} added to the displayed value						
Only active for:		Connection Modes: 2-wire, 4-wire (LN), 4-wire (LN+LL)						

10 minutes average overvoltage				Conformity Range		Possible Range		
ID				Default	Min	Max	Min	Max
.042	Uavg	Enable function		on	on / off		on / off	
.043	Uavg off	U _{THR} OFF	%Unom	110	100	115	100	135
.044	Uavg on	U _{THR} ON	%Unom	109	100	115	100	135
		Time OFF	ms	Fixed to fastest possible disconnection				

Zero Voltage Line to Neutral				Conformity Range		Possible Range		
ID				Default	Min	Max	Min	Max
.115	Uzero >	Enable Function		off	on/off		on/off	
.116	Uzero> off	U _{THR} OFF	%Unom	20	1	100	1	100
.117	Uzero> on	U _{THR} ON	%Unom	15	1	100	1	100
.118	T Uzero >	Time OFF	ms	1500	200	100000	0	300000
Only active for:		Connection Modes: 4-wire (LN+LL)						

Residual Voltage (3 x Zero Voltage) Line to Neutral Activation of a narrower frequency window				Conformity Range		Possible Range		
ID				Default	Min	Max	Min	Max
.119	Ures-anfw>	Enable Function		off	on/off		on/off	
.120	U res > on	U _{THR} OFF	%Unom	5	2	20	2	200
.121	U res > off	U _{THR} ON	%Unom	3	1	20	1	100
.122	T Ures >	Time OFF	ms	200	0	240000	0	240000
Only active for:		Connection Modes: 4-wire (LN+LL)						

Undervoltage Line to Neutral Activation of a narrower frequency window				Conformity Range		Possible Range		
ID				Default	Min	Max	Min	Max
.123	Uanf <	Enable Function		off	on/off		on/off	
.124	Uanf < on	U _{THR} OFF	%Unom	85	21	100	2	100
.125	Uanf < off	U _{THR} ON	%Unom	86	21	100	2	100
.126	T Uanf <	Time OFF	ms	0	0	240000	0	240000
Only active for:		Connection Modes: 4-wire (LN+LL)						

Overfrequency1				Conformity Range		Possible Range		
ID				Default	Min	Max	Min	Max
.054	f >	Enable Function		on	on		on/off	
.055	f > off	f _{THR} OFF	Hz	51.50	50.00	52.00	50.00	55.00
.056	f > on	f _{THR} ON	Hz	50.10	50.00	52.00	50.00	55.00
.057	T f >	Time OFF	ms	100	100	100000	100	300000
Comment:		f > on has a fixed offset of 0.01 Hz subtracted to the displayed value						
Only active for:		Voltage > 20% U _{NOM}						

Underfrequency1				Conformity Range		Possible Range		
ID				Default	Min	Max	Min	Max
.058	f <	Enable Function		on	on		on/off	
.059	f < off	f _{THR} OFF	Hz	47.50	47.00	50.00	45.00	50.00
.060	f < on	f _{THR} ON	Hz	48.50	47.00	50.00	45.00	50.00
.061	T f <	Time OFF	ms	100	100	100000	100	300000
Comment:		f < on has a fixed offset of 0.01 Hz added to the displayed value						
Only active for:		Voltage > 20% U _{NOM}						

Overfrequency nw (narrower window)				Conformity Range		Possible Range		
ID				Default	Min	Max	Min	Max
.062	f nw >	Enable Function		off	on/off		on/off	
.063	f nw > off	f _{THR} OFF	Hz	50.30	50.00	52.00	50.00	55.00
.064	f nw > on	f _{THR} ON	Hz	50.10	50.00	52.00	50.00	55.00
.065	T f nw >	Time OFF	ms	500	100	5000	100	300000
Comment:		f nw > off has a fixed offset of 0.01 Hz subtracted to the displayed value						
Only active for:		Ures-anfw, Uanf, Dig Input5=HIGH (local setting)						

Underfrequency nw (narrower window)				Conformity Range		Possible Range		
ID				Default	Min	Max	Min	Max
.066	f nw <	Enable Function		off	on/off		on/off	
.067	f nw < off	f _{THR} OFF	Hz	49.70	47.00	50.00	45.00	50.00
.068	f nw < on	f _{THR} ON	Hz	49.80	47.00	50.00	45.00	50.00
.069	T f nw <	Time OFF	ms	500	100	5000	100	300000
Comment:		f nw < off has a fixed offset of 0.01 Hz added to the displayed value						
Only active for:		Ures-anfw, Uanf, Dig Input5=HIGH (local setting)						

Frequency measuring in general				Conformity Range		Possible Range		
ID				Default	Min	Max	Min	Max
.113	F wnd	Window length	ms	Fixed window length 100ms				

Rate of Change of Frequency (RoCoF)				Conformity Range		Possible Range		
ID				Default	Min	Max	Min	Max
.090	ROCOF	Enable Function		off	on / off		on / off	
.091	ROCOF off	RoCoF _{THR} OFF	mHz/s	1000	200	9990	100	9990
.092	ROCOF on	RoCoF _{THR} ON	mHz/s	800	100	9990	100	9990
.093	ROCOF t	Time OFF	ms	0	0	5000	0	5000
.111	RoCoF wnd	Window length	ms	Fixed window length 100ms				

Phase Shift (PShift)				Conformity Range		Possible Range		
ID				Default	Min	Max	Min	Max
.094	PShift	Enable Function		off	on / off		on / off	
.095	PShift off	PShift _{THR} OFF	°	7	2	15	2	15
.096	PShift on	PShift _{THR} ON	°	5	1	15	1	15
		Time OFF	ms	Fixed to the fastest possible disconnection				
.112	PShift wnd	Window length	ms	Fixed window length 100ms				
Comment:		PShift off has a fixed offset of 1° subtracted from the displayed value						

Auxiliary Contact type				Conformity Range		Possible Range		
ID			Default		Min	Max	Min	Max
.099	Contact	Type	dis. (disabled)		n.o. (normally opened) n.c. (normally closed) dis. (disabled)		n.o. (normally opened) n.c. (normally closed) dis. (disabled)	
.100	Contact t	Time OFF	ms	500				
.114	I3 STOP	Type	n.o. (normally opened)		n.o. (normally opened) n.c. (normally closed) dis. (disabled)		n.o. (normally opened) n.c. (normally closed) dis. (disabled)	

Turn-on delay				Conformity Range		Possible Range		
ID				Default	Min	Max	Min	Max
.102	T on delay	Turn on time	s	60	10	600	10	600

Password						
ID				Default	Min	Max
.106	PW1	1 st digit of Password		0	0	9
.107	PW2	2 nd digit of Password		0	0	9
.108	PW3	3 rd digit of Password		0	0	9
.109	PW4	4 th digit of Password		0	0	9
Remark:		If all 4 digits of the Password are 0 (default setting) the Password request is skipped				

Device Information		
ID		
.105	ID: xxxxxx SW: aa.dd.ccb	xxxxx = Device ID dd: Software version of Display Software aa: Software version of Measuring Software cc: Index of Configuration set b: Version of Configuration set

10.33 EN50549-2:2019 HV Netherlands [ID 926]

Connection Mode			Conformity Range		Possible Range	
ID		Default				
.003	Connection	4-wire (LN+LL)	3-wire, 4-wire (LN), 4-wire (LN+LL)		2-wire, 3-wire, 4-wire (LN), 4-wire (LN+LL)	

Nominal Voltage				Conformity Range		Possible Range		
ID		Default		Min	Max	Min	Max	
.005	ULN/LL nom	Unom Y	V	230.0	57.5	230.0	100.0	240.0
		Unom Δ	V	400.0	100.0	400.0	50.0	420.0

Functional Safety			Conformity Range		Possible Range	
ID		Default				
.007	Errtol	Fixed to 2ch				

Overvoltage1 Line to Line				Conformity Range		Possible Range		
ID		Default		Min	Max	Min	Max	
.010	ULL >	Enable Function		on		on/off		
.011	ULL > off	U _{THR} OFF	%Unom	110	100	120	100	135
.012	ULL > on	U _{THR} ON	%Unom	109	100	120	100	135
.013	T ULL >	Time OFF	ms	200	100	100000	100	300000
Comment:		ULL > on has a fixed offset of 0.5% U _{NOM} subtracted from the displayed value						
Only active for:		Connection Modes: 3-wire, 4-wire (LN+LL)						

Undervoltage1 Line to Line				Conformity Range		Possible Range		
ID		Default		Min	Max	Min	Max	
.014	ULL <	Enable Function		on		on/off		
.015	ULL < off	U _{THR} OFF	%Unom	80	20	100	10	100
.016	ULL < on	U _{THR} ON	%Unom	90	50	100	10	100
.017	T ULL <	Time OFF	ms	3000	100	100000	100	3000000
Comment:		ULL < on has a fixed offset of 0.5% U _{NOM} added to the displayed value						
Only active for:		Connection Modes: 3-wire, 4-wire (LN+LL)						

Overvoltage1 Line to Neutral				Conformity Range		Possible Range		
ID		Default		Min	Max	Min	Max	
.018	ULN >	Enable Function		on		on/off		
.019	ULN > off	U _{THR} OFF	%Unom	110	100	120	100	135
.020	ULN > on	U _{THR} ON	%Unom	109	100	120	100	135
.021	T ULN >	Time OFF	ms	200	100	100000	100	300000
Comment:		ULN > on has a fixed offset of 0.5% U _{NOM} subtracted from the displayed value						
Only active for:		Connection Modes: 2-wire, 4-wire (LN), 4-wire (LN+LL)						

Undervoltage1 Line to Neutral				Conformity Range		Possible Range		
ID		Default		Min	Max	Min	Max	
.022	ULN <	Enable Function		on		on/off		
.023	ULN < off	U _{THR} OFF	%Unom	80	20	100	10	100
.024	ULN < on	U _{THR} ON	%Unom	90	50	100	10	100
.025	T LN <	Time OFF	ms	3000	100	100000	0	300000
Comment:		ULN < off has a fixed offset of 0.5% U _{NOM} added to the displayed value						
Only active for:		Connection Modes: 2-wire, 4-wire (LN), 4-wire (LN+LL)						

Overvoltage2 Line to Line				Conformity Range		Possible Range		
ID				Default	Min	Max	Min	Max
.026	ULL >>	Enable Function		on	on/off		on/off	
.027	ULL >> off	U _{THR} OFF	%Unom	120	100	120	100	135
.028	ULL >> on	U _{THR} ON	%Unom	109	100	120	100	135
.029	T ULL >	Time OFF	ms	100	100	5000	100	300000
Comment:		ULL >> on has a fixed offset of 0.5% U _{NOM} subtracted from the displayed value						
Only active for:		Connection Modes: 3-wire, 4-wire (LN+LL)						

Undervoltage2 Line to Line				Conformity Range		Possible Range		
ID				Default	Min	Max	Min	Max
.030	ULL <<	Enable Function		on	on/off		on/off	
.031	ULL << off	U _{THR} OFF	%Unom	30	20	100	10	100
.032	ULL << on	U _{THR} ON	%Unom	90	50	100	10	100
.033	T ULL <<	Time OFF	ms	100	100	5000	100	300000
Comment:		ULL << on has a fixed offset of 0.5% U _{NOM} added to the displayed value						
Only active for:		Connection Modes: 3-wire, 4-wire (LN+LL)						

Overvoltage2 Line to Neutral				Conformity Range		Possible Range		
ID				Default	Min	Max	Min	Max
.034	ULN>>	Enable Function		on	on/off		on/off	
.035	ULN>> off	U _{THR} OFF	%Unom	120	100	130	100	135
.036	ULN>> on	U _{THR} ON	%Unom	109	100	120	100	135
.037	T ULN>>	Time OFF	ms	100	100	5000	100	300000
		Time OFF	ms	Fixed to fastest possible disconnection				
Comment:		U LN > off has a fixed offset of 0.5% U _{NOM} subtracted from the displayed value						
Only active for:		Connection Modes: 2-wire, 4-wire (LN), 4-wire (LN+LL)						

Undervoltage2 Line to Neutral				Conformity Range		Possible Range		
ID				Default	Min	Max	Min	Max
.038	ULN<<	Enable Function		on	on/off		on/off	
.039	ULN<< off	U _{THR} OFF	%Unom	30	20	100	10	100
.040	ULN<< on	U _{THR} ON	%Unom	90	50	100	10	100
.041	T ULN<<	Time OFF	ms	100	100	5000	100	300000
Comment:		U LN < off has a fixed offset of 0.25% U _{NOM} added to the displayed value						
Only active for:		Connection Modes: 2-wire, 4-wire (LN), 4-wire (LN+LL)						

10 minutes average overvoltage				Conformity Range		Possible Range		
ID				Default	Min	Max	Min	Max
.042	Uavg	Enable function		on	on / off		on / off	
.043	Uavg off	U _{THR} OFF	%Unom	110	100	115	100	135
.044	Uavg on	U _{THR} ON	%Unom	109	100	115	100	135
		Time OFF	ms	Fixed to fastest possible disconnection				

Zero Voltage Line to Neutral				Conformity Range		Possible Range		
ID				Default	Min	Max	Min	Max
.115	Uzero >	Enable Function		off	on/off		on/off	
.116	Uzero> off	U _{THR} OFF	%Unom	20	1	100	1	100
.117	Uzero> on	U _{THR} ON	%Unom	15	1	100	1	100
.118	T Uzero >	Time OFF	ms	1500	200	100000	0	300000
Only active for:		Connection Modes: 4-wire (LN+LL)						

Residual Voltage (3 x Zero Voltage) Line to Neutral Activation of a narrower frequency window				Conformity Range		Possible Range		
ID				Default	Min	Max	Min	Max
.119	Ures-anfw>	Enable Function		off	on/off		on/off	
.120	U res > on	U _{THR} OFF	%Unom	5	2	20	2	200
.121	U res > off	U _{THR} ON	%Unom	3	1	20	1	100
.122	T Ures >	Time OFF	ms	200	0	240000	0	240000
Only active for:		Connection Modes: 4-wire (LN+LL)						

Undervoltage Line to Neutral Activation of a narrower frequency window				Conformity Range		Possible Range		
ID				Default	Min	Max	Min	Max
.123	Uanfw <	Enable Function		off	on/off		on/off	
.124	Uanfw< on	U _{THR} OFF	%Unom	85	21	100	2	100
.125	Uanfw< off	U _{THR} ON	%Unom	86	21	100	2	100
.126	T Uanfw <	Time OFF	ms	0	0	240000	0	240000
Only active for:		Connection Modes: 4-wire (LN+LL)						

Overfrequency1				Conformity Range		Possible Range		
ID				Default	Min	Max	Min	Max
.054	f >	Enable Function		on	on		on/off	
.055	f > off	f _{THR} OFF	Hz	51.50	50.00	52.00	50.00	55.00
.056	f > on	f _{THR} ON	Hz	50.10	50.00	52.00	50.00	55.00
.057	T f >	Time OFF	ms	100	100	100000	100	300000
Comment:		f > on has a fixed offset of 0.01 Hz subtracted to the displayed value						
Only active for:		Voltage > 20% U _{NOM}						

Underfrequency1				Conformity Range		Possible Range		
ID				Default	Min	Max	Min	Max
.058	f <	Enable Function		on	on		on/off	
.059	f < off	f _{THR} OFF	Hz	47.50	47.00	50.00	45.00	50.00
.060	f < on	f _{THR} ON	Hz	48.50	47.00	50.00	45.00	50.00
.061	T f <	Time OFF	ms	100	100	100000	100	300000
Comment:		f < on has a fixed offset of 0.01 Hz added to the displayed value						
Only active for:		Voltage > 20% U _{NOM}						

Overfrequency nw (narrower window)				Conformity Range		Possible Range		
ID				Default	Min	Max	Min	Max
.062	f nw >	Enable Function		off	on/off		on/off	
.063	f nw > off	f _{THR} OFF	Hz	50.30	50.00	52.00	50.00	55.00
.064	f nw > on	f _{THR} ON	Hz	50.10	50.00	52.00	50.00	55.00
.065	T f nw >	Time OFF	ms	500	100	5000	100	300000
Comment:		f nw > off has a fixed offset of 0.01 Hz subtracted to the displayed value						
Only active for:		Ures-anfw, Uanfw, Dig Input5=HIGH (local setting)						

Underfrequency nw (narrower window)				Conformity Range		Possible Range		
ID				Default	Min	Max	Min	Max
.066	f nw <	Enable Function		off	on/off		on/off	
.067	f nw < off	f _{THR} OFF	Hz	49.70	47.00	50.00	45.00	50.00
.068	f nw < on	f _{THR} ON	Hz	49.80	47.00	50.00	45.00	50.00
.069	T f nw <	Time OFF	ms	500	100	5000	100	300000
Comment:		f nw < off has a fixed offset of 0.01 Hz added to the displayed value						
Only active for:		Ures-anfw, Uanfw, Dig Input5=HIGH (local setting)						

Frequency measuring in general				Conformity Range		Possible Range		
ID				Default	Min	Max	Min	Max
.113	F wnd	Window length	ms	Fixed window length 100ms				

Rate of Change of Frequency (RoCoF)				Conformity Range		Possible Range		
ID				Default	Min	Max	Min	Max
.090	ROCOF	Enable Function		off	on / off		on / off	
.091	ROCOF off	RoCoF _{THR} OFF	mHz/s	1000	200	9990	100	9990
.092	ROCOF on	RoCoF _{THR} ON	mHz/s	800	100	9990	100	9990
.093	ROCOF t	Time OFF	ms	0	0	5000	0	5000
.111	RoCoF wnd	Window length	ms	Fixed window length 100ms				

Phase Shift (PShift)				Conformity Range		Possible Range		
ID				Default	Min	Max	Min	Max
.094	PShift	Enable Function		off	on / off		on / off	
.095	PShift off	PShift _{THR} OFF	°	7	2	15	2	15
.096	PShift on	PShift _{THR} ON	°	5	1	15	1	15
		Time OFF	ms	Fixed to the fastest possible disconnection				
.112	PShift wnd	Window length	ms	Fixed window length 100ms				
Comment:		PShift off has a fixed offset of 1° subtracted from the displayed value						

Auxiliary Contact type				Conformity Range		Possible Range		
ID			Default		Min	Max	Min	Max
.099	Contact	Type	dis. (disabled)		n.o. (normally opened) n.c. (normally closed) dis. (disabled)		n.o. (normally opened) n.c. (normally closed) dis. (disabled)	
.100	Contact t	Time OFF	ms	500				
.114	I3 STOP	Type	n.o. (normally opened)		n.o. (normally opened) n.c. (normally closed) dis. (disabled)		n.o. (normally opened) n.c. (normally closed) dis. (disabled)	

Turn-on delay				Conformity Range		Possible Range		
ID				Default	Min	Max	Min	Max
.102	T on delay	Turn on time	s	60	10	600	10	600

Password						
ID				Default	Min	Max
.106	PW1	1 st digit of Password		0	0	9
.107	PW2	2 nd digit of Password		0	0	9
.108	PW3	3 rd digit of Password		0	0	9
.109	PW4	4 th digit of Password		0	0	9
Remark:		If all 4 digits of the Password are 0 (default setting) the Password request is skipped				

Device Information		
ID		
.105	ID: xxxxxx SW: aa.dd.ccb	xxxxx = Device ID dd: Software version of Display Software aa: Software version of Measuring Software cc: Index of Configuration set b: Version of Configuration set

10.34 EN50438:2013 DK [ID 950]

Connection Mode			Conformity Range		Possible Range	
ID		Default				
.003	Connection	4-wire (LN)	3-wire, 4-wire (LN)		2-wire, 3-wire, 4-wire (LN), 4-wire (LN+LL)	

Nominal Voltage				Conformity Range		Possible Range	
ID		Default		Min	Max	Min	Max
.005	ULN/LL nom	Unom Y	V	230.0	230.0	100.0	240.0
		Unom Δ	V	400.0	400.0	173.9	417.4

Functional Safety			Conformity Range		Possible Range	
ID		Default				
.007	Errtol	2ch	2ch, 1ch		2ch, 1ch	
Remark:		2ch means: 2 channel with functional safety and 2 auxilliary contacts necessary 1ch means: 1 channel without functional safety and 1 auxilliary contact1 necessary				

Overvoltage1 Line to Line				Conformity Range		Possible Range	
ID		Default		Min	Max	Min	Max
.011	ULL max 1	U _{THR} OFF	%Unom	110	110	100	135
		U _{THR} ON	%Unom	Fixed Hysteresis (1% U _{NOM})			
.013	ULL max 1t	Time OFF	ms	39500	39500	50	60000
Only active for:		Connection Modes: 3-wire, 4-wire (LN+LL)					

Undervoltage1 Line to Line				Conformity Range		Possible Range	
ID		Default		Min	Max	Min	Max
.015	ULL min	U _{THR} OFF	%Unom	90	90	10	100
		U _{THR} ON	%Unom	Fixed Hysteresis (1% U _{NOM})			
.017	ULL min t	Time OFF	ms	9500	9500	50	60000
Only active for:		Connection Modes: 3-wire, 4-wire (LN+LL)					

Overvoltage1 Line to Neutral				Conformity Range		Possible Range	
ID		Default		Min	Max	Min	Max
.019	ULN max 1	U _{THR} OFF	%Unom	110	110	100	135
		U _{THR} ON	%Unom	Fixed Hysteresis (1% U _{NOM})			
.021	ULN max 1t	Time OFF	ms	39500	39500	50	60000
Only active for:		Connection Modes: 2-wire, 4-wire (LN), 4-wire (LN+LL)					

Undervoltage1 Line to Neutral				Conformity Range		Possible Range	
ID		Default		Min	Max	Min	Max
.023	ULN min	U _{THR} OFF	%Unom	90	90	10	100
		U _{THR} ON	%Unom	Fixed Hysteresis (1% U _{NOM})			
.025	ULN min t	Time OFF	ms	9500	9500	50	60000
Only active for:		Connection Modes: 2-wire, 4-wire (LN), 4-wire (LN+LL)					

Overvoltage2 Line to Line				Conformity Range		Possible Range	
ID		Default		Min	Max	Min	Max
.027	ULL max 2	U _{THR} OFF	%Unom	113	113	100	135
		U _{THR} ON	%Unom	Fixed Hysteresis (1% U _{NOM})			
		Time OFF	ms	Fixed to 100ms			
Only active for:		Connection Modes: 3-wire, 4-wire (LN+LL)					

Overvoltage2 Line to Neutral					Conformity Range		Possible Range	
ID				Default	Min	Max	Min	Max
.035	ULN max 2	U _{THR} OFF	%Unom	113	113	113	100	135
		U _{THR} ON	%Unom	Fixed Hysteresis (1% U _{NOM})				
		Time OFF	ms	Fixed to 100ms				
Only active for:		Connection Modes: 2-wire, 4-wire (LN), 4-wire (LN+LL)						

Overfrequency1					Conformity Range		Possible Range	
ID				Default	Min	Max	Min	Max
.055	f > off	f _{THR} OFF	Hz	52.00	52.00	52.00	50.00	55.00
.056	f > on	f _{THR} ON	Hz	50.05	50.05	50.05	50.00	55.00
		Time OFF	ms	Fixed to 150ms				

Underfrequency1					Conformity Range		Possible Range	
ID				Default	Min	Max	Min	Max
.059	f < off	f _{THR} OFF	Hz	47.50	47.50	47.50	45.00	50.00
.060	f < on	f _{THR} ON	Hz	47.50	47.50	47.50	45.00	50.00
		Time OFF	ms	Fixed to 150ms				
Comment:		f < on has a fixed offset of 0.025 Hz added to the displayed value						

Frequency measuring in general					Conformity Range		Possible Range	
ID				Default	Min	Max	Min	Max
.113	F wnd	Window length	ms	Fixed window length 100ms				

Rate of Change of Frequency (RoCoF)					Conformity Range		Possible Range	
ID				Default	Min	Max	Min	Max
.090	RoCoF	Enable Function		on	on / off		on / off	
.091	RoCoF off	RoCoF _{THR} OFF	mHz/s	2500	2500	2500	100	3000
.092	RoCoF on	RoCoF _{THR} ON	mHz/s	2300	2300	2300	100	3000
		Time OFF	ms	Fixed to the fastest possible disconnection				
.111	RoCoF wnd	Window length	ms	Fixed window length 200ms				

Auxiliary Contact type					Conformity Range		Possible Range	
ID				Default	Min	Max	Min	Max
.099	Contact	Type	n.c. (normally closed)		n.o. (normally opened) n.c. (normally closed)		n.o. (normally opened) n.c. (normally closed) dis. (disabled)	
.100	T Contact	Time OFF	ms	Fixed to 500ms				
.114	I3 STOP	Type	n.o. (normally opened)		n.o. (normally opened) n.c. (normally closed) dis. (disabled)		n.o. (normally opened) n.c. (normally closed) dis. (disabled)	

Turn-on delay					Conformity Range		Possible Range	
ID				Default	Min	Max	Min	Max
.102	Ton delay	Turn on time	s	60	60	60	0	600

Password					Default	Min	Max
ID							
.106	PW1	1 st digit of Password			0	0	9
.107	PW2	2 nd digit of Password			0	0	9
.108	PW3	3 rd digit of Password			0	0	9
.109	PW4	4 th digit of Password			0	0	9
Remark:		If all 4 digits of the Password are 0 (default setting) the Password request is skipped					

Device Information		
ID		
.105	ID: xxxxxx SW: aa.dd.ccb	xxxxx = Device ID dd: Software version of Display Software aa: Software version of Measuring Software cc: Index of Configuration set b: Version of Configuration set

10.35 VDE 0126-1-1:2013 [ID 200]

Connection Mode				Conformity Range		Possible Range		
ID	Default							
.003	Connection	Fixed to 4-wire (LN+LL)						

Nominal Voltage				Conformity Range		Possible Range	
ID	Default			Min	Max	Min	Max
.005	ULN/LL nom	Unom Y	V	Fixed to 230.0 / 400.0			
		Unom Δ	V				

Functional Safety				Conformity Range		Possible Range		
ID	Default							
.007	Errtol	Fixed to 2ch						
Remark:		2ch means: 2 channel with functional safety and 2 auxilliary contacts necessary						

Overvoltage1 Line to Line				Conformity Range		Possible Range	
ID	Default			Min	Max	Min	Max
.011	ULLmax off	U _{THR} OFF	%Unom	115	115	100	135
.012	ULLmax on	U _{THR} ON	%Unom	110	110	100	135
		Time OFF	ms	Fixed to fastest possible disconnection			
Comment:		ULLmax on has a fixed offset of 0.5% U _{NOM} subtracted from the displayed value					

Undervoltage1 Line to Line				Conformity Range		Possible Range	
ID	Default			Min	Max	Min	Max
.015	ULLmin off	U _{THR} OFF	%Unom	80	80	10	100
.016	ULLmin on	U _{THR} ON	%Unom	85	85	10	100
		Time OFF	ms	Fixed to fastest possible disconnection			
Comment:		ULLmin on has a fixed offset of 0.5% U _{NOM} added to the displayed value					

Overvoltage1 Line to Neutral				Conformity Range		Possible Range	
ID	Default			Min	Max	Min	Max
.019	U >> off	U _{THR} OFF	%Unom	115	115	100	135
.020	U >> on	U _{THR} ON	%Unom	110	110	100	135
		Time OFF	ms	Fixed to fastest possible disconnection			
Comment:		U >> on has a fixed offset of 0.5% U _{NOM} subtracted from the displayed value					

Undervoltage1 Line to Neutral				Conformity Range		Possible Range	
ID	Default			Min	Max	Min	Max
.023	U < off	U _{THR} OFF	%Unom	80	80	10	100
.024	U < on	U _{THR} ON	%Unom	85	85	10	100
		Time OFF	ms	Fixed to fastest possible disconnection			
Comment:		U < on has a fixed offset of 0.5% U _{NOM} added to the displayed value					

10 minutes average overvoltage				Conformity Range		Possible Range	
ID	Default			Min	Max	Min	Max
.043	U>	U _{THR} OFF	%Unom	110	115	100	135
		U _{THR} ON	%Unom	Fixed Hysteresis (0.9% U _{NOM})			
		Time OFF	ms	Fixed to fastest possible disconnection			

Overfrequency1				Conformity Range		Possible Range	
ID	Default			Min	Max	Min	Max
.055	f > off	f _{THR} OFF	Hz	51.50	51.50	50.00	55.00
.056	F > on	f _{THR} ON	Hz	50.05	50.05	50.00	55.00
		Time OFF	ms	Fixed to fastest possible disconnection			

Underfrequency1				Conformity Range		Possible Range		
ID				Default	Min	Max	Min	Max
.059	f < off	f _{THR} OFF	Hz	47.50	47.50	47.50	45.00	50.00
.060	f < on	f _{THR} ON	ms	47.50	47.50	47.50	45.00	50.00
		Time OFF	ms	Fixed to fastest possible disconnection				
Comment:		f < on has a fixed offset of 0.025 Hz added to the displayed value						

Random overfrequency				Conformity Range		Possible Range		
ID				Default	Min	Max	Min	Max
.086	f> random	Enable function		off	on / off		on / off	
.087	f> random	f _{THR} OFF	Hz		50.20	51.50	50.20	51.50
		f _{THR} ON	Hz	Fixed reconnection frequency of 50.05Hz				
		Time OFF	ms	Fixed to fastest possible disconnection				
Comment:		The random f _{THR} OFF threshold is shown in .087 and cannot be edited						

Frequency measuring in general				Conformity Range		Possible Range		
ID				Default	Min	Max	Min	Max
.113	F wnd	Window length	ms	Fixed window length 100ms				

Auxiliary Contact type				Conformity Range		Possible Range		
ID			Default		Min	Max	Min	Max
.099	Contact	Type	n.c. (normally closed)		n.o. (normally opened) n.c. (normally closed)		n.o. (normally opened) n.c. (normally closed) dis. (disabled)	
.100	T Contact	Time OFF	ms	Fixed to 500ms				
.114	I3 STOP	Type	n.o. (normally opened)		n.o. (normally opened) n.c. (normally closed) dis. (disabled)		n.o. (normally opened) n.c. (normally closed) dis. (disabled)	

Turn-on delay				Conformity Range		Possible Range		
ID				Default	Min	Max	Min	Max
.102	Ton delay	Turn on time	s	60	60	60	0	600

Random Turn-on delay				Conformity Range		Possible Range		
ID				Default	Min	Max	Min	Max
.103	Ton random	Enable function		off	on / off		on / off	
.104	Ton random	Turn on time	s		60	600	60	600
Comment:		The random time value is shown in .104 and cannot be edited						

Password				Default	Min	Max
ID						
.106	PW1	1 st digit of Password		0	0	9
.107	PW2	2 nd digit of Password		0	0	9
.108	PW3	3 rd digit of Password		0	0	9
.109	PW4	4 th digit of Password		0	0	9
Remark:		If all 4 digits of the Password are 0 (default setting) the Password request is skipped				

Device Information		
ID		
.105	ID: xxxxxx SW: aa.dd.ccb	xxxxx = Device ID dd: Software version of Display Software aa: Software version of Measuring Software cc: Index of Configuration set b: Version of Configuration set

10.36 AB AS 4777.2:2020 [ID 1110]

Connection Mode				Conformity Range		Possible Range	
ID		Default					
.003	Connection	4-wire (LN)		4-wire (LN)		2-wire, 3-wire, 4-wire (LN), 4-wire (LN+LL)	

Nominal Voltage				Conformity Range		Possible Range		
ID		Default		Min	Max	Min	Max	
.005	ULN/LL nom	Unom Y	V	230.0	230.0	240.0	100.0	240.0
		Unom Δ	V	400.0	400.0	417.4	173.9	417.4

Functional Safety				Conformity Range		Possible Range	
ID		Default					
.007	Errtol	Fixed to 2ch					
Remark:		2ch means: 2 channel with functional safety and 2 auxilliary contacts necessary					

Overvoltage1 Line to Neutral				Conformity Range		Possible Range	
ID		Default		Min	Max	Min	Max
.019	V> off	U _{THR} OFF	%Unom	115.2	115.2	100	135
.020	V> on	U _{THR} ON	%Unom	110	110	100	135
.021	T V>	Time OFF	ms	1000	1900	50	300000

Undervoltage1 Line to Neutral				Conformity Range		Possible Range	
ID		Default		Min	Max	Min	Max
.023	V< off	U _{THR} OFF	%Unom	78.3	78.3	0	100
.024	V< on	U _{THR} ON	%Unom	89	100	0	100
.025	T V<	Time OFF	ms	10000	10900	50	300000

Overvoltage2 Line to Neutral				Conformity Range		Possible Range	
ID		Default		Min	Max	Min	Max
.034	V>>	Enable function		on / off		on / off	
.035	V>> off	U _{THR} OFF	%Unom	119.6	119.6	100	135
.036	V>> on	U _{THR} ON	%Unom	110	110	100	135
.037	T V>>	Time OFF	ms	100	200	100	300000

Undervoltage2 Line to Neutral				Conformity Range		Possible Range	
ID		Default		Min	Max	Min	Max
.039	V<< off	U _{THR} OFF	%Unom	30.4	30.4	0	100
.040	V<< on	U _{THR} ON	%Unom	89	100	0	100
.041	T V<<	Time OFF	ms	1000	1900	50	300000

10 minutes average overvoltage				Conformity Range		Possible Range	
ID		Default		Min	Max	Min	Max
.042	Uavg	Enable function		on / off		on / off	
.043	Uavg off	U _{THR} OFF	%Unom	112.2	112.2	100	135
.044	Uavg on	U _{THR} ON	%Unom	110	110	100	135
		Time OFF	ms	Fixed to fastest possible disconnection			

Overfrequency1				Conformity Range		Possible Range	
ID		Default		Min	Max	Min	Max
.055	F> off	f _{THR} OFF	Hz	52.00	52.00	50.00	55.00
.056	F> on	f _{THR} ON	Hz	50.15	50.15	50.00	55.00
.057	T F>	Time OFF	ms	100	200	100	300000

Underfrequency1				Conformity Range		Possible Range		
ID				Default	Min	Max	Min	Max
.059	F< off	f _{THR} OFF	Hz	47.00	47.00	47.00	40.00	50.00
.060	F< on	f _{THR} ON	Hz	47.50	47.50	50.00	40.00	50.00
.061	T F<	Time OFF	ms	1000	1000	1900	50	300000

Frequency measuring in general				Conformity Range		Possible Range		
ID				Default	Min	Max	Min	Max
.113	F wnd	Window length	ms	Fixed window length 100ms				

Rate of Change of Frequency (RoCoF)				Conformity Range		Possible Range		
ID				Default	Min	Max	Min	Max
.090	RoCoF	Enable Function		off	on / off		on / off	
.091	RoCoF off	RoCoF _{THR} OFF	mHz/s	1000	10	9990	10	9990
.092	RoCoF on	RoCoF _{THR} ON	mHz/s	950	10	9990	10	9990
.093	RoCoFDelay	Time OFF	ms	500	50	500	50	10000
.111	RoCoF wnd	Window length	ms	225	100	1000	100	1000

Phase Shift (PShift)				Conformity Range		Possible Range		
ID				Default	Min	Max	Min	Max
.094	PShift	Enable Function		off	on / off		on / off	
.095	PShift off	PShift _{THR} OFF	°	8	1	8	1	15
.096	PShift on	PShift _{THR} ON	°	6	1	7	1	15
.097	PShiftDel	Time OFF	ms	50	50	50	50	10000
.112	PShift wnd	Window length	ms	50	50	500	50	1000

Auxiliary Contact type				Conformity Range		Possible Range		
ID				Default	Min	Max	Min	Max
.099	Contact	Type	n.c. (normally closed)	n.o. (normally opened) n.c. (normally closed)		n.o. (normally opened) n.c. (normally closed) dis. (disabled)		
.100	T Contact	Time OFF	ms	Fixed to 500ms				
.114	I3 STOP	Type	n.o. (normally opened)	n.o. (normally opened) n.c. (normally closed) dis. (disabled)		n.o. (normally opened) n.c. (normally closed) dis. (disabled)		

Turn-on delay				Conformity Range		Possible Range		
ID				Default	Min	Max	Min	Max
.102	Ton delay	Turn on time	s	60	0	60	0	600

Password						
ID				Default	Min	Max
.106	PW1	1 st digit of Password		0	0	9
.107	PW2	2 nd digit of Password		0	0	9
.108	PW3	3 rd digit of Password		0	0	9
.109	PW4	4 th digit of Password		0	0	9
Remark:		If all 4 digits of the Password are 0 (default setting) the Password request is skipped				

Device Information		
ID		
.105	ID: xxxxxx SW: aa.dd.ccb	xxxxx = Device ID dd: Software version of Display Software aa: Software version of Measuring Software cc: Index of Configuration set b: Version of Configuration set

10.37 C AS 4777.2:2020 [ID 1120]

Connection Mode				Conformity Range		Possible Range	
ID		Default					
.003	Connection	4-wire (LN)		4-wire (LN)		2-wire, 3-wire, 4-wire (LN), 4-wire (LN+LL)	

Nominal Voltage				Conformity Range		Possible Range		
ID		Default		Min	Max	Min	Max	
.005	ULN/LL nom	Unom Y	V	230.0	230.0	240.0	100.0	240.0
		Unom Δ	V	400.0	400.0	417.4	173.9	417.4

Functional Safety				Conformity Range		Possible Range	
ID		Default					
.007	Errtol	Fixed to 2ch					
Remark:		2ch means: 2 channel with functional safety and 2 auxilliary contacts necessary					

Overvoltage1 Line to Neutral				Conformity Range		Possible Range	
ID		Default		Min	Max	Min	Max
.019	V> off	U _{THR} OFF	%Unom	115.2	115.2	100	135
.020	V> on	U _{THR} ON	%Unom	110	110	100	135
.021	T V>	Time OFF	ms	1000	1900	50	300000

Undervoltage1 Line to Neutral				Conformity Range		Possible Range	
ID		Default		Min	Max	Min	Max
.023	V< off	U _{THR} OFF	%Unom	78.3	78.3	0	100
.024	V< on	U _{THR} ON	%Unom	89	100	0	100
.025	T V<	Time OFF	ms	10000	10900	50	300000

Overvoltage2 Line to Neutral				Conformity Range		Possible Range	
ID		Default		Min	Max	Min	Max
.034	V>>	Enable function		off		on / off	
.035	V>> off	U _{THR} OFF	%Unom	119.6	119.6	100	135
.036	V>> on	U _{THR} ON	%Unom	110	110	100	135
.037	T V>>	Time OFF	ms	100	200	100	300000

Undervoltage2 Line to Neutral				Conformity Range		Possible Range	
ID		Default		Min	Max	Min	Max
.039	V<< off	U _{THR} OFF	%Unom	30.4	30.4	0	100
.040	V<< on	U _{THR} ON	%Unom	89	100	0	100
.041	T V<<	Time OFF	ms	1000	1900	50	300000

10 minutes average overvoltage				Conformity Range		Possible Range	
ID		Default		Min	Max	Min	Max
.042	Uavg	Enable function		on		on / off	
.043	Uavg off	U _{THR} OFF	%Unom	112.2	112.2	100	135
.044	Uavg on	U _{THR} ON	%Unom	110	110	100	135
		Time OFF	ms	Fixed to fastest possible disconnection			

Overfrequency1				Conformity Range		Possible Range	
ID		Default		Min	Max	Min	Max
.055	F> off	f _{THR} OFF	Hz	55.00	55.00	50.00	55.00
.056	F> on	f _{THR} ON	Hz	50.15	50.15	50.00	55.00
.057	T F>	Time OFF	ms	100	200	100	300000

Underfrequency1				Conformity Range		Possible Range		
ID				Default	Min	Max	Min	Max
.059	F< off	f _{THR} OFF	Hz	45.00	45.00	45.00	40.00	50.00
.060	F< on	f _{THR} ON	Hz	47.50	47.50	50.00	40.00	50.00
.061	T F<	Time OFF	ms	5000	5000	5900	50	300000

Frequency measuring in general				Conformity Range		Possible Range		
ID				Default	Min	Max	Min	Max
.113	F wnd	Window length	ms	Fixed window length 100ms				

Rate of Change of Frequency (RoCoF)				Conformity Range		Possible Range		
ID				Default	Min	Max	Min	Max
.090	RoCoF	Enable Function		off	on / off		on / off	
.091	RoCoF off	RoCoF _{THR} OFF	mHz/s	1000	10	9990	10	9990
.092	RoCoF on	RoCoF _{THR} ON	mHz/s	950	10	9990	10	9990
.093	RoCoFDelay	Time OFF	ms	500	50	500	50	10000
.111	RoCoF wnd	Window length	ms	225	100	1000	100	1000

Phase Shift (PShift)				Conformity Range		Possible Range		
ID				Default	Min	Max	Min	Max
.094	PShift	Enable Function		off	on / off		on / off	
.095	PShift off	PShift _{THR} OFF	°	8	1	8	1	15
.096	PShift on	PShift _{THR} ON	°	6	1	7	1	15
.097	PShiftDel	Time OFF	ms	50	50	50	50	10000
.112	PShift wnd	Window length	ms	50	50	500	50	1000

Auxiliary Contact type				Conformity Range		Possible Range		
ID				Default	Min	Max	Min	Max
.099	Contact	Type	n.c. (normally closed)		n.o. (normally opened) n.c. (normally closed)		n.o. (normally opened) n.c. (normally closed) dis. (disabled)	
.100	T Contact	Time OFF	ms	Fixed to 500ms				
.114	I3 STOP	Type	n.o. (normally opened)		n.o. (normally opened) n.c. (normally closed) dis. (disabled)		n.o. (normally opened) n.c. (normally closed) dis. (disabled)	

Turn-on delay				Conformity Range		Possible Range		
ID				Default	Min	Max	Min	Max
.102	Ton delay	Turn on time	s	60	0	60	0	600

Password				Default	Min	Max
ID						
.106	PW1	1 st digit of Password		0	0	9
.107	PW2	2 nd digit of Password		0	0	9
.108	PW3	3 rd digit of Password		0	0	9
.109	PW4	4 th digit of Password		0	0	9
Remark:		If all 4 digits of the Password are 0 (default setting) the Password request is skipped				

Device Information		
ID		
.105	ID: xxxxxx SW: aa.dd.ccb	xxxxx = Device ID dd: Software version of Display Software aa: Software version of Measuring Software cc: Index of Configuration set b: Version of Configuration set

10.38 NZS 4777.2:2020 [ID 1130]

Connection Mode				Conformity Range		Possible Range	
ID		Default					
.003	Connection	4-wire (LN)		4-wire (LN)		2-wire, 3-wire, 4-wire (LN), 4-wire (LN+LL)	

Nominal Voltage				Conformity Range		Possible Range		
ID		Default		Min	Max	Min	Max	
.005	ULN/LL nom	Unom Y	V	230.0	230.0	240.0	100.0	240.0
		Unom Δ	V	400.0	400.0	417.4	173.9	417.4

Functional Safety				Conformity Range		Possible Range	
ID		Default					
.007	Errtol	Fixed to 2ch					
Remark:		2ch means: 2 channel with functional safety and 2 auxilliary contacts necessary					

Overvoltage1 Line to Neutral				Conformity Range		Possible Range	
ID		Default		Min	Max	Min	Max
.019	V> off	U _{THR} OFF	%Unom	115.2	115.2	100	135
.020	V> on	U _{THR} ON	%Unom	110	110	100	135
.021	T V>	Time OFF	ms	1000	1900	50	300000

Undervoltage1 Line to Neutral				Conformity Range		Possible Range	
ID		Default		Min	Max	Min	Max
.023	V< off	U _{THR} OFF	%Unom	78.3	78.3	0	100
.024	V< on	U _{THR} ON	%Unom	89	100	0	100
.025	T V<	Time OFF	ms	10000	10900	50	300000

Overvoltage2 Line to Neutral				Conformity Range		Possible Range	
ID		Default		Min	Max	Min	Max
.034	V>>	Enable function		on / off		on / off	
.035	V>> off	U _{THR} OFF	%Unom	119.6	119.6	100	135
.036	V>> on	U _{THR} ON	%Unom	110	110	100	135
.037	T V>>	Time OFF	ms	100	200	100	300000

Undervoltage2 Line to Neutral				Conformity Range		Possible Range	
ID		Default		Min	Max	Min	Max
.039	V<< off	U _{THR} OFF	%Unom	30.4	30.4	0	100
.040	V<< on	U _{THR} ON	%Unom	89	100	0	100
.041	T V<<	Time OFF	ms	1000	1900	50	300000

10 minutes average overvoltage				Conformity Range		Possible Range	
ID		Default		Min	Max	Min	Max
.042	Uavg	Enable function		on / off		on / off	
.043	Uavg off	U _{THR} OFF	%Unom	108.3	112.2	100	135
.044	Uavg on	U _{THR} ON	%Unom	106.1	110	100	135
		Time OFF	ms	Fixed to fastest possible disconnection			

Overfrequency1				Conformity Range		Possible Range	
ID		Default		Min	Max	Min	Max
.055	F> off	f _{THR} OFF	Hz	55.00	55.00	50.00	55.00
.056	F> on	f _{THR} ON	Hz	50.15	50.15	50.00	55.00
.057	T F>	Time OFF	ms	100	200	100	300000

Underfrequency1				Conformity Range		Possible Range		
ID				Default	Min	Max	Min	Max
.059	F< off	f _{THR} OFF	Hz	45.00	45.00	45.00	40.00	50.00
.060	F< on	f _{THR} ON	Hz	47.50	47.50	50.00	40.00	50.00
.061	T F<	Time OFF	ms	1000	1000	1900	50	300000

Frequency measuring in general				Conformity Range		Possible Range		
ID				Default	Min	Max	Min	Max
.113	F wnd	Window length	ms	Fixed window length 100ms				

Rate of Change of Frequency (RoCoF)				Conformity Range		Possible Range		
ID				Default	Min	Max	Min	Max
.090	RoCoF	Enable Function		off	on / off		on / off	
.091	RoCoF off	RoCoF _{THR} OFF	mHz/s	1000	10	9990	10	9990
.092	RoCoF on	RoCoF _{THR} ON	mHz/s	950	10	9990	10	9990
.093	RoCoFDelay	Time OFF	ms	500	50	500	50	10000
.111	RoCoF wnd	Window length	ms	225	100	1000	100	1000

Phase Shift (PShift)				Conformity Range		Possible Range		
ID				Default	Min	Max	Min	Max
.094	PShift	Enable Function		off	on / off		on / off	
.095	PShift off	PShift _{THR} OFF	°	8	1	8	1	15
.096	PShift on	PShift _{THR} ON	°	6	1	7	1	15
.097	PShiftDel	Time OFF	ms	50	50	50	50	10000
.112	PShift wnd	Window length	ms	50	50	500	50	1000

Auxiliary Contact type				Conformity Range		Possible Range		
ID				Default	Min	Max	Min	Max
.099	Contact	Type	n.c. (normally closed)		n.o. (normally opened) n.c. (normally closed)		n.o. (normally opened) n.c. (normally closed) dis. (disabled)	
.100	T Contact	Time OFF	ms	Fixed to 500ms				
.114	I3 STOP	Type	n.o. (normally opened)		n.o. (normally opened) n.c. (normally closed) dis. (disabled)		n.o. (normally opened) n.c. (normally closed) dis. (disabled)	

Turn-on delay				Conformity Range		Possible Range		
ID				Default	Min	Max	Min	Max
.102	Ton delay	Turn on time	s	60	0	60	0	600

Password				Default	Min	Max
ID						
.106	PW1	1 st digit of Password		0	0	9
.107	PW2	2 nd digit of Password		0	0	9
.108	PW3	3 rd digit of Password		0	0	9
.109	PW4	4 th digit of Password		0	0	9
Remark:		If all 4 digits of the Password are 0 (default setting) the Password request is skipped				

Device Information		
ID		
.105	ID: xxxxxx SW: aa.dd.ccb	xxxxx = Device ID dd: Software version of Display Software aa: Software version of Measuring Software cc: Index of Configuration set b: Version of Configuration set

10.39 NRS 097-2-1:2017 [ID 1000]

Connection Mode				Conformity Range		Possible Range	
ID		Default					
.003	Connection	4-wire (LN)		2-wire, 3-wire, 4-wire (LN), 4-wire (LN+LL)		2-wire, 3-wire, 4-wire (LN), 4-wire (LN+LL)	

Nominal Voltage				Conformity Range		Possible Range	
ID		Default		Min	Max	Min	Max
.005	ULN/LL nom	Unom Y	V	230.0	230.0	28.8	250.0
		Unom Δ	V	400.0	400.0	50.0	434.8

Functional Safety			Conformity Range		Possible Range		
ID		Default					
.007	Errtol	Fixed to 2ch					
Remark:		2ch means: 2 channel with functional safety and 2 auxilliary contacts necessary					

Overvoltage1 Line to Line				Conformity Range		Possible Range	
ID		Default		Min	Max	Min	Max
.011	ULL>1 OFF	U _{THR} OFF	%Unom	111	111	100	135
.012	ULL>1 ON	U _{THR} ON	%Unom	109	109	100	135
.013	ULL>1 T	Time OFF	ms	2000	200	200	60000
Comment:		ULL>1 OFF has a fixed offset of 0.5% U _{NOM} subtracted from the displayed value					
Only active for:		Connection Modes: 3-wire, 4-wire (LN+LL)					

Undervoltage1 Line to Line				Conformity Range		Possible Range	
ID		Default		Min	Max	Min	Max
.015	ULL<1 OFF	U _{THR} OFF	%Unom	84	84	10	100
.016	ULL<1 ON	U _{THR} ON	%Unom	86	100	10	100
.017	ULL<1 T	Time OFF	ms	10000	600	200	60000
Comment:		ULL<1 OFF has a fixed offset of 0.5% U _{NOM} added to the displayed value					
Only active for:		Connection Modes: 3-wire, 4-wire (LN+LL)					

Overvoltage1 Line to Neutral				Conformity Range		Possible Range	
ID		Default		Min	Max	Min	Max
.019	ULN>1 OFF	U _{THR} OFF	%Unom	111	111	100	135
.020	ULN>1 ON	U _{THR} ON	%Unom	109	109	100	135
.021	ULN>1 T	Time OFF	ms	2000	200	200	60000
Comment:		ULN>1 OFF has a fixed offset of 0.5% U _{NOM} subtracted from the displayed value					
Only active for:		Connection Modes: 2-wire, 4-wire (LN), 4-wire (LN+LL)					

Undervoltage1 Line to Neutral				Conformity Range		Possible Range	
ID		Default		Min	Max	Min	Max
.023	ULN<1 OFF	U _{THR} OFF	%Unom	84	84	10	100
.024	ULN<1 ON	U _{THR} ON	%Unom	86	100	10	100
.025	ULN<1 T	Time OFF	ms	10000	600	200	60000
Comment:		ULN<1 OFF has a fixed offset of 0.5% U _{NOM} added to the displayed value					
Only active for:		Connection Modes: 2-wire, 4-wire (LN), 4-wire (LN+LL)					

Overvoltage2 Line to Line				Conformity Range		Possible Range	
ID		Default		Min	Max	Min	Max
.027	ULL>2 OFF	U _{THR} OFF	%Unom	121	121	100	135
.028	ULL>2 ON	U _{THR} ON	%Unom	119	119	100	135
.029	ULL>2 T	Time OFF	ms	160	110	110	60000
Comment:		ULL>2 OFF has a fixed offset of 0.5% U _{NOM} subtracted from the displayed value					
Only active for:		Connection Modes: 3-wire, 4-wire (LN+LL)					

Undervoltage2 Line to Line				Conformity Range		Possible Range		
ID				Default	Min	Max	Min	Max
.031	ULL<2 OFF	U _{THR} OFF	%Unom	49	49	49	10	100
.032	ULL<2 ON	U _{THR} ON	%Unom	51	51	100	10	100
.033	ULL<2 T	Time OFF	ms	200	150	200	150	60000
Comment:		ULL<2 OFF has a fixed offset of 0.5% U _{NOM} added to the displayed value						
Only active for:		Connection Modes: 3-wire, 4-wire (LN+LL)						

Overvoltage2 Line to Neutral				Conformity Range		Possible Range		
ID				Default	Min	Max	Min	Max
.035	ULN>2 OFF	U _{THR} OFF	%Unom	121	121	121	100	135
.036	ULN>2 ON	U _{THR} ON	%Unom	119	100	119	100	135
.037	ULN>2 T	Time OFF	ms	160	110	160	110	60000
Comment:		ULN>2 OFF has a fixed offset of 0.5% U _{NOM} added to the displayed value						
Only active for:		Connection Modes: 2-wire, 4-wire (LN), 4-wire (LN+LL)						

Undervoltage2 Line to Neutral				Conformity Range		Possible Range		
ID				Default	Min	Max	Min	Max
.039	ULN<2 OFF	U _{THR} OFF	%Unom	49	49	49	10	100
.040	ULN<2 ON	U _{THR} ON	%Unom	51	51	100	10	100
.041	ULN<2 T	Time OFF	ms	200	150	200	150	60000
Comment:		ULN<2 OFF has a fixed offset of 0.5% U _{NOM} added to the displayed value						
Only active for:		Connection Modes: 2-wire, 4-wire (LN), 4-wire (LN+LL)						

Overfrequency1				Conformity Range		Possible Range		
ID				Default	Min	Max	Min	Max
.055	f>1 OFF	f _{THR} OFF	Hz	52.00	52.00	52.00	50.00	60.00
.056	f>1 ON	f _{THR} ON	Hz	50.50	50.00	50.50	50.00	60.00
.057	f>1 T	Time OFF	ms	4000	4000	4000	200	60000

Underfrequency1				Conformity Range		Possible Range		
ID				Default	Min	Max	Min	Max
.059	f<1 OFF	f _{THR} OFF	Hz	47.00	47.00	47.00	40.00	50.00
.060	f<1 ON	f _{THR} ON	Hz	47.10	47.10	50.00	40.00	50.00
.061	f<1 T	Time OFF	ms	200	200	200	200	60000

Random overfrequency				Conformity Range		Possible Range		
ID				Default	Min	Max	Min	Max
.086	f>RND	Enable function		off	on / off		on / off	
.087	f>RND OFF	f _{THR} OFF	Hz		50.50	52.00	50.50	52.00
.088	f>RND ON	f _{THR} ON	Hz	50.10	50.00	50.49	50.00	50.49
.089	f>RND T	Time OFF	ms	4000	4000	4000	50	60000
Comment:		The random f _{THR} OFF threshold is shown in .087 and cannot be edited						

Frequency measuring in general				Conformity Range		Possible Range		
ID				Default	Min	Max	Min	Max
.113	F wnd	Window length	ms	Fixed window length 100ms				

Rate of Change of Frequency (RoCoF)				Conformity Range		Possible Range		
ID				Default	Min	Max	Min	Max
.090	RoCoF	Enable Function		off	on / off		on / off	
.091	RoCoF OFF	RoCoF _{THR} OFF	mHz/s	1000	10	9990	10	9990
.092	RoCoF ON	RoCoF _{THR} ON	mHz/s	950	10	9990	100	9990
.093	RoCoFDelay	Time OFF	ms	500	50	60000	50	60000
.111	RoCoF wnd	Window length	ms	Fixed window length 225ms				

Phase Shift (PShift)				Conformity Range		Possible Range		
ID				Default	Min	Max	Min	Max
.094	PShift	Enable Function		off	on / off		on / off	
.095	PShift OFF	PShift _{THR} OFF	°	7	2	20	2	20
.096	PShift ON	PShift _{THR} ON	°	5	2	20	2	20
.097	PShift T	Time OFF	ms	0	0	60000	0	60000
.112	PShift wnd	Window length	ms	Fixed window length 200ms				

Auxiliary Contact type				Conformity Range		Possible Range		
ID				Default	Min	Max	Min	Max
.099	Contact	Type	n.c. (normally closed)		n.o. (normally opened) n.c. (normally closed)		n.o. (normally opened) n.c. (normally closed) dis. (disabled)	
.100	T Contact	Time OFF	ms	Fixed to 500ms				
.114	I3 STOP	Type	n.o. (normally opened)		n.o. (normally opened) n.c. (normally closed) dis. (disabled)		n.o. (normally opened) n.c. (normally closed) dis. (disabled)	

Turn-on delay				Conformity Range		Possible Range		
ID				Default	Min	Max	Min	Max
.102	Ton delay	Turn on time	s	60	60	600	0	600

Random Turn-on delay				Conformity Range		Possible Range		
ID				Default	Min	Max	Min	Max
.103	Ton random	Enable function		off	on / off		on / off	
.104	Ton random	Turn on time	s		60	600	60	600
Comment:		The random time value is shown in .104 and cannot be edited						

Password						
ID				Default	Min	Max
.106	PW1	1 st digit of Password		0	0	9
.107	PW2	2 nd digit of Password		0	0	9
.108	PW3	3 rd digit of Password		0	0	9
.109	PW4	4 th digit of Password		0	0	9
Remark:		If all 4 digits of the Password are 0 (default setting) the Password request is skipped				

Device Information		
ID		
.105	ID: xxxxxx	xxxxx = Device ID
	SW: aa.dd.ccb	dd: Software version of Display Software aa: Software version of Measuring Software cc: Index of Configuration set b: Version of Configuration set

10.40 OPEN SETUP [ID 9006]

Connection Mode			Conformity Range		Possible Range	
ID		Default				
.003	Connection	4-wire (LN)	2-wire, 3-wire, 4-wire (LN), 4-wire (LN+LL)		2-wire, 3-wire, 4-wire (LN), 4-wire (LN+LL)	

Nominal Voltage				Conformity Range		Possible Range		
ID		Default		Min	Max	Min	Max	
.005	ULN/LL nom	Unom Y	V	230.0	28.8	250.0	28.8	250.0
		Unom Δ	V	400.0	50.0	434.8	50.0	434.8

Functional Safety			Conformity Range		Possible Range	
ID		Default				
.007	Errtol	2ch	2ch, 1ch		2ch, 1ch	
Remark:		2ch means: 2 channel with functional safety and 2 auxilliary contacts necessary 1ch means: 1 channel without functional safety and 1 auxilliary contact1 necessary				

Overvoltage ¹ Line to Line				Conformity Range		Possible Range		
ID		Default		Min	Max	Min	Max	
.010	ULL>1	Enable function		on		on / off		
.011	ULL>1 OFF	U _{THR} OFF	%Unom	110	0	180	0	180
.012	ULL>1 ON	U _{THR} ON	%Unom	109	0	180	0	180
.013	ULL>1 T	Time OFF	ms	200	50	300000	50	300000
Only active for:		Connection Modes: 3-wire, 4-wire (LN+LL)						

Undervoltage ¹ Line to Line				Conformity Range		Possible Range		
ID		Default		Min	Max	Min	Max	
.014	ULL<1	Enable function		on		on / off		
.015	ULL<1 OFF	U _{THR} OFF	%Unom	90	0	180	0	180
.016	ULL<1 ON	U _{THR} ON	%Unom	91	0	180	0	180
.017	ULL<1 T	Time OFF	ms	200	50	300000	50	300000
Only active for:		Connection Modes: 3-wire, 4-wire (LN+LL)						

Overvoltage ¹ Line to Neutral				Conformity Range		Possible Range		
ID		Default		Min	Max	Min	Max	
.018	ULN>1	Enable function		on		on / off		
.019	ULN>1 OFF	U _{THR} OFF	%Unom	110	0	180	0	180
.020	ULN>1 ON	U _{THR} ON	%Unom	109	0	180	0	180
.021	ULN>1 T	Time OFF	ms	200	50	300000	50	300000
Only active for:		Connection Modes: 2-wire, 4-wire (LN), 4-wire (LN+LL)						

Undervoltage ¹ Line to Neutral				Conformity Range		Possible Range		
ID		Default		Min	Max	Min	Max	
.022	ULN<1	Enable function		on		on / off		
.023	ULN<1 OFF	U _{THR} OFF	%Unom	90	0	180	0	180
.024	ULN<1 ON	U _{THR} ON	%Unom	91	0	180	0	180
.025	ULN<1 T	Time OFF	ms	200	50	300000	50	300000
Only active for:		Connection Modes: 2-wire, 4-wire (LN), 4-wire (LN+LL)						

Overvoltage2 Line to Line				Conformity Range		Possible Range		
ID				Default	Min	Max	Min	Max
.026	ULL>2	Enable function		on	on / off		on /off	
.027	ULL>2 OFF	U _{THR} OFF	%Unom	120	0	180	0	180
.028	ULL>2 ON	U _{THR} ON	%Unom	119	0	180	0	180
.029	ULL>2 T	Time OFF	ms	100	50	300000	50	300000
Only active for:		Connection Modes: 3-wire, 4-wire (LN+LL)						

Undervoltage2 Line to Line				Conformity Range		Possible Range		
ID				Default	Min	Max	Min	Max
.030	ULL<2	Enable function		on	on / off		on /off	
.031	ULL<2 OFF	U _{THR} OFF	%Unom	80	0	180	0	180
.032	ULL<2 ON	U _{THR} ON	%Unom	81	0	180	0	180
.033	ULL<2 T	Time OFF	ms	100	50	300000	50	300000
Only active for:		Connection Modes: 3-wire, 4-wire (LN+LL)						

Overvoltage2 Line to Neutral				Conformity Range		Possible Range		
ID				Default	Min	Max	Min	Max
.034	ULN>2	Enable function		on	on / off		on /off	
.035	ULN>2 OFF	U _{THR} OFF	%Unom	120	0	180	0	180
.036	ULN>2 ON	U _{THR} ON	%Unom	119	0	180	0	180
.037	ULN>2 T	Time OFF	ms	100	50	300000	50	300000
Only active for:		Connection Modes: 2-wire, 4-wire (LN), 4-wire (LN+LL)						

Undervoltage2 Line to Neutral				Conformity Range		Possible Range		
ID				Default	Min	Max	Min	Max
.038	ULN<2	Enable function		on	on / off		on /off	
.039	ULN<2 OFF	U _{THR} OFF	%Unom	80	0	180	0	180
.040	ULN<2 ON	U _{THR} ON	%Unom	81	0	180	0	180
.041	ULN<2 T	Time OFF	ms	100	50	300000	50	300000
Only active for:		Connection Modes: 2-wire, 4-wire (LN), 4-wire (LN+LL)						

10 minutes average overvoltage				Conformity Range		Possible Range		
ID				Default	Min	Max	Min	Max
.042	UAVG>	Enable function		on	on / off		on /off	
.043	UAVG> OFF	U _{THR} OFF	%Unom	110	0	180	0	180
.044	UAVG> ON	U _{THR} ON	%Unom	109	0	180	0	180
.045	UAVG> T	Time OFF	ms	0	0	300000	0	300000

Deactivation frequency monitoring LL				Conformity Range		Possible Range		
ID				Default	Min	Max	Min	Max
.046	fdeac ULL<	Enable function		off	on / off		on /off	
.047	ULL< OFF	U _{THR} OFF	%Unom	9.5	9.5	60	2	100
		U _{THR} ON	%Unom	Fixed Hysteresis (1% U _{NOM})				

Deactivation frequency monitoring LN				Conformity Range		Possible Range		
ID				Default	Min	Max	Min	Max
.050	fdeac ULN<	Enable function		off	on / off		on /off	
.051	ULN< OFF	U _{THR} OFF	%Unom	9.5	9.5	60	2	100
		U _{THR} ON	%Unom	Fixed Hysteresis (1% U _{NOM})				

Overfrequency1					Conformity Range		Possible Range	
ID				Default	Min	Max	Min	Max
.054	f>1	Enable function		on	on / off		on / off	
.055	f>1 OFF	f _{THR} OFF	Hz	51.00	40.00	65.00	40.00	65.00
.056	f>1 ON	f _{THR} ON	Hz	50.90	40.00	65.00	40.00	65.00
.057	f>1 T	Time OFF	ms	200	75	300000	75	300000

Underfrequency1					Conformity Range		Possible Range	
ID				Default	Min	Max	Min	Max
.058	f<1	Enable function		on	on / off		on / off	
.059	f<1 OFF	f _{THR} OFF	Hz	49.00	40.00	65.00	40.00	65.00
.060	f<1 ON	f _{THR} ON	Hz	49.10	40.00	65.00	40.00	65.00
.061	f<1 T	Time OFF	ms	200	75	300000	75	300000

Overfrequency2					Conformity Range		Possible Range	
ID				Default	Min	Max	Min	Max
.062	f>2	Enable function		on	on / off		on / off	
.063	f>2 OFF	f _{THR} OFF	Hz	52.00	40.00	65.00	40.00	65.00
.064	f>2 ON	f _{THR} ON	Hz	51.90	40.00	65.00	40.00	65.00
.065	f>1 T	Time OFF	ms	100	75	300000	75	300000

Underfrequency2					Conformity Range		Possible Range	
ID				Default	Min	Max	Min	Max
.066	f<2	Enable function		on	on / off		on / off	
.067	f<2 OFF	f _{THR} OFF	Hz	48.00	40.00	65.00	40.00	65.00
.068	f<2 ON	f _{THR} ON	Hz	48.10	40.00	65.00	40.00	65.00
.069	f<2 T	Time OFF	ms	100	75	300000	75	300000

Random overfrequency					Conformity Range		Possible Range	
ID				Default	Min	Max	Min	Max
.086	f>RND	Enable function		off	on / off		on / off	
.087	f>RND OFF	f _{THR} OFF	Hz		50.20	51.50	50.20	51.50
.088	f>RND ON	f _{THR} ON	Hz	50.05	50.00	50.19	50.00	50.19
.089	f>RND T	Time OFF	ms	100	50	300000	50	300000

Comment: The random f_{THR} OFF threshold is shown in .087 and cannot be edited

Frequency measuring in general					Conformity Range		Possible Range	
ID				Default	Min	Max	Min	Max
.113	F wnd	Window length	ms	100	100	1000	100	1000

Rate of Change of Frequency (RoCoF)					Conformity Range		Possible Range	
ID				Default	Min	Max	Min	Max
.090	RoCoF	Enable Function		off	on / off		on / off	
.091	RoCoF OFF	RoCoF _{THR} OFF	mHz/s	1000	10	9990	10	9990
.092	RoCoF ON	RoCoF _{THR} ON	mHz/s	950	10	9990	10	9990
.093	RoCoFDelay	Time OFF	ms	500	50	300000	50	300000
.111	RoCoF wnd	Window length	ms	225	100	1000	100	1000

Phase Shift (PShift)					Conformity Range		Possible Range	
ID				Default	Min	Max	Min	Max
.094	PShift	Enable Function		off	on / off		on / off	
.095	PShift OFF	PShift _{THR} OFF	°	7	2	20	2	20
.096	PShift ON	PShift _{THR} ON	°	5	2	20	2	20
.097	PShift T	Time OFF	ms	0	0	300000	0	300000
.112	PShift wnd	Window length	ms	200	50	500	50	1000

Auxiliary Contact type				Conformity Range		Possible Range		
ID			Default		Min	Max	Min	Max
.099	Contact	Type	n.c. (normally closed)		n.o. (normally opened)		n.o. (normally opened)	
					n.c. (normally closed)		n.c. (normally closed)	
					dis. (disabled)		dis. (disabled)	
.100	T Contact	Time OFF	ms	Fixed to 500ms				
.114	I3 STOP	Type	n.o. (normally opened)		n.o. (normally opened)		n.o. (normally opened)	
					n.c. (normally closed)		n.c. (normally closed)	
					dis. (disabled)		dis. (disabled)	

Turn-on delay				Conformity Range		Possible Range		
ID			Default	Min	Max	Min	Max	
.102	Ton delay	Turn on time	s	60	0	600	0	600

Random Turn-on delay				Conformity Range		Possible Range		
ID			Default	Min	Max	Min	Max	
.103	Ton random	Enable function		off	on / off		on / off	
.104	Ton random	Turn on time	s		60	600	60	600
Comment:		The random time value is shown in .104 and cannot be edited						

Password					Min	Max
ID			Default			
.106	PW1	1 st digit of Password		0	0	9
.107	PW2	2 nd digit of Password		0	0	9
.108	PW3	3 rd digit of Password		0	0	9
.109	PW4	4 th digit of Password		0	0	9
Remark:		If all 4 digits of the Password are 0 (default setting) the Password request is skipped				

Device Information		
ID		
.105	ID: xxxxxx SW: aa.dd.ccb	xxxxx = Device ID dd: Software version of Display Software aa: Software version of Measuring Software cc: Index of Configuration set b: Version of Configuration set

10.41 EN50438:2013 [ID 900]

Connection Mode			Conformity Range		Possible Range	
ID		Default				
.003	Connection	Fixed to 4-wire (LN)				

Nominal Voltage				Conformity Range		Possible Range	
ID		Default		Min	Max	Min	Max
.005	ULN/LL nom	Unom Y	V	230.0	230.0	100.0	240.0
		Unom Δ	V	400.0	400.0	173.9	417.4

Functional Safety			Conformity Range		Possible Range	
ID		Default				
.007	Errtol	Fixed to 2ch				
Remark:		2ch means: 2 channel with functional safety and 2 auxilliary contacts necessary				

Overvoltage1 Line to Neutral				Conformity Range		Possible Range	
ID		Default		Min	Max	Min	Max
.019	U > off	U _{THR OFF}	%Unom	115	115	100	135
.020	U > on	U _{THR ON}	%Unom	110	110	100	135
		Time OFF	ms	Fixed to 100ms			
Comment:		U > on has a fixed offset of 0.5% U _{NOM} subtracted from the displayed value					

Undervoltage1 Line to Neutral				Conformity Range		Possible Range	
ID		Default		Min	Max	Min	Max
.023	U < off	U _{THR OFF}	%Unom	85	85	10	100
.024	U < on	U _{THR ON}	%Unom	85	85	10	100
.025	U < t	Time OFF	ms	1300	1300	50	10000
Comment:		U < on has a fixed offset of 0.5% U _{NOM} added to the displayed value					

10 minutes average overvoltage				Conformity Range		Possible Range	
ID		Default		Min	Max	Min	Max
.043	U avg off	U _{THR OFF}	%Unom	110	110	100	135
		U _{THR ON}	%Unom	Fixed Hysteresis (0.9% U _{NOM})			
		Time OFF	ms	Fixed to fastest possible disconnection			

Overfrequency1				Conformity Range		Possible Range	
ID		Default		Min	Max	Min	Max
.055	f > off	f _{THR OFF}	Hz	52.00	52.00	50.00	55.00
.056	f > on	f _{THR ON}	Hz	50.05	50.05	50.00	55.00
.057	f > t	Time OFF	ms	400	400	50	10000

Underfrequency1				Conformity Range		Possible Range	
ID		Default		Min	Max	Min	Max
.059	f < off	f _{THR OFF}	Hz	47.50	47.50	45.00	50.00
.060	f < on	f _{THR ON}	Hz	47.50	47.50	45.00	50.00
.061	f < t	Time OFF	ms	400	400	50	10000
Comment:		f < on has a fixed offset of 0.025 Hz added to the displayed value					

Frequency measuring in general				Conformity Range		Possible Range	
ID		Default		Min	Max	Min	Max
.113	F wnd	Window length	ms	Fixed window length 100ms			

Auxiliary Contact type				Conformity Range		Possible Range		
ID			Default		Min	Max	Min	Max
.099	Contact	Type	n.c. (normally closed)		n.o. (normally opened) n.c. (normally closed)		n.o. (normally opened) n.c. (normally closed) dis. (disabled)	
.100	T Contact	Time OFF	ms	Fixed to 500ms				
.114	I3 STOP	Type	n.o. (normally opened)		n.o. (normally opened) n.c. (normally closed) dis. (disabled)		n.o. (normally opened) n.c. (normally closed) dis. (disabled)	

Turn-on delay				Conformity Range		Possible Range		
ID			Default	Min	Max	Min	Max	
.102	Ton delay	Turn on time	s	60	60	60	0	600

Password					Min	Max
ID				Default		
.106	PW1	1 st digit of Password		0	0	9
.107	PW2	2 nd digit of Password		0	0	9
.108	PW3	3 rd digit of Password		0	0	9
.109	PW4	4 th digit of Password		0	0	9
Remark:		If all 4 digits of the Password are 0 (default setting) the Password request is skipped				

Device Information		
ID		
.105	ID: xxxxxx SW: aa.dd.ccb	xxxxx = Device ID dd: Software version of Display Software aa: Software version of Measuring Software cc: Index of Configuration set b: Version of Configuration set

10.42 OVE E8001/8101:2014 [ID 801] renewed standard

Connection Mode				Conformity Range		Possible Range	
ID	Default						
.003	Connection	4-wire (LN)		4-wire (LN)		2-wire, 3-wire, 4-wire (LN), 4-wire (LN+LL)	

Nominal Voltage				Conformity Range		Possible Range		
ID	Default			Min	Max	Min	Max	
.005	ULN/LL nom	Unom Y	V	230.0	230.0	230.0	28.8	241.4
		Unom Δ	V	400.0	400.0	400.0	50.0	420.0

Functional Safety			Conformity Range		Possible Range		
ID	Default						
.007	Errtol	Fixed to 2ch					
Remark:			2ch means: 2 channel with functional safety and 2 auxilliary contacts necessary				

Overvoltage1 Line to Line				Conformity Range		Possible Range	
ID	Default			Min	Max	Min	Max
.011	ULLmax1off	U _{THR} OFF	%Unom	115	115	100	135
.012	ULLmax1on	U _{THR} ON	%Unom	110	110	100	135
.013	T ULL max1	Time OFF	ms	50	180000	50	180000
Comment:		ULLmax1on has a fixed offset of 0.5% U _{NOM} subtracted from the displayed value					
Only active for:		Connection Modes: 3-wire, 4-wire (LN+LL)					

Undervoltage1 Line to Line				Conformity Range		Possible Range	
ID	Default			Min	Max	Min	Max
.015	ULLmin1off	U _{THR} OFF	%Unom	80	80	10	100
.016	ULLmin1on	U _{THR} ON	%Unom	90	90	10	100
.017	T ULL min1	Time OFF	ms	50	180000	50	180000
Comment:		ULLmin1on has a fixed offset of 0.5% U _{NOM} added to the displayed value					
Only active for:		Connection Modes: 3-wire, 4-wire (LN+LL)					

Overvoltage1 Line to Neutral				Conformity Range		Possible Range	
ID	Default			Min	Max	Min	Max
.019	ULNmax1off	U _{THR} OFF	%Unom	115	115	100	135
.020	ULNmax1on	U _{THR} ON	%Unom	110	110	100	135
.021	T ULN max1	Time OFF	ms	50	180000	50	180000
Comment:		ULNmax1on has a fixed offset of 0.5% U _{NOM} subtracted from the displayed value					
Only active for:		Connection Modes: 2-wire, 4-wire (LN), 4-wire (LN+LL)					

Undervoltage1 Line to Neutral				Conformity Range		Possible Range	
ID	Default			Min	Max	Min	Max
.023	ULNmin1off	U _{THR} OFF	%Unom	80	80	10	100
.024	ULNmin1on	U _{THR} ON	%Unom	90	90	10	100
.025	T ULN min1	Time OFF	ms	50	180000	50	180000
Comment:		ULNmin1on has a fixed offset of 0.5% U _{NOM} added to the displayed value					
Only active for:		Connection Modes: 2-wire, 4-wire (LN), 4-wire (LN+LL)					

Overvoltage2 Line to Line				Conformity Range		Possible Range		
ID				Default	Min	Max	Min	Max
.026	ULL max 2	Enable function		off	on / off		on / off	
.027	ULLmax2off	U _{THR} OFF	%Unom	105	100	135	100	135
.028	ULLmax2on	U _{THR} ON	%Unom	110	110	110	100	135
.029	T ULL max2	Time OFF	ms	60000	50	180000	50	180000
Comment:		ULLmax2on has a fixed offset of 0.5% U _{NOM} subtracted from the displayed value						
Only active for:		Connection Modes: 3-wire, 4-wire (LN+LL)						

Undervoltage2 Line to Line				Conformity Range		Possible Range		
ID				Default	Min	Max	Min	Max
.030	ULL min 2	Enable function		off	on / off		on / off	
.031	ULLmin2off	U _{THR} OFF	%Unom	30	10	100	10	100
.032	ULLmin2on	U _{THR} ON	%Unom	90	90	90	0	100
.033	T ULL min2	Time OFF	ms	50	50	180000	50	180000
Comment:		ULLmin2on has a fixed offset of 0.5% U _{NOM} added to the displayed value						
Only active for:		Connection Modes: 3-wire, 4-wire (LN+LL)						

Overvoltage2 Line to Neutral				Conformity Range		Possible Range		
ID				Default	Min	Max	Min	Max
.034	ULN max 2	Enable function		off	on / off		on / off	
.035	ULNmax2off	U _{THR} OFF	%Unom	105	100	135	100	135
.036	ULNmax2on	U _{THR} ON	%Unom	110	110	110	100	135
.037	T ULN max2	Time OFF	ms	60000	50	180000	50	180000
Comment:		ULNmax2on has a fixed offset of 0.5% U _{NOM} subtracted from the displayed value						
Only active for:		Connection Modes: 2-wire, 4-wire (LN), 4-wire (LN+LL)						

Undervoltage2 Line to Neutral				Conformity Range		Possible Range		
ID				Default	Min	Max	Min	Max
.038	ULN min 2	Enable function		off	on / off		on / off	
.039	ULNmin2off	U _{THR} OFF	%Unom	30	10	100	10	100
.040	ULNmin2on	U _{THR} ON	%Unom	90	90	90	0	100
.041	T ULN min2	Time OFF	ms	50	50	180000	50	180000
Comment:		ULNmin2on has a fixed offset of 0.5% U _{NOM} added to the displayed value						
Only active for:		Connection Modes: 2-wire, 4-wire (LN), 4-wire (LN+LL)						

10 minutes average overvoltage				Conformity Range		Possible Range		
ID				Default	Min	Max	Min	Max
.042	U avg	Enable function		on	on		on / off	
.043	U avg off	U _{THR} OFF	%Unom	112	110	115	100	135
		U _{THR} ON	%Unom	Fixed Hysteresis (0.9% U _{NOM})				
		Time OFF	ms	Fixed to fastest possible disconnection				

Overfrequency1				Conformity Range		Possible Range		
ID				Default	Min	Max	Min	Max
.055	f > off	f _{THR} OFF	Hz	51.50	51.50	51.50	50.00	55.00
		f _{THR} ON	Hz	Fixed reconnection frequency of 50.05Hz				
		Time OFF	ms	Fixed to fastest possible disconnection				

Underfrequency1				Conformity Range		Possible Range		
ID				Default	Min	Max	Min	Max
.059	f < off	f _{THR} OFF	Hz	47.50	47.50	47.50	45.00	50.00
.060	f < on	f _{THR} ON	Hz	47.50	47.50	47.50	45.00	50.00
		Time OFF	ms	Fixed to fastest possible disconnection				
Comment:		f < on has a fixed offset of 0.01 Hz added to the displayed value						

Frequency measuring in general				Conformity Range		Possible Range		
ID				Default	Min	Max	Min	Max
.113	F wnd	Window length	ms	Fixed window length 100ms				

Auxiliary Contact type				Conformity Range		Possible Range		
ID				Default	Min	Max	Min	Max
.099	Contact	Type	n.c. (normally closed)		n.o. (normally opened) n.c. (normally closed)		n.o. (normally opened) n.c. (normally closed) dis. (disabled)	
.100	T Contact	Time OFF	ms	Fixed to 500ms				
.114	I3 STOP	Type	n.o. (normally opened)		n.o. (normally opened) n.c. (normally closed) dis. (disabled)		n.o. (normally opened) n.c. (normally closed) dis. (disabled)	

Turn-on delay				Conformity Range		Possible Range		
ID				Default	Min	Max	Min	Max
.102	Ton delay	Turn on time	s	30	30	30	0	600

Password						
ID				Default	Min	Max
.106	PW1	1 st digit of Password		0	0	9
.107	PW2	2 nd digit of Password		0	0	9
.108	PW3	3 rd digit of Password		0	0	9
.109	PW4	4 th digit of Password		0	0	9
Remark:		If all 4 digits of the Password are 0 (default setting) the Password request is skipped				

Device Information		
ID		
.105	ID: xxxxxx SW: aa.dd.ccb	xxxxx = Device ID dd: Software version of Display Software aa: Software version of Measuring Software cc: Index of Configuration set b: Version of Configuration set

10.43 VDE 0124-100:2013 [ID 300] renewed standard

Connection Mode			Conformity Range		Possible Range	
ID		Default				
.003	Connection	Fixed to 4-wire (LN+LL)				

Nominal Voltage				Conformity Range		Possible Range	
ID		Default		Min	Max	Min	Max
.005	ULN/LL nom	Unom Y	V	Fixed to 230.0 / 400.0			
		Unom Δ	V				

Functional Safety			Conformity Range		Possible Range	
ID		Default				
.007	Errtol	Fixed to 2ch				
Remark:		2ch means: 2 channel with functional safety and 2 auxilliary contacts necessary				

Overvoltage1 Line to Line				Conformity Range		Possible Range	
ID		Default		Min	Max	Min	Max
.011	ULLmax off	U _{THR} OFF	%Unom	115	115	100	135
.012	ULLmax on	U _{THR} ON	%Unom	110	110	100	135
		Time OFF	ms	Fixed to fastest possible disconnection			
Comment:		ULLmax on has a fixed offset of 0.5% U _{NOM} subtracted from the displayed value					

Undervoltage1 Line to Line				Conformity Range		Possible Range	
ID		Default		Min	Max	Min	Max
.015	ULLmin off	U _{THR} OFF	%Unom	80	80	10	100
.016	ULLmin on	U _{THR} ON	%Unom	85	85	10	100
		Time OFF	ms	Fixed to fastest possible disconnection			
Comment:		ULLmin on has a fixed offset of 0.5% U _{NOM} added to the displayed value					

Overvoltage1 Line to Neutral				Conformity Range		Possible Range	
ID		Default		Min	Max	Min	Max
.019	U >> off	U _{THR} OFF	%Unom	115	115	100	135
.020	U >> on	U _{THR} ON	%Unom	110	110	100	135
		Time OFF	ms	Fixed to fastest possible disconnection			
Comment:		U >> on has a fixed offset of 0.5% U _{NOM} subtracted from the displayed value					

Undervoltage1 Line to Neutral				Conformity Range		Possible Range	
ID		Default		Min	Max	Min	Max
.023	U < off	U _{THR} OFF	%Unom	80	80	10	100
.024	U < on	U _{THR} ON	%Unom	85	85	10	100
		Time OFF	ms	Fixed to fastest possible disconnection			
Comment:		U < on has a fixed offset of 0.5% U _{NOM} added to the displayed value					

10 minutes average overvoltage				Conformity Range		Possible Range	
ID		Default		Min	Max	Min	Max
.043	U >	U _{THR} OFF	%Unom	110	110	100	135
		U _{THR} ON	%Unom	Fixed Hysteresis (0.9% U _{NOM})			
		Time OFF	ms	Fixed to fastest possible disconnection			

Overfrequency1				Conformity Range		Possible Range	
ID		Default		Min	Max	Min	Max
.055	f > off	f _{THR} OFF	Hz	51.50	51.50	50.00	55.00
.056	f > on	f _{THR} ON	Hz	50.05	50.05	50.00	55.00
		Time OFF	ms	Fixed to fastest possible disconnection			

Underfrequency1				Conformity Range		Possible Range		
ID				Default	Min	Max	Min	Max
.059	f < off	f _{THR} OFF	Hz	47.50	47.50	47.50	45.00	50.00
.060	f < on	f _{THR} ON	ms	47.50	47.50	47.50	45.00	50.00
		f _{THR} ON	Hz	Fixed reconnection frequency of 50.05Hz				
		Time OFF	ms	Fixed to fastest possible disconnection				
Comment:		f < on has a fixed offset of 0.025 Hz added to the displayed value						

Random overfrequency				Conformity Range		Possible Range		
ID				Default	Min	Max	Min	Max
.086	f > random	Enable function		off	on / off		on / off	
.087	f > random	f _{THR} OFF	Hz		50.20	51.50	50.20	51.50
		f _{THR} ON	Hz	Fixed reconnection frequency of 50.05Hz				
		Time OFF	ms	Fixed to fastest possible disconnection				
Comment:		The random f _{THR} OFF threshold is shown in .087 and cannot be edited						

Frequency measuring in general				Conformity Range		Possible Range		
ID				Default	Min	Max	Min	Max
.113	F wnd	Window length	ms	Fixed window length 100ms				

Auxiliary Contact type				Conformity Range		Possible Range		
ID				Default	Min	Max	Min	Max
.099	Contact	Type	n.c. (normally closed)		n.o. (normally opened) n.c. (normally closed)		n.o. (normally opened) n.c. (normally closed) dis. (disabled)	
.100	T Contact	Time OFF	ms	Fixed to 500ms				
.114	I3 STOP	Type	n.o. (normally opened)		n.o. (normally opened) n.c. (normally closed) dis. (disabled)		n.o. (normally opened) n.c. (normally closed) dis. (disabled)	

Turn-on delay				Conformity Range		Possible Range		
ID				Default	Min	Max	Min	Max
.102	Ton delay	Turn on time	s	60	60	60	0	600

Random Turn-on delay				Conformity Range		Possible Range		
ID				Default	Min	Max	Min	Max
.103	Ton random	Enable function		off	on / off		on / off	
.104	Ton random	Turn on time	s		60	600	60	600
Comment:		The random time value is shown in .104 and cannot be edited						

Password				Default	Min	Max
ID						
.106	PW1	1 st digit of Password		0	0	9
.107	PW2	2 nd digit of Password		0	0	9
.108	PW3	3 rd digit of Password		0	0	9
.109	PW4	4 th digit of Password		0	0	9
Remark:		If all 4 digits of the Password are 0 (default setting) the Password request is skipped				

Device Information		
ID		
.105	ID: xxxxxx SW: aa.dd.ccb	xxxxx = Device ID dd: Software version of Display Software aa: Software version of Measuring Software cc: Index of Configuration set b: Version of Configuration set

10.44 TR3 Rev23:2013 [ID 700] renewed standard

Connection Mode			Conformity Range		Possible Range	
ID		Default				
.003	Connection	4-wire (LN)	3-wire, 4-wire (LN)		2-wire, 3-wire, 4-wire (LN), 4-wire (LN+LL)	

Nominal Voltage				Conformity Range		Possible Range		
ID		Default		Min	Max	Min	Max	
.005	ULN/LL nom	Unom Y	V	230.0	57.5	230.0	28.8	241.4
		Unom Δ	V	400.0	100.0	400.0	50.0	420.0

Functional Safety			Conformity Range		Possible Range	
ID		Default				
.007	Errtol	Fixed to 1ch				
Remark:		1ch means: 1 channel without functional safety and 1 auxilliary contact1 necessary				

Overvoltage1 Line to Line				Conformity Range		Possible Range		
ID		Default		Min	Max	Min	Max	
.011	ULL>> Off	U _{THR} OFF	%Unom	120	100	130	100	135
		U _{THR} ON	%Unom	Fixed Hysteresis (1% U _{NOM})				
.013	T ULL>>	Time OFF	ms	50	50	50	50	10000
Only active for:		Connection Modes: 3-wire, 4-wire (LN+LL)						

Undervoltage1 Line to Line				Conformity Range		Possible Range		
ID		Default		Min	Max	Min	Max	
.015	ULL< Off	U _{THR} OFF	%Unom	80	10	100	10	100
.016	ULL< On	U _{THR} ON	%Unom	95	95	95	10	100
.017	T ULL<	Time OFF	ms	1500	1500	2400	50	10000
Comment:		ULL< On has a fixed offset of 0.5% U _{NOM} added to the displayed value						
Only active for:		Connection Modes: 3-wire, 4-wire (LN+LL)						

Overvoltage1 Line to Neutral				Conformity Range		Possible Range		
ID		Default		Min	Max	Min	Max	
.019	ULN>> Off	U _{THR} OFF	%Unom	120	100	130	100	135
		U _{THR} ON		Fixed Hysteresis (1% U _{NOM})				
.021	T ULN>>	Time OFF	ms	50	50	50	50	10000
Only active for:		Connection Modes: 2-wire, 4-wire (LN), 4-wire (LN+LL)						

Undervoltage1 Line to Neutral				Conformity Range		Possible Range		
ID		Default		Min	Max	Min	Max	
.023	ULN< Off	U _{THR} OFF	%Unom	80	10	100	10	100
.024	ULN< On	U _{THR} ON	%Unom	95	95	95	10	100
.025	T ULN<	Time OFF	ms	1500	1500	2400	50	10000
Comment:		ULN< On has a fixed offset of 0.5% U _{NOM} added to the displayed value						
Only active for:		Connection Modes: 2-wire, 4-wire (LN), 4-wire (LN+LL)						

Undervoltage2 Line to Line				Conformity Range		Possible Range		
ID		Default		Min	Max	Min	Max	
.031	ULL<< Off	U _{THR} OFF	%Unom	45	10	100	0	100
.032	ULL<< On	U _{THR} ON	%Unom	95	95	95	10	100
.033	T ULL<<	Time OFF	ms	300	300	300	50	10000
Comment:		ULL<< On has a fixed offset of 0.5% U _{NOM} added to the displayed value						
Only active for:		Connection Modes: 3-wire, 4-wire (LN+LL)						

Undervoltage2 Line to Neutral				Conformity Range		Possible Range		
ID				Default	Min	Max	Min	Max
.039	ULN<< Off	U _{THR} OFF	%Unom	45	10	100	0	100
.040	ULN<< On	U _{THR} ON	%Unom	95	95	95	10	100
.041	T ULN<<	Time OFF	ms	300	300	300	50	10000
Comment:		ULN<< On has a fixed offset of 0.5% U _{NOM} added to the displayed value						
Only active for:		Connection Modes: 2-wire, 4-wire (LN), 4-wire (LN+LL)						

Overfrequency1				Conformity Range		Possible Range		
ID				Default	Min	Max	Min	Max
.055	f> Off	f _{THR} OFF	Hz	51.50	50.00	52.00	50.00	55.00
.056	f> On	f _{THR} ON	Hz	50.05	50.05	50.05	50.00	55.00
.057	T f>	Time OFF	ms	50	50	50	50	10000

Underfrequency1				Conformity Range		Possible Range		
ID				Default	Min	Max	Min	Max
.059	f< Off	f _{THR} OFF	Hz	47.50	47.50	50.00	45.00	50.00
.060	f< On	f _{THR} ON	Hz	47.50	47.50	47.50	45.00	50.00
.061	T f<	Time OFF	ms	50	50	50	50	10000
Comment:		f< On has a fixed offset of 0.025 Hz added to the displayed value						

Frequency measuring in general				Conformity Range		Possible Range		
ID				Default	Min	Max	Min	Max
.113	F wnd	Window length	ms	Fixed window length 100ms				

Auxiliary Contact type				Conformity Range		Possible Range		
ID				Default	Min	Max	Min	Max
.099	Contact	Type	dis. (disabled)		n.o. (normally opened) n.c. (normally closed) dis. (disabled)		n.o. (normally opened) n.c. (normally closed) dis. (disabled)	
.100	T Contact	Time OFF	ms	Fixed to 500ms				
.114	I3 STOP	Type	n.o. (normally opened)		n.o. (normally opened) n.c. (normally closed) dis. (disabled)		n.o. (normally opened) n.c. (normally closed) dis. (disabled)	

Turn-on delay				Conformity Range		Possible Range		
ID				Default	Min	Max	Min	Max
.102	Ton delay	Turn on time	s	60	0	60	0	600

Password				Default	Min	Max
ID						
.106	PW1	1 st digit of Password		0	0	9
.107	PW2	2 nd digit of Password		0	0	9
.108	PW3	3 rd digit of Password		0	0	9
.109	PW4	4 th digit of Password		0	0	9
Remark:		If all 4 digits of the Password are 0 (default setting) the Password request is skipped				

Device Information		
ID		
.105	ID: xxxxxx SW: aa.dd.ccb	xxxxx = Device ID dd: Software version of Display Software aa: Software version of Measuring Software cc: Index of Configuration set b: Version of Configuration set

10.45 AS/NZS 4777.2:2015 [ID 1102] renewed standard

Connection Mode				Conformity Range		Possible Range	
ID		Default					
.003	Connection	4-wire (LN)		4-wire (LN)		2-wire, 3-wire, 4-wire (LN), 4-wire (LN+LL)	

Nominal Voltage				Conformity Range		Possible Range		
ID		Default		Min	Max	Min	Max	
.005	ULN/LL nom	Unom Y	V	230.0	230.0	240.0	100.0	240.0
		Unom Δ	V	400.0	400.0	417.4	173.9	417.4

Functional Safety				Conformity Range		Possible Range	
ID		Default					
.007	Errtol	Fixed to 2ch					
Remark:		2ch means: 2 channel with functional safety and 2 auxilliary contacts necessary					

Overvoltage1 Line to Neutral				Conformity Range		Possible Range	
ID		Default		Min	Max	Min	Max
.019	V> off	U _{THR} OFF	%Unom	113	113	100	135
.020	V> on	U _{THR} ON	%Unom	111	112	100	135
.021	T V>	Time OFF	ms	2000	2000	100	300000

Undervoltage1 Line to Neutral				Conformity Range		Possible Range	
ID		Default		Min	Max	Min	Max
.023	V< off	U _{THR} OFF	%Unom	78	78	0	100
.024	V< on	U _{THR} ON	%Unom	80	100	0	100
.025	T V<	Time OFF	ms	2000	2000	100	300000

Overvoltage2 Line to Neutral				Conformity Range		Possible Range	
ID		Default		Min	Max	Min	Max
.034	V>>	Enable function		off	on / off	on / off	
.035	V>> off	U _{THR} OFF	%Unom	115	115	100	135
.036	V>> on	U _{THR} ON	%Unom	111	112	100	135
.037	T V>>	Time OFF	ms	200	200	100	300000

10 minutes average overvoltage				Conformity Range		Possible Range	
ID		Default		Min	Max	Min	Max
.042	Uavg	Enable function		on	on / off	on / off	
.043	Uavg off	U _{THR} OFF	%Unom	112	112	100	135
.044	Uavg on	U _{THR} ON	%Unom	111	111	100	135
		Time OFF	ms	Fixed to fastest possible disconnection			

Overfrequency1				Conformity Range		Possible Range	
ID		Default		Min	Max	Min	Max
.055	F> off	f _{THR} OFF	Hz	52.00	52.00	50.00	55.00
.056	F> on	f _{THR} ON	Hz	51.90	51.90	50.00	55.00
.057	T F>	Time OFF	ms	2000	2000	100	300000

Underfrequency1				Conformity Range		Possible Range	
ID		Default		Min	Max	Min	Max
.059	F< off	f _{THR} OFF	Hz	47.00	47.00	40.00	50.00
.060	F< on	f _{THR} ON	Hz	47.50	50.00	40.00	50.00
.061	T F<	Time OFF	ms	2000	2000	1000	300000

Frequency measuring in general				Conformity Range		Possible Range		
ID				Default	Min	Max	Min	Max
.113	F wnd	Window length	ms	Fixed window length 100ms				

Rate of Change of Frequency (RoCoF)				Conformity Range		Possible Range		
ID				Default	Min	Max	Min	Max
.090	RoCoF	Enable Function		on	on / off		on / off	
.091	RoCoF off	RoCoF _{THR} OFF	mHz/s	1000	10	3000	10	3000
.092	RoCoF on	RoCoF _{THR} ON	mHz/s	950	10	3000	10	3000
.093	RoCoFDelay	Time OFF	ms	500	50	500	50	10000
.111	RoCoF wnd	Window length	ms	225	100	1000	100	1000

Phase Shift (PShift)				Conformity Range		Possible Range		
ID				Default	Min	Max	Min	Max
.094	PShift	Enable Function		on	on / off		on / off	
.095	PShift off	PShift _{THR} OFF	°	8	1	8	1	15
.096	PShift on	PShift _{THR} ON	°	6	1	7	1	15
.097	PShiftDel	Time OFF	ms	50	50	50	50	10000
.112	PShift wnd	Window length	ms	50	50	500	50	1000

Auxiliary Contact type				Conformity Range		Possible Range		
ID				Default	Min	Max	Min	Max
.099	Contact	Type	dis. (disabled)		n.o. (normally opened) n.c. (normally closed) dis. (disabled)		n.o. (normally opened) n.c. (normally closed) dis. (disabled)	
.100	T Contact	Time OFF	ms	Fixed to 500ms				
.114	I3 STOP	Type	n.o. (normally opened)		n.o. (normally opened) n.c. (normally closed) dis. (disabled)		n.o. (normally opened) n.c. (normally closed) dis. (disabled)	

Turn-on delay				Conformity Range		Possible Range		
ID				Default	Min	Max	Min	Max
.102	Ton delay	Turn on time	s	60	0	60	0	600

Password				Default	Min	Max
ID						
.106	PW1	1 st digit of Password		0	0	9
.107	PW2	2 nd digit of Password		0	0	9
.108	PW3	3 rd digit of Password		0	0	9
.109	PW4	4 th digit of Password		0	0	9
Remark:		If all 4 digits of the Password are 0 (default setting) the Password request is skipped				

Device Information		
ID		
.105	ID: xxxxxx	xxxxx = Device ID
	SW: aa.dd.ccb	dd: Software version of Display Software aa: Software version of Measuring Software cc: Index of Configuration set b: Version of Configuration set

10.46 G59/3/3:2015 LV [ID 405] renewed standard

Connection Mode			Conformity Range		Possible Range	
ID		Default				
.003	Connection	Fixed to 4-wire (LN)				

Nominal Voltage				Conformity Range		Possible Range		
ID			Default	Min	Max	Min	Max	
.005	ULN/LL nom	Unom Y	V	230.0	230.0	240.0	100.0	240.0
		Unom Δ	V	400.0	400.0	417.4	173.9	417.4

Functional Safety			Conformity Range		Possible Range	
ID		Default				
.007	Errtol	Fixed to 1ch				
Remark:		1ch means: 1 channel without functional safety and 1 auxilliary contact1 necessary				

Overvoltage1 Line to Neutral				Conformity Range		Possible Range		
ID			Default	Min	Max	Min	Max	
.019	O/V st 1	U _{THR} OFF	%Unom	114	114	114	100	135
		U _{THR} ON	%Unom	Fixed Hysteresis (0.75% U _{NOM})				
.021	T O/V st 1	Time OFF	ms	1000	1000	1000	50	300000

Undervoltage1 Line to Neutral				Conformity Range		Possible Range		
ID			Default	Min	Max	Min	Max	
.023	U/V st 1	U _{THR} OFF	%Unom	87	87	87	0	100
		U _{THR} ON	%Unom	Fixed Hysteresis (0.75% U _{NOM})				
.025	T U/V st 1	Time OFF	ms	2500	2500	2500	50	300000

Overvoltage2 Line to Neutral				Conformity Range		Possible Range		
ID			Default	Min	Max	Min	Max	
.035	O/V st 2	U _{THR} OFF	%Unom	119	119	119	100	135
		U _{THR} ON	%Unom	Fixed Hysteresis (0.75% U _{NOM})				
.037	T O/V st 2	Time OFF	ms	500	500	500	50	300000

Undervoltage2 Line to Neutral				Conformity Range		Possible Range		
ID			Default	Min	Max	Min	Max	
.039	U/V st 2	U _{THR} OFF	%Unom	80	80	80	0	100
		U _{THR} ON	%Unom	Fixed Hysteresis (0.75% U _{NOM})				
.041	T U/V st 2	Time OFF	ms	500	500	500	50	300000

Overfrequency1				Conformity Range		Possible Range		
ID			Default	Min	Max	Min	Max	
.055	O/F st 1	f _{THR} OFF	Hz	51.50	51.50	51.50	50.00	55.00
		f _{THR} ON	Hz	Fixed Hysteresis (0.05 Hz)				
.057	T O/F st 1	Time OFF	ms	90000	90000	90000	1000	300000

Underfrequency1				Conformity Range		Possible Range		
ID			Default	Min	Max	Min	Max	
.059	U/F st 1	f _{THR} OFF	Hz	47.50	47.50	47.50	40.00	50.00
		f _{THR} ON	Hz	Fixed Hysteresis (0.05 Hz)				
.061	T U/F st 1	Time OFF	ms	20000	20000	20000	1000	300000

Overfrequency2				Conformity Range		Possible Range		
ID				Default	Min	Max	Min	Max
.063	O/F st 2	f _{THR} OFF	Hz	52.00	52.00	52.00	50.00	55.00
		f _{THR} ON	Hz	Fixed Hysteresis (0.05 Hz)				
.065	T O/F st 2	Time OFF	ms	500	500	500	50	300000

Underfrequency2				Conformity Range		Possible Range		
ID				Default	Min	Max	Min	Max
.067	U/F st 2	f _{THR} OFF	Hz	47.00	47.00	47.00	40.00	50.00
		f _{THR} ON	Hz	Fixed Hysteresis (0.05 Hz)				
.069	T U/F st 2	Time OFF	ms	500	500	500	50	300000

Frequency measuring in general				Conformity Range		Possible Range		
ID				Default	Min	Max	Min	Max
.113	F wnd	Window length	ms	Fixed window length 100ms				

Rate of Change of Frequency (RoCoF)				Conformity Range		Possible Range		
ID				Default	Min	Max	Min	Max
.090	RoCoF	Enable Function		on	on / off		on / off	
.091	RoCoF off	RoCoF _{THR} OFF	mHz/s	1000	10	3000	10	3000
.092	RoCoF on	RoCoF _{THR} ON	mHz/s	950	10	3000	10	3000
.093	RoCoFDelay	Time OFF	ms	500	50	2000	50	2000
.111	RoCoF wnd	Window length	ms	Fixed window length 225ms				

Phase Shift (PShift)				Conformity Range		Possible Range		
ID				Default	Min	Max	Min	Max
.094	PShift	Enable Function		off	on / off		on / off	
.095	PShift off	PShift _{THR} OFF	°	12	6	12	3	15
.096	PShift on	PShift _{THR} ON	°	9	5	11	3	15
		Time OFF	ms	Fixed to the fastest possible disconnection				
.112	PShift wnd	Window length	ms	Fixed window length 200ms				

Auxiliary Contact type				Conformity Range		Possible Range		
ID				Default	Min	Max	Min	Max
.099	Contact	Type		dis. (disabled)	n.o. (normally opened) n.c. (normally closed) dis. (disabled)		n.o. (normally opened) n.c. (normally closed) dis. (disabled)	
.100	T Contact	Time OFF	ms	Fixed to 500ms				
.114	I3 STOP	Type		n.o. (normally opened)	n.o. (normally opened) n.c. (normally closed) dis. (disabled)		n.o. (normally opened) n.c. (normally closed) dis. (disabled)	

Turn-on delay				Conformity Range		Possible Range		
ID				Default	Min	Max	Min	Max
.102	Ton delay	Turn on time	s	20	20	20	0	600

Password				Default	Min	Max
ID						
.106	PW1	1 st digit of Password		0	0	9
.107	PW2	2 nd digit of Password		0	0	9
.108	PW3	3 rd digit of Password		0	0	9
.109	PW4	4 th digit of Password		0	0	9
Remark:		If all 4 digits of the Password are 0 (default setting) the Password request is skipped				

Device Information		
ID		
.105	ID: xxxxxx SW: aa.dd.ccb	xxxxx = Device ID dd: Software version of Display Software aa: Software version of Measuring Software cc: Index of Configuration set b: Version of Configuration set

10.47 G59/3/3:2015 MV [ID 455] renewed standard

Connection Mode			Conformity Range		Possible Range	
ID		Default				
.003	Connection	Fixed to 3-wire				

Nominal Voltage				Conformity Range		Possible Range		
ID			Default	Min	Max	Min	Max	
.005	ULN/LL nom	Unom Y	V	230.0	57.5	230.0	28.8	241.4
		Unom Δ	V	400.0	100.0	400.0	50.0	420.0

Functional Safety			Conformity Range		Possible Range	
ID		Default				
.007	Errtol	Fixed to 1ch				
Remark:		1ch means: 1 channel without functional safety and 1 auxilliary contact1 necessary				

Overvoltage1 Line to Line				Conformity Range		Possible Range		
ID			Default	Min	Max	Min	Max	
.011	O/V st 1	U _{THR} OFF	%Unom	110	110	110	100	135
		U _{THR} ON	%Unom	Fixed Hysteresis (0.75% U _{NOM})				
.013	T O/V st 1	Time OFF	ms	1000	1000	1000	50	300000

Undervoltage1 Line to Line				Conformity Range		Possible Range		
ID			Default	Min	Max	Min	Max	
.015	U/V st 1	U _{THR} OFF	%Unom	87	87	87	0	100
		U _{THR} ON	%Unom	Fixed Hysteresis (0.75% U _{NOM})				
.017	T U/V st 1	Time OFF	ms	2500	2500	2500	50	300000

Overvoltage2 Line to Line				Conformity Range		Possible Range		
ID			Default	Min	Max	Min	Max	
.027	O/V st 2	U _{THR} OFF	%Unom	113	113	113	100	135
		U _{THR} ON	%Unom	Fixed Hysteresis (0.75% U _{NOM})				
.029	T O/V st 2	Time OFF	ms	500	500	500	50	300000

Undervoltage2 Line to Line				Conformity Range		Possible Range		
ID			Default	Min	Max	Min	Max	
.031	U/V st 2	U _{THR} OFF	%Unom	80	80	80	0	100
		U _{THR} ON	%Unom	Fixed Hysteresis (0.75% U _{NOM})				
.033	T U/V st 2	Time OFF	ms	500	500	500	50	300000

Overfrequency1				Conformity Range		Possible Range		
ID			Default	Min	Max	Min	Max	
.055	O/F st 1	f _{THR} OFF	Hz	51.50	51.50	51.50	50.00	55.00
		f _{THR} ON	Hz	Fixed Hysteresis (0.05 Hz)				
.057	T O/F st 1	Time OFF	ms	90000	90000	90000	1000	300000

Underfrequency1				Conformity Range		Possible Range		
ID			Default	Min	Max	Min	Max	
.059	U/F st 1	f _{THR} OFF	Hz	47.50	47.50	47.50	40.00	50.00
		f _{THR} ON	Hz	Fixed Hysteresis (0.05 Hz)				
.061	T U/F st 1	Time OFF	ms	20000	20000	20000	1000	300000

Overfrequency2				Conformity Range		Possible Range		
ID				Default	Min	Max	Min	Max
.063	O/F st 2	f _{THR} OFF	Hz	52.00	52.00	52.00	50.00	55.00
		f _{THR} ON	Hz	Fixed Hysteresis (0.05 Hz)				
.065	T O/F st 2	Time OFF	ms	500	500	500	50	300000

Underfrequency2				Conformity Range		Possible Range		
ID				Default	Min	Max	Min	Max
.067	U/F st 2	f _{THR} OFF	Hz	47.00	47.00	47.00	40.00	50.00
		f _{THR} ON	Hz	Fixed Hysteresis (0.05 Hz)				
.069	T U/F st 2	Time OFF	ms	500	500	500	50	300000

Frequency measuring in general				Conformity Range		Possible Range		
ID				Default	Min	Max	Min	Max
.113	F wnd	Window length	ms	Fixed window length 100ms				

Rate of Change of Frequency (RoCoF)				Conformity Range		Possible Range		
ID				Default	Min	Max	Min	Max
.090	RoCoF	Enable Function		on	on / off		on / off	
.091	RoCoF off	RoCoF _{THR} OFF	mHz/s	1000	10	3000	10	3000
.092	RoCoF on	RoCoF _{THR} ON	mHz/s	950	10	3000	10	3000
.093	RoCoFDelay	Time OFF	ms	500	50	2000	50	2000
.111	RoCoF wnd	Window length	ms	Fixed window length 225ms				

Phase Shift (PShift)				Conformity Range		Possible Range		
ID				Default	Min	Max	Min	Max
.094	PShift	Enable Function		off	on / off		on / off	
.095	PShift off	PShift _{THR} OFF	°	12	6	12	3	15
.096	PShift on	PShift _{THR} ON	°	9	5	11	3	15
		Time OFF	ms	Fixed to the fastest possible disconnection				
.112	PShift wnd	Window length	ms	Fixed window length 200ms				
Comment:		PShift off has a fixed offset of 0.2° subtracted from the displayed value						

Auxiliary Contact type				Conformity Range		Possible Range		
ID				Default	Min	Max	Min	Max
.099	Contact	Type		dis. (disabled)	n.o. (normally opened) n.c. (normally closed) dis. (disabled)		n.o. (normally opened) n.c. (normally closed) dis. (disabled)	
.100	T Contact	Time OFF	ms	Fixed to 500ms				
.114	I3 STOP	Type		n.o. (normally opened)	n.o. (normally opened) n.c. (normally closed) dis. (disabled)		n.o. (normally opened) n.c. (normally closed) dis. (disabled)	

Turn-on delay				Conformity Range		Possible Range		
ID				Default	Min	Max	Min	Max
.102	Ton delay	Turn on time	s	20	20	20	0	600

Password				Default	Min	Max
ID						
.106	PW1	1 st digit of Password		0	0	9
.107	PW2	2 nd digit of Password		0	0	9
.108	PW3	3 rd digit of Password		0	0	9
.109	PW4	4 th digit of Password		0	0	9
Remark:		If all 4 digits of the Password are 0 (default setting) the Password request is skipped				

Device Information		
ID		
.105	ID: xxxxxx SW: aa.dd.ccb	xxxxx = Device ID dd: Software version of Display Software aa: Software version of Measuring Software cc: Index of Configuration set b: Version of Configuration set

10.48 G83/2:2012 [ID 500] renewed standard

Connection Mode			Conformity Range		Possible Range	
ID	Default					
.003	Connection	Fixed to 4-wire (LN)				

Nominal Voltage				Conformity Range		Possible Range		
ID	Default			Min	Max	Min	Max	
.005	ULN/LL nom	Unom Y	V	230.0	230.0	240.0	100.0	240.0
		Unom Δ	V	400.0	400.0	417.4	173.9	417.4

Functional Safety			Conformity Range		Possible Range	
ID	Default					
.007	Errtol	Fixed to 1ch				
Remark:		1ch means: 1 channel without functional safety and 1 auxilliary contact1 necessary				

Overvoltage1 Line to Neutral				Conformity Range		Possible Range		
ID	Default			Min	Max	Min	Max	
.019	O/V st 1	U _{THR} OFF	%Unom	114	114	114	100	135
		U _{THR} ON	%Unom	Fixed Hysteresis (0.75% U _{NOM})				
.021	T O/V st 1	Time OFF	ms	1000	1000	1000	50	10000

Undervoltage1 Line to Neutral				Conformity Range		Possible Range		
ID	Default			Min	Max	Min	Max	
.023	U/V st 1	U _{THR} OFF	%Unom	87	87	87	0	100
		U _{THR} ON	%Unom	Fixed Hysteresis (0.75% U _{NOM})				
.025	T U/V st 1	Time OFF	ms	2500	2500	2500	50	10000

Overvoltage2 Line to Neutral				Conformity Range		Possible Range		
ID	Default			Min	Max	Min	Max	
.035	O/V st 2	U _{THR} OFF	%Unom	119	119	119	100	135
		U _{THR} ON	%Unom	Fixed Hysteresis (0.75% U _{NOM})				
.037	T O/V st 2	Time OFF	ms	500	500	500	50	10000

Undervoltage2 Line to Neutral				Conformity Range		Possible Range		
ID	Default			Min	Max	Min	Max	
.039	U/V st 2	U _{THR} OFF	%Unom	80	80	80	0	100
		U _{THR} ON	%Unom	Fixed Hysteresis (0.75% U _{NOM})				
.041	T U/V st 2	Time OFF	ms	500	500	500	50	10000

Overfrequency1				Conformity Range		Possible Range		
ID	Default			Min	Max	Min	Max	
.055	O/F st 1	f _{THR} OFF	Hz	51.50	51.50	51.50	50.00	55.00
		f _{THR} ON	Hz	Fixed Hysteresis (0.05 Hz)				
.057	T O/F st 1	Time OFF	ms	90000	90000	90000	1000	120000

Underfrequency1				Conformity Range		Possible Range		
ID	Default			Min	Max	Min	Max	
.059	U/F st 1	f _{THR} OFF	Hz	47.50	47.50	47.50	40.00	50.00
		f _{THR} ON	Hz	Fixed Hysteresis (0.05 Hz)				
.061	T U/F st 1	Time OFF	ms	20000	20000	20000	1000	120000

Overfrequency2				Conformity Range		Possible Range		
ID				Default	Min	Max	Min	Max
.063	O/F st 2	f _{THR} OFF	Hz	52.00	52.00	52.00	50.00	55.00
		f _{THR} ON	Hz	Fixed Hysteresis (0.05 Hz)				
.065	T O/F st 2	Time OFF	ms	500	500	500	50	10000

Underfrequency2				Conformity Range		Possible Range		
ID				Default	Min	Max	Min	Max
.067	U/F st 2	f _{THR} OFF	Hz	47.00	47.00	47.00	40.00	50.00
		f _{THR} ON	Hz	Fixed Hysteresis (0.05 Hz)				
.069	T U/F st 2	Time OFF	ms	500	500	500	50	10000

Frequency measuring in general				Conformity Range		Possible Range		
ID				Default	Min	Max	Min	Max
.113	F wnd	Window length	ms	Fixed window length 100ms				

Rate of Change of Frequency (RoCoF)				Conformity Range		Possible Range		
ID				Default	Min	Max	Min	Max
.090	RoCoF	Enable Function		off	on / off		on / off	
.091	RoCoF off	RoCoF _{THR} OFF	mHz/s	200	190	210	100	1000
.092	RoCoF on	RoCoF _{THR} ON	mHz/s	190	180	210	100	1000
		Time OFF	ms	Fixed to the fastest possible disconnection				
.111	RoCoF wnd	Window length	ms	Fixed window length 535ms				

Phase Shift (PShift)				Conformity Range		Possible Range		
ID				Default	Min	Max	Min	Max
.094	PShift	Enable Function		on	on / off		on / off	
.095	PShift off	PShift _{THR} OFF	°	12.0	11.0	13.0	3.0	15.0
.096	PShift on	PShift _{THR} ON	°	10.5	9.5	13.0	3.0	15.0
		Time OFF	ms	Fixed to the fastest possible disconnection				
.112	PShift wnd	Window length	ms	Fixed window length 200ms				

Auxiliary Contact type				Conformity Range		Possible Range		
ID				Default	Min	Max	Min	Max
.099	Contact	Type	dis. (disabled)		n.o. (normally opened) n.c. (normally closed) dis. (disabled)		n.o. (normally opened) n.c. (normally closed) dis. (disabled)	
.100	T Contact	Time OFF	ms	Fixed to 500ms				
.114	I3 STOP	Type	n.o. (normally opened)		n.o. (normally opened) n.c. (normally closed) dis. (disabled)		n.o. (normally opened) n.c. (normally closed) dis. (disabled)	

Turn-on delay				Conformity Range		Possible Range		
ID				Default	Min	Max	Min	Max
.102	Ton delay	Turn on time	s	20	20	20	0	600

Password						
ID				Default	Min	Max
.106	PW1	1 st digit of Password		0	0	9
.107	PW2	2 nd digit of Password		0	0	9
.108	PW3	3 rd digit of Password		0	0	9
.109	PW4	4 th digit of Password		0	0	9
Remark:	If all 4 digits of the Password are 0 (default setting) the Password request is skipped					

Device Information		
ID		
.105	ID: xxxxxx SW: aa.dd.ccb	xxxxx = Device ID dd: Software version of Display Software aa: Software version of Measuring Software cc: Index of Configuration set b: Version of Configuration set

10.49 C10-11:2013 LV [ID 600] renewed standard

Connection Mode			Conformity Range		Possible Range	
ID		Default				
.003	Connection	4-wire (LN)	2-wire, 3-wire, 4-wire (LN), 4-wire (LN+LL)		2-wire, 3-wire, 4-wire (LN), 4-wire (LN+LL)	

Nominal Voltage				Conformity Range		Possible Range	
ID		Default		Min	Max	Min	Max
.005	ULN/LL nom	Unom Y	V	230.0	230.0	100.0	240.0
		Unom Δ	V	400.0	400.0	173.9	417.4

Functional Safety			Conformity Range		Possible Range	
ID		Default				
.007	Errtol	Fixed to 1ch				
Remark:		1ch means: 1 channel without functional safety and 1 auxilliary contact1 necessary				

Overvoltage1 Line to Neutral				Conformity Range		Possible Range	
ID		Default		Min	Max	Min	Max
.019	U LN >	U _{THR} OFF	%Unom	110	100	110	135
		U _{THR} ON	%Unom	Fixed Hysteresis (0.5% U _{NOM})			
		Time OFF	ms	Fixed to fastest possible disconnection			
Comment:		U LN > has a fixed offset of 0.25% U _{NOM} subtracted from the displayed value					
Only active for:		Connection Modes: 2-wire, 4-wire (LN), 4-wire (LN+LL)					

Undervoltage1 Line to Neutral				Conformity Range		Possible Range	
ID		Default		Min	Max	Min	Max
.023	U LN <	U _{THR} OFF	%Unom	85	50	85	100
		U _{THR} ON	%Unom	Fixed Hysteresis (0.5% U _{NOM})			
		Time OFF	ms	1500	100	1500	10000
Comment:		U LN < has a fixed offset of 0.25% U _{NOM} added to the displayed value					
Only active for:		Connection Modes: 2-wire, 4-wire (LN), 4-wire (LN+LL)					

Undervoltage2 Line to Neutral				Conformity Range		Possible Range	
ID		Default		Min	Max	Min	Max
.039	U LN <<	U _{THR} OFF	%Unom	50	25	50	100
		U _{THR} ON	%Unom	Fixed Hysteresis (0.5% U _{NOM})			
		Time OFF	ms	Fixed to fastest possible disconnection			
Comment:		U LN << has a fixed offset of 0.25% U _{NOM} added to the displayed value					
Only active for:		Connection Modes: 2-wire, 4-wire (LN), 4-wire (LN+LL)					

Overfrequency1				Conformity Range		Possible Range	
ID		Default		Min	Max	Min	Max
.055	f >	f _{THR} OFF	Hz	51.50	50.00	51.50	55.00
		f _{THR} ON	Hz	Fixed reconnection frequency of 50.05Hz			
		Time OFF	ms	Fixed to fastest possible disconnection			
Comment:		f > has a fixed offset of 0.01 Hz subtracted from the displayed value					

Underfrequency1				Conformity Range		Possible Range	
ID		Default		Min	Max	Min	Max
.059	f < off	f _{THR} OFF	Hz	47.50	47.50	40.00	50.00
.060	f < on	f _{THR} ON	Hz	47.50	47.50	40.00	50.00
		Time OFF	ms	Fixed to fastest possible disconnection			
Comment:		f < on has a fixed offset of 0.02 Hz added to the displayed value					

Frequency measuring in general				Conformity Range		Possible Range		
ID				Default	Min	Max	Min	Max
.113	F wnd	Window length	ms	Fixed window length 100ms				

Rate of Change of Frequency (RoCoF)				Conformity Range		Possible Range		
ID				Default	Min	Max	Min	Max
.090	RoCoF	Enable Function		off	on / off		on / off	
.091	RoCoF off	RoCoF _{THR} OFF	mHz/s	1000	1000	1000	100	2000
.092	RoCoF on	RoCoF _{THR} ON	mHz/s	800	100	1000	100	1000
.093	RoCoF T	Time OFF	ms	0	0	100	0	1000
.111	RoCoF wnd	Window length	ms	Fixed window length 100ms				

Phase Shift (PShift)				Conformity Range		Possible Range		
ID				Default	Min	Max	Min	Max
.094	PShift	Enable Function		on	on / off		on / off	
.095	PShift off	PShift _{THR} OFF	°	7	7	7	3	15
.096	PShift on	PShift _{THR} ON	°	5	3	7	3	15
		Time OFF	ms	Fixed to the fastest possible disconnection				
.112	PShift wnd	Window length	ms	Fixed window length 100ms				
Comment:		PShift off has a fixed offset of 1° subtracted from the displayed value						

Auxiliary Contact type				Conformity Range		Possible Range		
ID				Default	Min	Max	Min	Max
.099	Contact	Type	dis. (disabled)		n.o. (normally opened) n.c. (normally closed) dis. (disabled)		n.o. (normally opened) n.c. (normally closed) dis. (disabled)	
.100	T Contact	Time OFF	ms	Fixed to 500ms				
.114	I3 STOP	Type	n.o. (normally opened)		n.o. (normally opened) n.c. (normally closed) dis. (disabled)		n.o. (normally opened) n.c. (normally closed) dis. (disabled)	

Turn-on delay				Conformity Range		Possible Range		
ID				Default	Min	Max	Min	Max
.102	Ton delay	Turn on time	s	60	60	60	0	600

Password				Default	Min	Max
ID						
.106	PW1	1 st digit of Password		0	0	9
.107	PW2	2 nd digit of Password		0	0	9
.108	PW3	3 rd digit of Password		0	0	9
.109	PW4	4 th digit of Password		0	0	9
Remark:		If all 4 digits of the Password are 0 (default setting) the Password request is skipped				

Device Information		
ID		
.105	ID: xxxxxx	xxxxx = Device ID
	SW: aa.dd.ccb	dd: Software version of Display Software aa: Software version of Measuring Software cc: Index of Configuration set b: Version of Configuration set

10.50 C10-11:2013 MV [ID 650] renewed standard

Connection Mode			Conformity Range		Possible Range	
ID		Default				
.003	Connection	3-wire	3-wire		2-wire, 3-wire, 4-wire (LN), 4-wire (LN+LL)	

Nominal Voltage				Conformity Range		Possible Range	
ID		Default		Min	Max	Min	Max
.005	ULN/LL nom	Unom Y	V	230.0	230.0	28.8	241.4
		Unom Δ	V	400.0	400.0	50.0	420.0

Functional Safety			Conformity Range		Possible Range	
ID		Default				
.007	Errtol	Fixed to 1ch				
Remark:		1ch means: 1 channel without functional safety and 1 auxilliary contact1 necessary				

Overvoltage1 Line to Line				Conformity Range		Possible Range	
ID		Default		Min	Max	Min	Max
.011	U LL >	U _{THR} OFF	%Unom	110	100	100	135
		U _{THR} ON	%Unom	Fixed Hysteresis (0.5% U _{NOM})			
		Time OFF	ms	Fixed to fastest possible disconnection			
Comment:		U LL > has a fixed offset of 0.25% U _{NOM} subtracted from the displayed value					
Only active for:		Connection Modes: 3-wire, 4-wire (LN+LL)					

Undervoltage1 Line to Line				Conformity Range		Possible Range	
ID		Default		Min	Max	Min	Max
.015	U LL <	U _{THR} OFF	%Unom	85	50	0	100
		U _{THR} ON	%Unom	Fixed Hysteresis (0.5% U _{NOM})			
		Time OFF	ms	1500	100	1500	100
Comment:		U LL < has a fixed offset of 0.25% U _{NOM} added to the displayed value					
Only active for:		Connection Modes: 3-wire, 4-wire (LN+LL)					

Undervoltage2 Line to Line				Conformity Range		Possible Range	
ID		Default		Min	Max	Min	Max
.031	U LL <<	U _{THR} OFF	%Unom	50	25	0	100
		U _{THR} ON	%Unom	Fixed Hysteresis (0.5% U _{NOM})			
		Time OFF	ms	Fixed to fastest possible disconnection			
Comment:		U LL << has a fixed offset of 0.25% U _{NOM} added to the displayed value					
Only active for:		Connection Modes: 3-wire, 4-wire (LN+LL)					

Overfrequency1				Conformity Range		Possible Range	
ID		Default		Min	Max	Min	Max
.055	f >	f _{THR} OFF	Hz	51.50	50.00	50.00	55.00
		f _{THR} ON	Hz	Fixed reconnection frequency of 50.05Hz			
		Time OFF	ms	Fixed to fastest possible disconnection			
Comment:		f > has a fixed offset of 0.01 Hz subtracted from the displayed value					

Underfrequency1				Conformity Range		Possible Range	
ID		Default		Min	Max	Min	Max
.059	f < off	f _{THR} OFF	Hz	47.50	47.50	40.00	50.00
.060	f < on	f _{THR} ON	Hz	47.50	47.50	40.00	50.00
		Time OFF	ms	Fixed to fastest possible disconnection			
Comment:		f < on has a fixed offset of 0.02 Hz added to the displayed value					

Frequency measuring in general				Conformity Range		Possible Range		
ID				Default	Min	Max	Min	Max
.113	F wnd	Window length	ms	Fixed window length 100ms				

Rate of Change of Frequency (RoCoF)				Conformity Range		Possible Range		
ID				Default	Min	Max	Min	Max
.090	RoCoF	Enable Function		off	on / off		on / off	
.091	RoCoF off	RoCoF _{THR} OFF	mHz/s	1000	1000	1000	100	2000
.092	RoCoF on	RoCoF _{THR} ON	mHz/s	800	100	1000	100	1000
.093	RoCoF T	Time OFF	ms	0	0	100	0	1000
.111	RoCoF wnd	Window length	ms	Fixed window length 100ms				

Phase Shift (PShift)				Conformity Range		Possible Range		
ID				Default	Min	Max	Min	Max
.094	PShift	Enable Function		on	on / off		on / off	
.095	PShift off	PShift _{THR} OFF	°	7	7	7	3	15
.096	PShift on	PShift _{THR} ON	°	5	3	7	3	15
		Time OFF	ms	Fixed to the fastest possible disconnection				
.112	PShift wnd	Window length	ms	Fixed window length 100ms				
Comment:		PShift off has a fixed offset of 1° subtracted from the displayed value						

Auxiliary Contact type				Conformity Range		Possible Range		
ID				Default	Min	Max	Min	Max
.099	Contact	Type		dis. (disabled)	n.o. (normally opened) n.c. (normally closed) dis. (disabled)		n.o. (normally opened) n.c. (normally closed) dis. (disabled)	
.100	T Contact	Time OFF	ms	Fixed to 270ms				
.114	I3 STOP	Type		n.o. (normally opened)	n.o. (normally opened) n.c. (normally closed) dis. (disabled)		n.o. (normally opened) n.c. (normally closed) dis. (disabled)	

Turn-on delay				Conformity Range		Possible Range		
ID				Default	Min	Max	Min	Max
.102	Ton delay	Turn on time	s	60	60	60	0	600

Password				Default	Min	Max
ID						
.106	PW1	1 st digit of Password		0	0	9
.107	PW2	2 nd digit of Password		0	0	9
.108	PW3	3 rd digit of Password		0	0	9
.109	PW4	4 th digit of Password		0	0	9
Remark:		If all 4 digits of the Password are 0 (default setting) the Password request is skipped				

Device Information		
ID		
.105	ID: xxxxxx	xxxxx = Device ID
	SW: aa.dd.ccb	dd: Software version of Display Software aa: Software version of Measuring Software cc: Index of Configuration set b: Version of Configuration set

10.51 C10-11:2019 LV-IP [ID 601] Interface Protection low voltage

Connection Mode			Conformity Range		Possible Range	
ID		Default				
.003	Connection	4-wire (LN)	4-wire (LN)		2-wire, 3-wire, 4-wire (LN), 4-wire (LN+LL)	

Nominal Voltage				Conformity Range		Possible Range	
ID		Default		Min	Max	Min	Max
.005	ULN/LL nom	Unom Y	V	230.0	230.0	100.0	240.0
		Unom Δ	V	400.0	400.0	173.9	417.4

Functional Safety			Conformity Range		Possible Range	
ID		Default				
.007	Errtol	Fixed to 1ch				
Remark:		1ch means: 1 channel without functional safety and 1 auxilliary contact1 necessary				

Overvoltage1 Line to Neutral				Conformity Range		Possible Range	
ID		Default		Min	Max	Min	Max
.019	U LN > off	U _{THR} OFF	%Unom	110	100	100	135
.020	U LN > on	U _{THR} ON	%Unom	109	100	100	135
.021	T U LN >	Time OFF	ms	1000	0	0	10000
Comment:		U LN > off has a fixed offset of 0.25% U _{NOM} subtracted from the displayed value					
Only active for:		Connection Modes: 2-wire, 4-wire (LN), 4-wire (LN+LL)					

Undervoltage1 Line to Neutral				Conformity Range		Possible Range	
ID		Default		Min	Max	Min	Max
.023	U LN < off	U _{THR} OFF	%Unom	70	50	0	100
.024	U LN < on	U _{THR} ON	%Unom	85	50	0	100
.025	T U LN <	Time OFF	ms	1500	0	0	10000
Comment:		U LN < off has a fixed offset of 0.25% U _{NOM} added to the displayed value					
Only active for:		Connection Modes: 2-wire, 4-wire (LN), 4-wire (LN+LL)					

Overvoltage2 Line to Neutral				Conformity Range		Possible Range	
ID		Default		Min	Max	Min	Max
.035	U LN>> off	U _{THR} OFF	%Unom	115	100	100	135
.036	U LN>> on	U _{THR} ON	%Unom	114	100	100	135
		Time OFF	ms	Fixed to fastest possible disconnection			
Comment:		U LN > off has a fixed offset of 0.25% U _{NOM} subtracted from the displayed value					
Only active for:		Connection Modes: 2-wire, 4-wire (LN), 4-wire (LN+LL)					

Undervoltage2 Line to Neutral				Conformity Range		Possible Range	
ID		Default		Min	Max	Min	Max
.039	U LN<< off	U _{THR} OFF	%Unom	25	25	0	100
.040	U LN<< on	U _{THR} ON	%Unom	85	50	0	100
		Time OFF	ms	Fixed to fastest possible disconnection			
Comment:		U LN < off has a fixed offset of 0.25% U _{NOM} added to the displayed value					
Only active for:		Connection Modes: 2-wire, 4-wire (LN), 4-wire (LN+LL)					

Overfrequency1				Conformity Range		Possible Range	
ID		Default		Min	Max	Min	Max
.055	f > off	f _{THR} OFF	Hz	51.50	51.50	50.00	55.00
.056	f > on	f _{THR} ON	Hz	50.10	50.00	50.00	55.00
		Time OFF	ms	Fixed to fastest possible disconnection			
Comment:		f > off has a fixed offset of 0.01 Hz subtracted to the displayed value					
Only active for:		Voltage > 20% U _{NOM}					

Underfrequency1				Conformity Range		Possible Range		
ID				Default	Min	Max	Min	Max
.059	f < off	f _{THR} OFF	Hz	47.50	47.50	47.50	40.00	50.00
.060	f < on	f _{THR} ON	Hz	49.90	47.00	50.00	40.00	50.00
		Time OFF	ms	Fixed to fastest possible disconnection				
Comment:		f < off has a fixed offset of 0.01 Hz added to the displayed value						
Only active for:		Voltage > 20% U _{NOM}						

Frequency measuring in general				Conformity Range		Possible Range		
ID				Default	Min	Max	Min	Max
.113	F wnd	Window length	ms	Fixed window length 100ms				

Rate of Change of Frequency (RoCoF)				Conformity Range		Possible Range		
ID				Default	Min	Max	Min	Max
.090	RoCoF	Enable Function		off	on / off		on / off	
.091	RoCoF off	RoCoF _{THR} OFF	mHz/s	1000	1000	1000	100	2000
.092	RoCoF on	RoCoF _{THR} ON	mHz/s	800	100	1000	100	1000
.093	RoCoF t	Time OFF	ms	0	0	0	0	1000
.111	RoCoF wnd	Window length	ms	Fixed window length 100ms				

Phase Shift (PShift)				Conformity Range		Possible Range		
ID				Default	Min	Max	Min	Max
.094	PShift	Enable Function		on	on / off		on / off	
.095	PShift off	PShift _{THR} OFF	°	7	7	7	3	15
.096	PShift on	PShift _{THR} ON	°	5	3	7	3	15
		Time OFF	ms	Fixed to the fastest possible disconnection				
.112	PShift wnd	Window length	ms	Fixed window length 100ms				
Comment:		PShift off has a fixed offset of 1° subtracted from the displayed value						

Auxiliary Contact type				Conformity Range		Possible Range		
ID				Default	Min	Max	Min	Max
.099	Contact	Type	dis. (disabled)		n.o. (normally opened) n.c. (normally closed) dis. (disabled)		n.o. (normally opened) n.c. (normally closed) dis. (disabled)	
.100	Contact t	Time OFF	ms	300	100	300	10	5000
.114	I3 STOP	Type	n.o. (normally opened)		n.o. (normally opened) n.c. (normally closed) dis. (disabled)		n.o. (normally opened) n.c. (normally closed) dis. (disabled)	

Turn-on delay				Conformity Range		Possible Range		
ID				Default	Min	Max	Min	Max
.102	Ton delay	Turn on time	s	60	60	60	0	600

Password				Default	Min	Max
ID						
.106	PW1	1 st digit of Password		0	0	9
.107	PW2	2 nd digit of Password		0	0	9
.108	PW3	3 rd digit of Password		0	0	9
.109	PW4	4 th digit of Password		0	0	9
Remark:		If all 4 digits of the Password are 0 (default setting) the Password request is skipped				

Device Information		
ID		
.105	ID: xxxxxx SW: aa.dd.ccb	xxxxx = Device ID dd: Software version of Display Software aa: Software version of Measuring Software cc: Index of Configuration set b: Version of Configuration set

10.52 C10-11:2019 HV-IP [ID 651] Interface Protection / High Voltage

Connection Mode			Conformity Range		Possible Range	
ID		Default				
.003	Connection	3-wire	3-wire		2-wire, 3-wire, 4-wire (LN), 4-wire (LN+LL)	

Nominal Voltage				Conformity Range		Possible Range	
ID		Default		Min	Max	Min	Max
.005	ULN/LL nom	Unom Y	V	230.0	57.5	230.0	28.8
		Unom Δ	V	400.0	100.0	400.0	50.0

Functional Safety			Conformity Range		Possible Range	
ID		Default				
.007	Errtol	Fixed to 1ch				
Remark:		1ch means: 1 channel without functional safety and 1 auxilliary contact1 necessary				

Overvoltage1 Line to Line				Conformity Range		Possible Range	
ID		Default		Min	Max	Min	Max
.011	U LL > off	U _{THR} OFF	%Unom	110	100	110	135
.012	U LL > on	U _{THR} ON	%Unom	109	100	120	135
.013	T U LL >	Time OFF	ms	1000	0	3000	10000
Comment:		U LL > off has a fixed offset of 0.25% U _{NOM} subtracted from the displayed value					
Only active for:		Connection Modes: 3-wire, 4-wire (LN+LL)					

Undervoltage1 Line to Line				Conformity Range		Possible Range	
ID		Default		Min	Max	Min	Max
.015	U LL < off	U _{THR} OFF	%Unom	70	50	85	100
.016	U LL < on	U _{THR} ON	%Unom	90	50	100	100
.017	T U LL <	Time OFF	ms	1500	0	1500	10000
Comment:		U LL < off has a fixed offset of 0.25% U _{NOM} added to the displayed value					
Only active for:		Connection Modes: 3-wire, 4-wire (LN+LL)					

Overvoltage2 Line to Line				Conformity Range		Possible Range	
ID		Default		Min	Max	Min	Max
.027	U LL>> off	U _{THR} OFF	%Unom	115	100	130	135
.028	U LL>> on	U _{THR} ON	%Unom	114	100	120	135
		Time OFF	ms	Fixed to fastest possible disconnection			
Comment:		U LL>> off has a fixed offset of 0.25% U _{NOM} subtracted from the displayed value					
Only active for:		Connection Modes: 3-wire, 4-wire (LN+LL)					

Undervoltage2 Line to Line				Conformity Range		Possible Range	
ID		Default		Min	Max	Min	Max
.031	U LL<< off	U _{THR} OFF	%Unom	25	25	50	100
.032	U LL<< on	U _{THR} ON	%Unom	90	50	100	100
		Time OFF	ms	Fixed to fastest possible disconnection			
Comment:		U LL<< off has a fixed offset of 0.25% U _{NOM} added to the displayed value					
Only active for:		Connection Modes: 3-wire, 4-wire (LN+LL)					

Overfrequency1				Conformity Range		Possible Range	
ID		Default		Min	Max	Min	Max
.055	f > off	f _{THR} OFF	Hz	51.50	51.50	50.00	55.00
.056	f > on	f _{THR} ON	Hz	50.10	50.00	52.00	55.00
		Time OFF	ms	Fixed to fastest possible disconnection			
Comment:		f > off has a fixed offset of 0.01 Hz subtracted to the displayed value					
Only active for:		Voltage > 20% U _{NOM}					

Underfrequency1				Conformity Range		Possible Range		
ID				Default	Min	Max	Min	Max
.059	f < off	f _{THR} OFF	Hz	47.50	47.50	47.50	40.00	50.00
.060	f < on	f _{THR} ON	Hz	49.90	47.00	50.00	40.00	50.00
		Time OFF	ms	Fixed to fastest possible disconnection				
Comment:		f < off has a fixed offset of 0.01 Hz added to the displayed value						
Only active for:		Voltage > 20% U _{NOM}						

Frequency measuring in general				Conformity Range		Possible Range		
ID				Default	Min	Max	Min	Max
.113	F wnd	Window length	ms	Fixed window length 100ms				

Rate of Change of Frequency (RoCoF)				Conformity Range		Possible Range		
ID				Default	Min	Max	Min	Max
.090	RoCoF	Enable Function		off	on / off		on / off	
.091	RoCoF off	RoCoF _{THR} OFF	mHz/s	1000	1000	1000	100	2000
.092	RoCoF on	RoCoF _{THR} ON	mHz/s	800	100	1000	100	1000
.093	RoCoF t	Time OFF	ms	0	0	0	0	1000
.111	RoCoF wnd	Window length	ms	Fixed window length 100ms				

Phase Shift (PShift)				Conformity Range		Possible Range		
ID				Default	Min	Max	Min	Max
.094	PShift	Enable Function		on	on / off		on / off	
.095	PShift off	PShift _{THR} OFF	°	7	7	7	3	15
.096	PShift on	PShift _{THR} ON	°	5	3	7	3	15
		Time OFF	ms	Fixed to the fastest possible disconnection				
.112	PShift wnd	Window length	ms	Fixed window length 100ms				
Comment:		PShift off has a fixed offset of 1° subtracted from the displayed value						

Auxiliary Contact type				Conformity Range		Possible Range		
ID				Default	Min	Max	Min	Max
.099	Contact	Type	dis. (disabled)		n.o. (normally opened) n.c. (normally closed) dis. (disabled)		n.o. (normally opened) n.c. (normally closed) dis. (disabled)	
.100	Contact t	Time OFF	ms	300	100	300	10	5000
.114	I3 STOP	Type	n.o. (normally opened)		n.o. (normally opened) n.c. (normally closed) dis. (disabled)		n.o. (normally opened) n.c. (normally closed) dis. (disabled)	

Turn-on delay				Conformity Range		Possible Range		
ID				Default	Min	Max	Min	Max
.102	Ton delay	Turn on time	s	60	60	60	0	600

Password				Default	Min	Max
ID						
.106	PW1	1 st digit of Password		0	0	9
.107	PW2	2 nd digit of Password		0	0	9
.108	PW3	3 rd digit of Password		0	0	9
.109	PW4	4 th digit of Password		0	0	9
Remark:		If all 4 digits of the Password are 0 (default setting) the Password request is skipped				

Device Information		
ID		
.105	ID: xxxxxx SW: aa.dd.ccb	xxxxx = Device ID dd: Software version of Display Software aa: Software version of Measuring Software cc: Index of Configuration set b: Version of Configuration set

Für weitere Informationen kontaktieren Sie bitte:

TELE Haase Steuergeräte Ges.m.b.H.
Vorarlberger Allee 38
1230 Wien
Österreich

TELEFON		+43 / 1 614 74 - 0
ONLINE SUPPORT		support@tele-haase.at
WEB		www.tele-online.com